

**Z**

**VEHICLE IDENTIFICATION NUMBER (VIN)  
(CHASSIS NUMBER)**

**JM1 NB353\* Y# 100001—**

**2002 Miata Factory Wiring Diagram**

**WIRING COLOR CODE**

<b>Color</b>	<b>Code</b>	<b>Color</b>	<b>Code</b>
Blue	L	Orange	O
Black	B	Pink	P
Brown	BR	Red	R
Dark Blue	DL	Purple	PU
Dark Green	DG	Sky Blue	SB
Green	G	Tan	T
Gray	GY	White	W
Light Blue	LB	Yellow	Y
Light Green	LG	Violet	V
Natural	N		

## Ground points

- This shows ground points of the harness.

### GROUND POINTS(4SD)

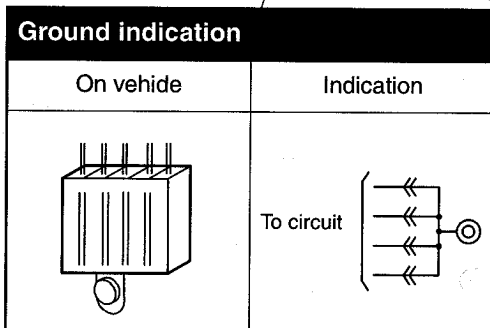
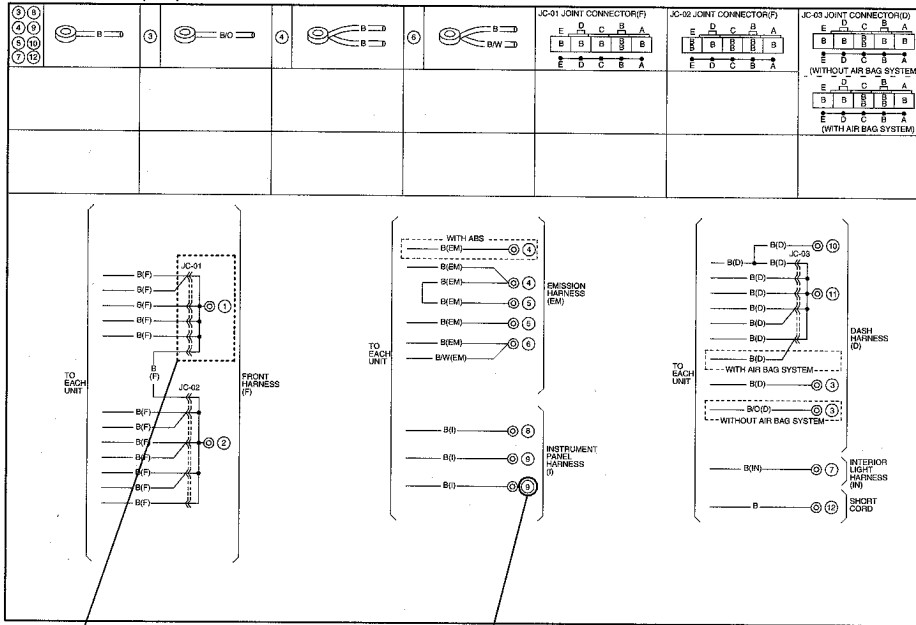

**On circuit diagrams and ground points**  
 The ground connection numbers in system circuit diagrams correspond to those in the ground point diagram.

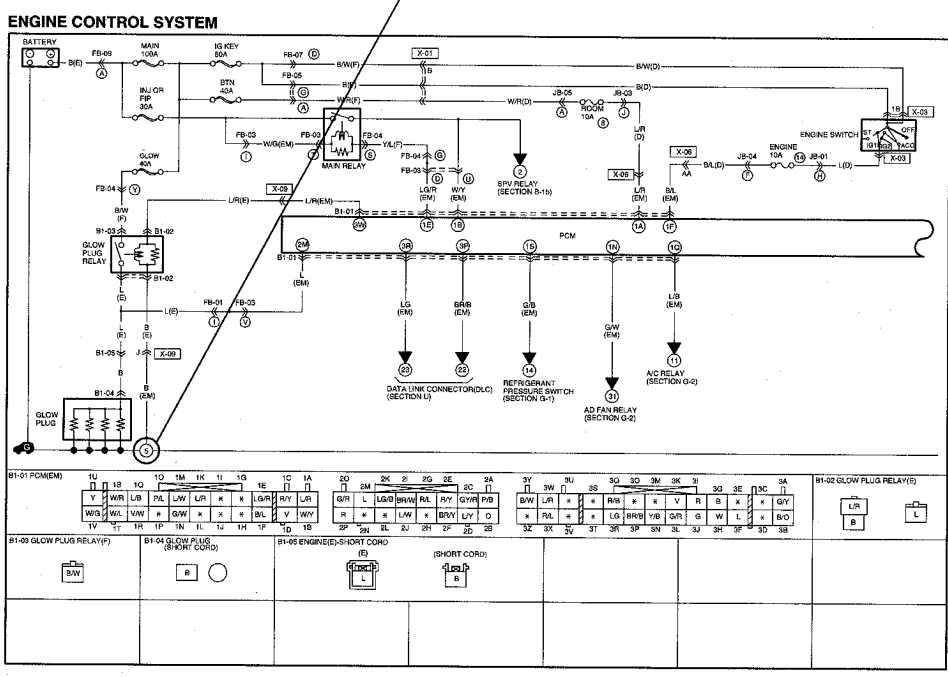

## System circuit diagram/connector diagram

- These diagrams show the circuits for each system, from the power supply to the ground. The power supply side is on the upper part of the page, the ground side on the lower part. The diagrams describe circuits with the ignition switch off.

Below is an explanation of the various points in the diagram.

**System name**

### ENGINE CONTROL SYSTEM

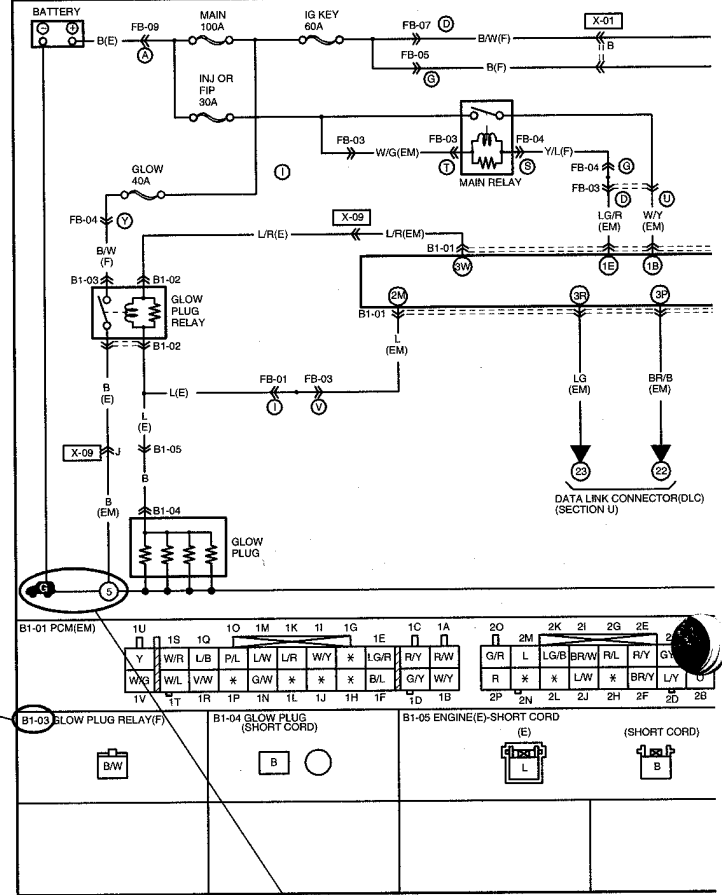

### Connector code

The prefix letter indicates the system in which the connector is used.

- Y : Ground connector
- A : Charging system/starting system connectors
- B : Engine control system connectors
- C : Gauge control system connectors
- D : Wiper system connectors
- E : Lighting system connectors
- F : Signal system connectors
- G : Air-conditioning system connectors
- H : Key interlock/Shift-lock system connectors
- I : Interior light system connectors
- J : Audio/radio connectors
- K : Power window/power door lock system connectors
- L : Remote control mirror system connectors
- O : Anti-lock brake system connectors
- Q : Auto cruise control system connectors
- S : Passive shoulder belt control/Airbag system connectors
- U : Data link connector
- X : Common connectors

### Ground numbers

A harness ground is represented differently than a unit ground.

Types of grounds	Symbol
<p><b>Harness</b></p>	
<p><b>Unit</b></p>	

**System code**

The number indicates that the circuit continues to the related system diagram.

**B-1a**

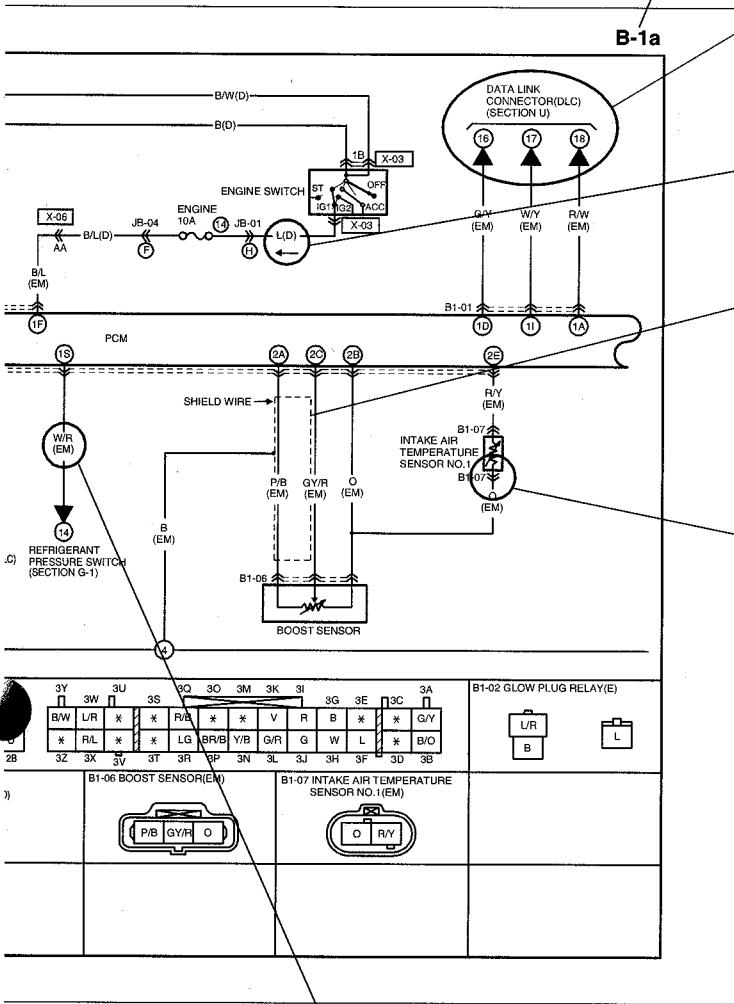

**Current symbol**  
Current flows in the direction of the arrow.

**Indicates shielded wire.\***

\*Shielded wire :  
Prevents signal disturbances from electrical interference.  
Wire is covered by a metal meshing for grounding.

### Connector symbols

• Male and female connectors are represented as follows in the circuit and connector diagrams.

		Circuit diagram symbol	Connector diagram symbol
Male			
Female			

• Like connectors are linked by dashed lines between the connector symbols.  
• Connector diagrams show connectors on the harness side. The terminal indicates the view from the harness side.

(Example)

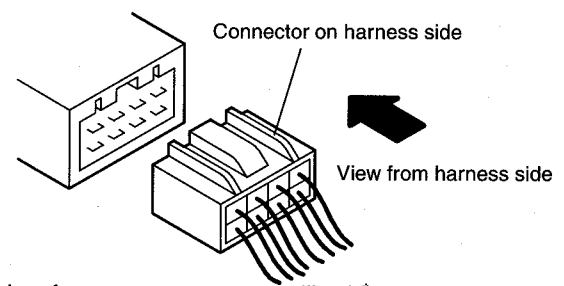

• Colors for connectors except milk-white are given in locations.  
• Unused terminals are indicated by \*.

### Wire color code (harness symbol)

• Two-color wires are indicated by a two-letter symbol. The first indicates the base color of the wire, the second the color of the stripe.  
For example:

W/R is a white wire with a red strip  
BR/Y is a brown wire with a yellow strip

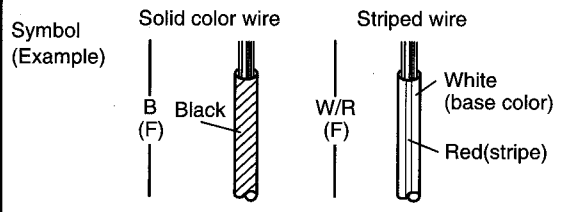

• The harness symbol is in ( ) following the harness symbols (refer to P-7.).

## Routing diagram



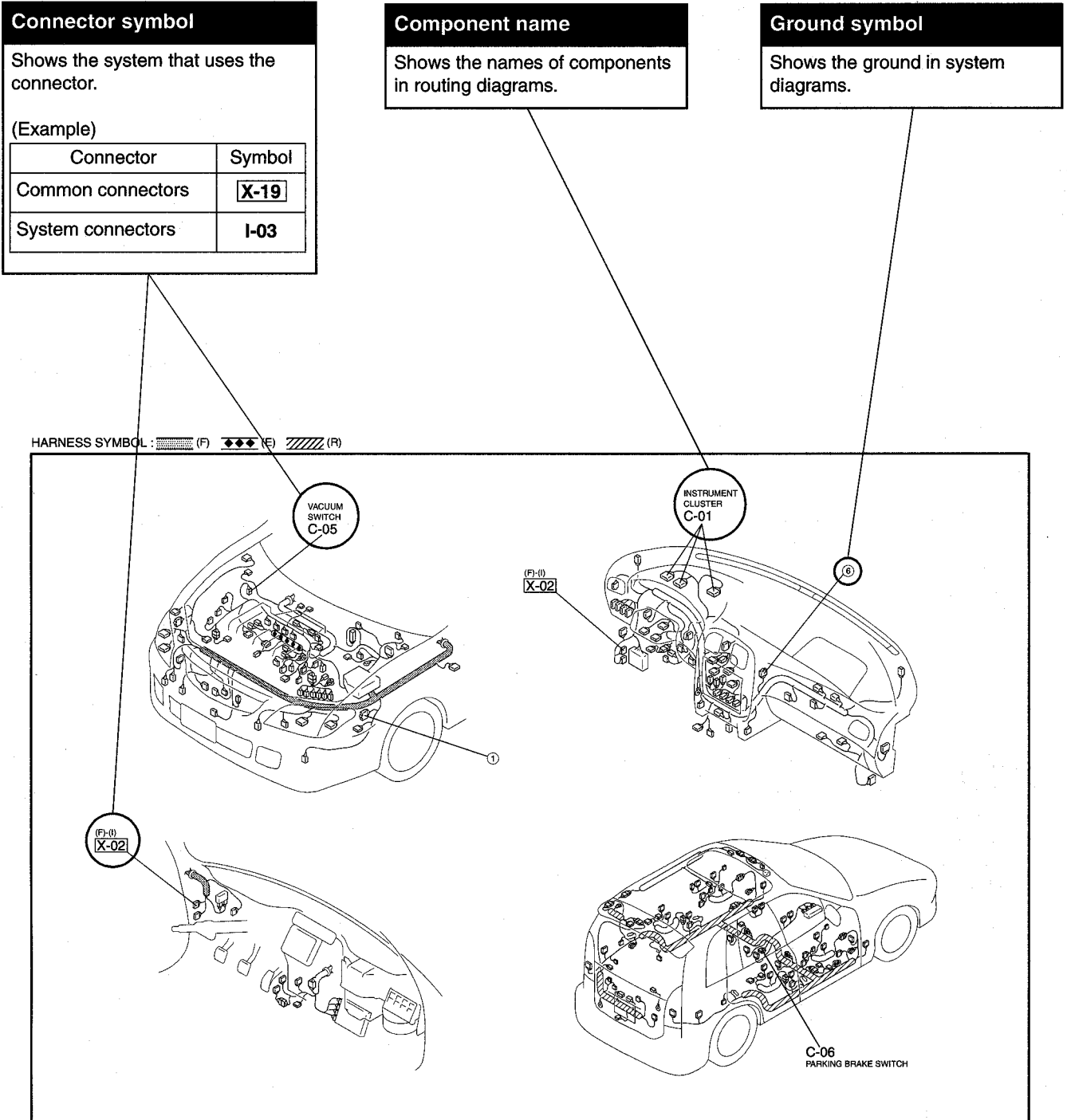







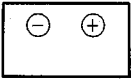

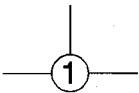

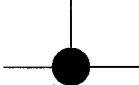

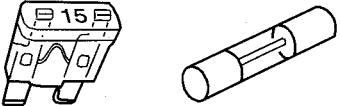
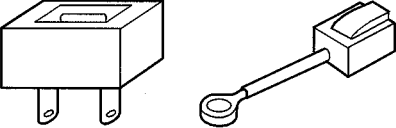
- The routing diagram shows where electrical components are on the system circuit diagram by call out line and connector symbols.







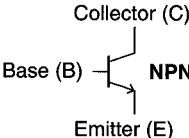
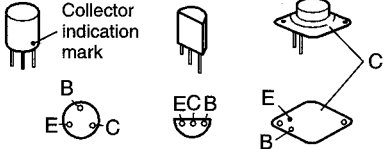

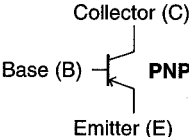
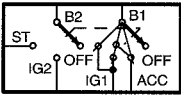

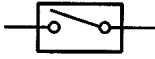

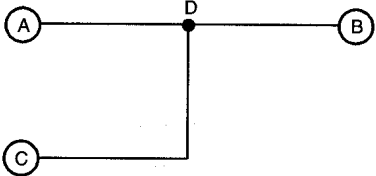
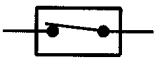

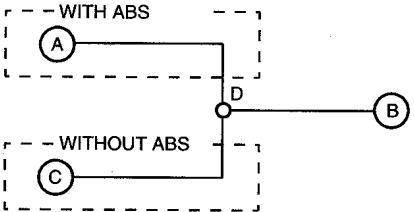
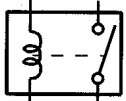
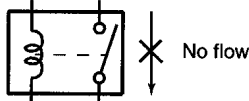
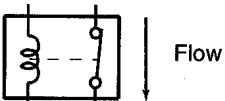
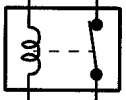
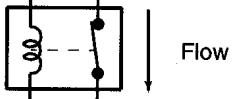
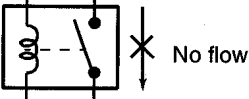
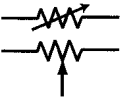
## Harness symbols

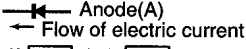
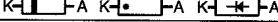
DESCRIPTION OF HARNESS	SYMBOL	DESCRIPTION OF HARNESS	SYMBOL
FRONT HARNESS	(F)	DOOR NO.1 HARNESS	(DR1)
FRONT NO.2 HARNESS	(F2)	DOOR NO.2 HARNESS	(DR2)
ENGINE HARNESS	(E)	DOOR NO.3 HARNESS	(DR3)
DASH HARNESS	(D)	DOOR NO.4 HARNESS	(DR4)
REAR HARNESS	(R)	FLOOR HARNESS	(FR)
REAR NO.2 HARNESS	(R2)	INTERIOR LIGHT HARNESS	(IN)
REAR NO.3 HARNESS	(R3)	A/C HARNESS	(AC)
INSTRUMENT PANEL HARNESS	( I )		
EMISSION HARNESS	(EM)		
EMISSION NO.2 HARNESS	(EM2)		
EMISSION NO.3 HARNESS	(EM3)		

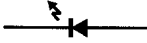
## Symbols

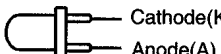
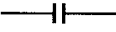
Symbol	Meaning	Symbol	Meaning	
<p>Battery</p> 	<ul style="list-style-type: none"> <li>Generates electricity through chemical reaction.</li> <li>Supplies direct current to circuits.</li> </ul>	<p>Light</p> 	<ul style="list-style-type: none"> <li>Emits light and generates heat when current flows through filament.</li> </ul>	
<p>Ground (1)</p> 	<ul style="list-style-type: none"> <li>Connecting point to vehicle body or other ground wire where current flows from positive to negative terminal of battery.</li> <li>Ground (1) indicates a ground point to body through wire harness.</li> <li>Ground (2) indicates point where component is grounded directly to body.</li> </ul>	<p>Resistance</p> 	<ul style="list-style-type: none"> <li>A resistor with a constant value.</li> <li>Mainly used to protect electrical components in circuits by maintaining rated voltage.</li> </ul>	
<p>Ground (2)</p> 		<p>Remarks</p> <ul style="list-style-type: none"> <li>Current will not flow through a circuit if ground is faulty.</li> </ul>		<p>Motor</p> 
<p>Fuse (1)</p> 	<p>Precautions</p> <ul style="list-style-type: none"> <li>Do not replace with fuses exceeding specified capacity.</li> </ul> <p>&lt;Blade type&gt;      &lt;Tube type&gt;</p>  <p>&lt;Cartridge type&gt;      &lt;Fusible link&gt;</p> 	<p>Pump</p> 	<ul style="list-style-type: none"> <li>Pulls in and discharges gases and liquids.</li> </ul>	
<p>(box)</p>		<p>Cigarette lighter</p> 		<ul style="list-style-type: none"> <li>Electrical coil that generates heat.</li> </ul>
<p>Fuse (2)</p> 		<p>Horn</p> 		
<p>(Cartridge)</p>		<p>Speaker</p> 		<ul style="list-style-type: none"> <li>Generates heat when current flows.</li> </ul>
<p>Main fuse/ Fusible link</p> 	<p>Heater</p> 	<ul style="list-style-type: none"> <li>Generates heat when current flows.</li> </ul>		
<p>Transistor (1)</p> 	<ul style="list-style-type: none"> <li>Electrical switching component.</li> <li>Turns on when voltage is applied to the base (B).</li> </ul> <p>Collector indication mark</p> 		<p>Speed sensor</p> 	<ul style="list-style-type: none"> <li>Movement of magnet in speedometer turns contact within sensor on and off.</li> </ul>
<p>Transistor (2)</p> 		<ul style="list-style-type: none"> <li>Reading code.</li> </ul> <p>2 S C 828 A      Revision mark</p> <p>Semiconductor      Number of terminals</p> <p>A: High-frequency PNP B: Low-frequency PNP C: High-frequency NPN D: Low-frequency NPN</p>	<p>Ignition switch</p> 	

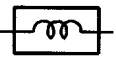
Symbol	Meaning	Symbol	Meaning
<p>Switch (1)</p>  <p>Normally open (NO)</p>	<ul style="list-style-type: none"> <li>Allows or breaks current flow by opening and closing circuits.</li> </ul>	<p>Harness Connection</p>  <p>When circuit C-D is connected to circuit A-B, the connection D is indicated by a black dot.</p>	 <p>For vehicles with ABS, use the A-B circuit.</p>
<p>Switch (2)</p>  <p>Normally closed (NC)</p>		<p>Selection</p>  <p>Diversion point D for the different circuits according to the vehicle's specification is indicated by a white dot.</p>	 <p>For vehicles without ABS, use the C-B circuit.</p>
<p>Relay (1)</p>  <p>Normally open (NO)</p>	<ul style="list-style-type: none"> <li>Current flowing through coil produces electromagnetic force causing contact to open or close.</li> </ul> <div style="display: flex; justify-content: space-around;"> <div style="text-align: center;"> <p>No current to coil</p>  <p>No flow</p> </div> <div style="text-align: center;"> <p>Current to coil</p>  <p>Flow</p> </div> </div>		
<p>Relay (2)</p>  <p>Normally closed (NC)</p>	<ul style="list-style-type: none"> <li>Current flowing through coil produces electromagnetic force causing contact to close.</li> </ul> <div style="display: flex; justify-content: space-around;"> <div style="text-align: center;"> <p>No current to coil</p>  <p>Flow</p> </div> <div style="text-align: center;"> <p>Current to coil</p>  <p>No flow</p> </div> </div>		
<p>Sensor (variable)</p> 	<ul style="list-style-type: none"> <li>Resistance changes with other components operation.</li> </ul>	<p>Diode</p> 	<ul style="list-style-type: none"> <li>Known as a semiconductor rectifier, the diode allows current flow in one direction only.</li> </ul> <p>Cathode(K)  Anode(A)</p> <p>← Flow of electric current</p> <p>K  A</p>
<p>Sensor (thermistor)</p> 	<ul style="list-style-type: none"> <li>Resistance changes with temperature.</li> </ul>	<p>Light-emitting diode (LED)</p> 	<ul style="list-style-type: none"> <li>A diode that lights when current flows.</li> <li>Unlike ordinary bulbs, the diode does not generate heat when lit.</li> </ul> <p>Cathode(K)  Anode(A)</p> <p> Anode(A)</p> <p>Flow of current</p>
<p>Capacitor</p> 	<ul style="list-style-type: none"> <li>Component that temporarily stores electrical charge.</li> </ul>	<p>Reference diode (Zener diode)</p> 	<ul style="list-style-type: none"> <li>Allows current to flow in one direction up to a certain voltage; allows current to flow in the other direction once that voltage is exceeded.</li> </ul>
<p>Solenoid</p> 	<ul style="list-style-type: none"> <li>Current flowing through coil generates electromagnetic force to operate plungers.</li> </ul>		



Symbol	Meaning
<p>Extent of the change in the wiring position (1)</p>	<ul style="list-style-type: none"> <li>The wiring position can be exchanged freely within the connector.</li> </ul>
<p>Extent of the change in the wiring position (2)</p>	<ul style="list-style-type: none"> <li>The wiring position can be exchanged according to the following combinations only. Between A and B, Between C and D, Between E and F</li> </ul>
<p>Extent of the change in the wiring position (3)</p>	<ul style="list-style-type: none"> <li>The wiring position can be exchanged according to the following combinations only. Between A, C and E, Between B, D and F</li> </ul>

### Abbreviations used in this booklet

3GR	Third Gear
4GR	Fourth Gear
A	Ampere
A/C	Air Conditioning
A/F	Air Fuel
A/R	Auto Reverse
AAS	Auto Adjusting Suspension
ABS	Anti-lock Braking System
ACC	Accessories
ACV	Air Control Valve
ADD	Additional
AIR	Secondary Air Injection
AIS	Air Injection System
ALL	Automatic Load Leveling
AM	Amplitude Modulation
AMP	Amplifier
ANT	Antenna
AP	Accelerator Pedal
AS	Autoshop
ASV	Air Supply Valve
AT	Automatic Transmission
ATX	Automatic Transaxle
B+	Battery Positive Voltage
BAC	Bypass Air Control
BARO	Barometric Pressure
CAC	Charge Air Cooler
CARB	Carburetor

CCT	Circuit
CIGAR	Cigarette
CIS	Continuous Fuel Injection System
CKP	Crankshaft Position Sensor
CLS	Closed Loop System
CMP	Camshaft Position Sensor
COMBI	Combination
CON	Conditioner
CONT	Control
CPU	Central Processing Unit
CSD	Cold Start Device
CTP	Closed Throttle Position
DEF	Defroster
DI	Distributor Ignition
DLC	Data Link Connector
DLI	Distributorless Ignition
DOHC	Double-Overhead Camshaft
DRL	Daytime Running light
DTC	Diagnostic Trouble Code(s)
DTM	Diagnostic Test Mode
ECPS	Electronically Controlled Power Steering
ECT	Engine Control Temperature
EGR	Exhaust Gas Recirculation
EI	Electronic Ignition
ELEC	Electric
ELR	Emergency Locking Retractor
ETR	Electronic Tuner



F	Front
F/I	Fuel Injector
FC	Fan Control
FICB	Fast-Idle Cam Breaker
FM	Frequency Modulation
FP	Fuel Pump
FPR	Fuel Pump Relay
GEN	Generator
GND	Ground
H/D	Heater/Defroster
HEAT	Heater
HEI	High-Energy Ignition
HI	High
HO2S	Heated Oxygen Sensor
IAC	Idle Air Control
IAT	Intake Air Temperature
ICM	Ignition Control Module
IG	Ignition
ILLUMI	Illumination
INT	Intermittent
JB	Joint Box
KS	Knock Sensor
LCD	Liquid Crystal Display
LF	Left Front
LH	Left Hand
LO	Low
LR	Left Rear
M	Motor
MAF	Mass Air Flow
MAP	Manifold Absolute Pressure
MFI	Multipoint Fuel Injection
MID	Middle
MIL	Malfunction Indicator Lamp
MIN	Minute
MIX	Mixture
MPX	Multiplex
MT	Manual Transmission
MTR	Mechanical Tuning Radio
MTX	Manual Transaxle
N	Neutral
NC	Normally Closed
NO	Normally Open
O2S	Oxygen Sensor
OBD	On-board Diagnostic
O/D	Over Drive
OFF	Switch Off

ON	Switch On
P	Power
P/S	Power Steering
PAIR	Pulsed Secondary Air Injection
PCM	Powertrain Control Module
PNP	Park/Neutral Position
PRCV	Pressure Regulator Control Solenoid Valve
PRG	Purge Solenoid Valve
PSP	Power Steering Pressure
PTC	Positive Temperature Coefficient Heater
QSS	Quick-Start System
R	Rear
REC	Recirculation
RF	Right Front
RH	Right Hand
RPM	Engine Speed
RR	Right Rear
SAS	Sophisticated Air Bag Sensor
SFI	Sequential Multipoint Fuel Injection
SOL	Solenoid
SPV	Spill Valve
ST	Start
SW	Switch
TC	Turbocharger
TCM	Transmission(Transaxle)Control Module
TCS	Tranction control system
TCV	Twin Scroll Turbocharger Solenoid Valve
TEMP	Temperature
TFT	Transaxle Fluid Temperature
TNS	Tail Number Side Lights
TICS	Triple Induction Control System
TP	Throttle Position Sensor
TR	Transmission Range
TR	Transmission(Transaxle)Range
TWS	Total Wiring System
V	Volt
VAF	Volume Air Flow Sensor
VENT	Ventilation
VOL	Volume
VR	Voltage Regulator
VRIS	Variable Resonance Induction System
VSS	Vehicle Speed Sensor
W	Watt(s)
WOT	Wide Open Throttle

# Ground Points

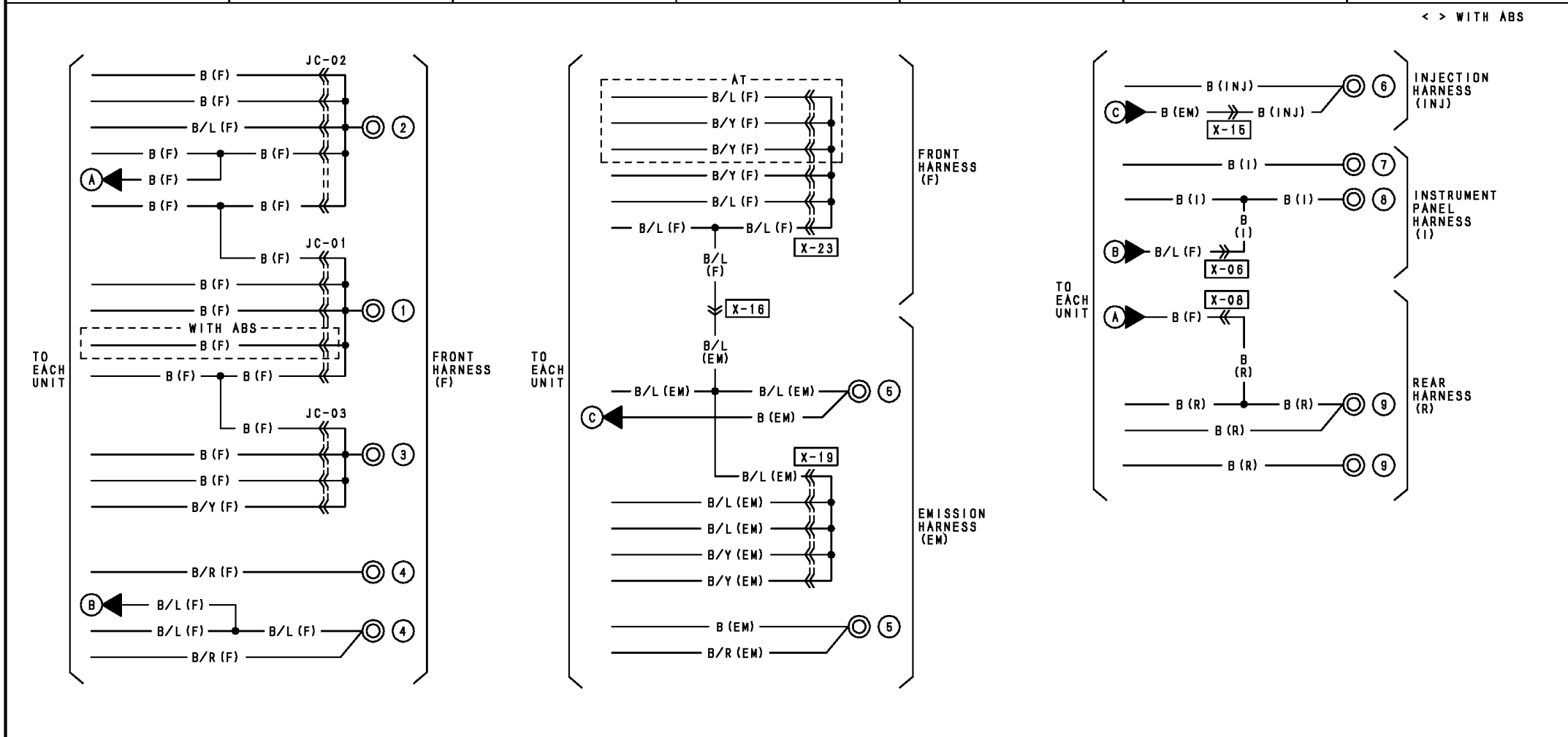
JC-01 JOINT CONNECTOR (F)	JC-02 JOINT CONNECTOR (F)	JC-03 JOINT CONNECTOR (F)				



HARNES SYMBOL :  (F)  (E)  (R)

# Ground Points

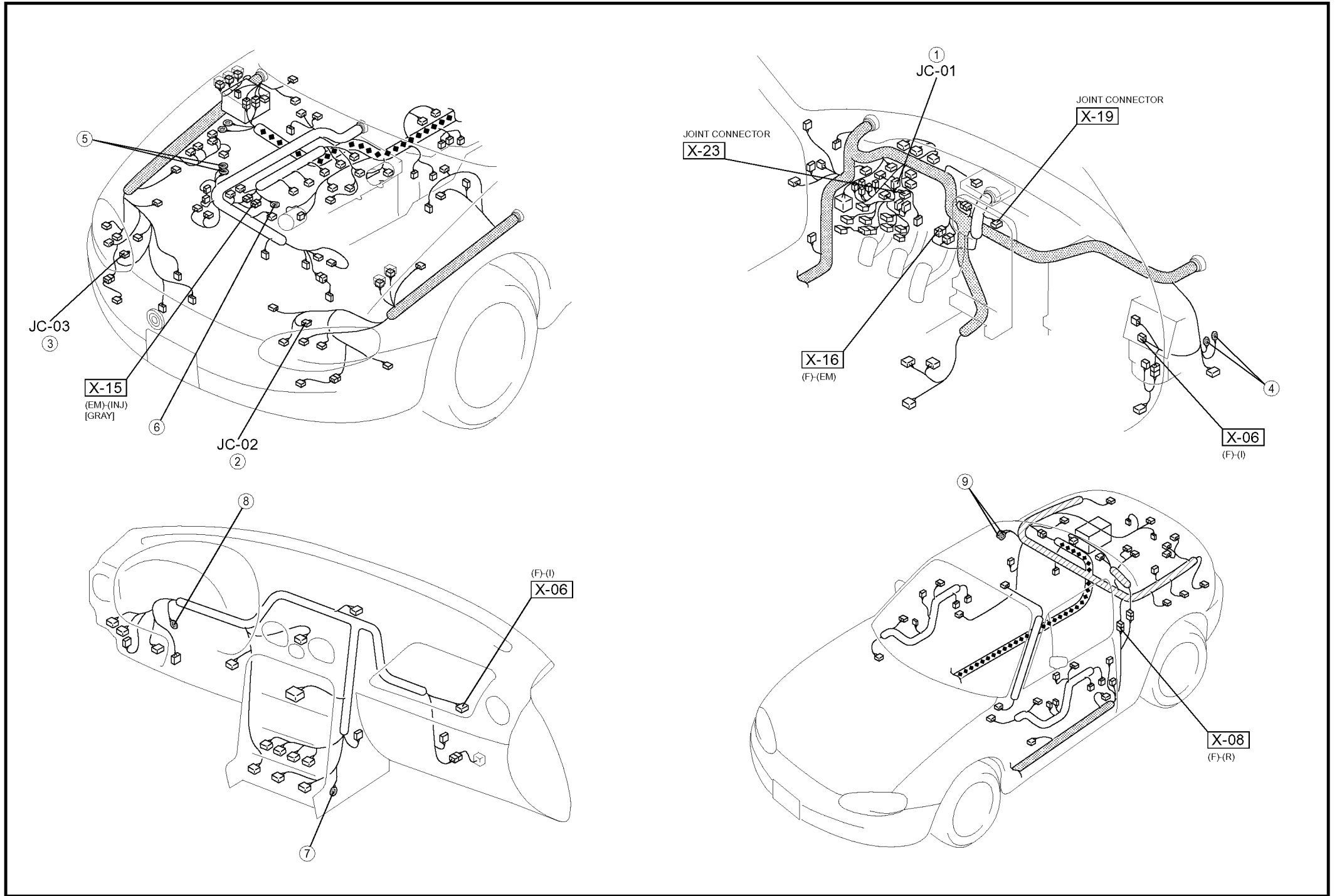

# Electrical Wiring Schematic | W-1

——— CURRENT FROM BATTERY  
 - - - - - CURRENT FROM IG1 TERMINAL OF IGNITION SWITCH  
 - - - - - CURRENT FROM IG2 TERMINAL OF IGNITION SWITCH  
 - - - - - CURRENT FROM ACC TERMINAL OF IGNITION SWITCH  
 ——— OTHER

SECTION	SYSTEM CIRCUIT
---------	----------------

SECTION	SYSTEM CIRCUIT
---------	----------------

B-2	FUEL CONTROL SYSTEM
F-1	TURN AND HAZARD WARNING LIGHT
K-2	POWER DOOR LOCK SYSTEM
I-4	TRUNK LID OPENER
0	ANTILOCK BRAKE SYSTEM
G	CONDENSER FAN SYSTEM / HEATER AND AIR CONDITIONER
U	DATA LINK CONNECTOR
A	CHARGING SYSTEM
Q	CRUISE CONTROL SYSTEM
I-3	INTERIOR LIGHT
F-2	BACK-UP LIGHT
I-2	REAR WINDOW DEFROSTER
D	WINDSHIELD WIPER AND WASHER
B-1a B-1b B-1c B-1d	ENGINE CONTROL SYSTEM
B-3	COOLING FAN SYSTEM

E-1 E-2	HEADLIGHT
E-4	FRONT FOG LIGHT
F-2	BRAKE LIGHT / HIGH-MOUNT BRAKE LIGHT / HORN
S-1	AIR BAG SYSTEM
E-3	FRONT SIDE MARKER LIGHT / LICENSE PLATE LIGHT / TRUNK COMPARTMENT LIGHT / PARKING LIGHT / TAILLIGHT
I-1	ILLUMINATION LIGHT
I-4	KEYLESS ENTRY SYSTEM
C-a C-b C-c	INSTRUMENT CLUSTER
H-1	EC-AT CONTROL SYSTEM
H-2	KEY INTERLOCK SYSTEM / SHIFT-LOCK SYSTEM
I-2	CIGARETTE LIGHTER
L	POWER OUTSIDE MIRROR
K-1	POWER WINDOW SYSTEM
J-3	POWER ANTENNA
T	IMMOBILIZER SYSTEM
J-1 J-2	AUDIO SYSTEM

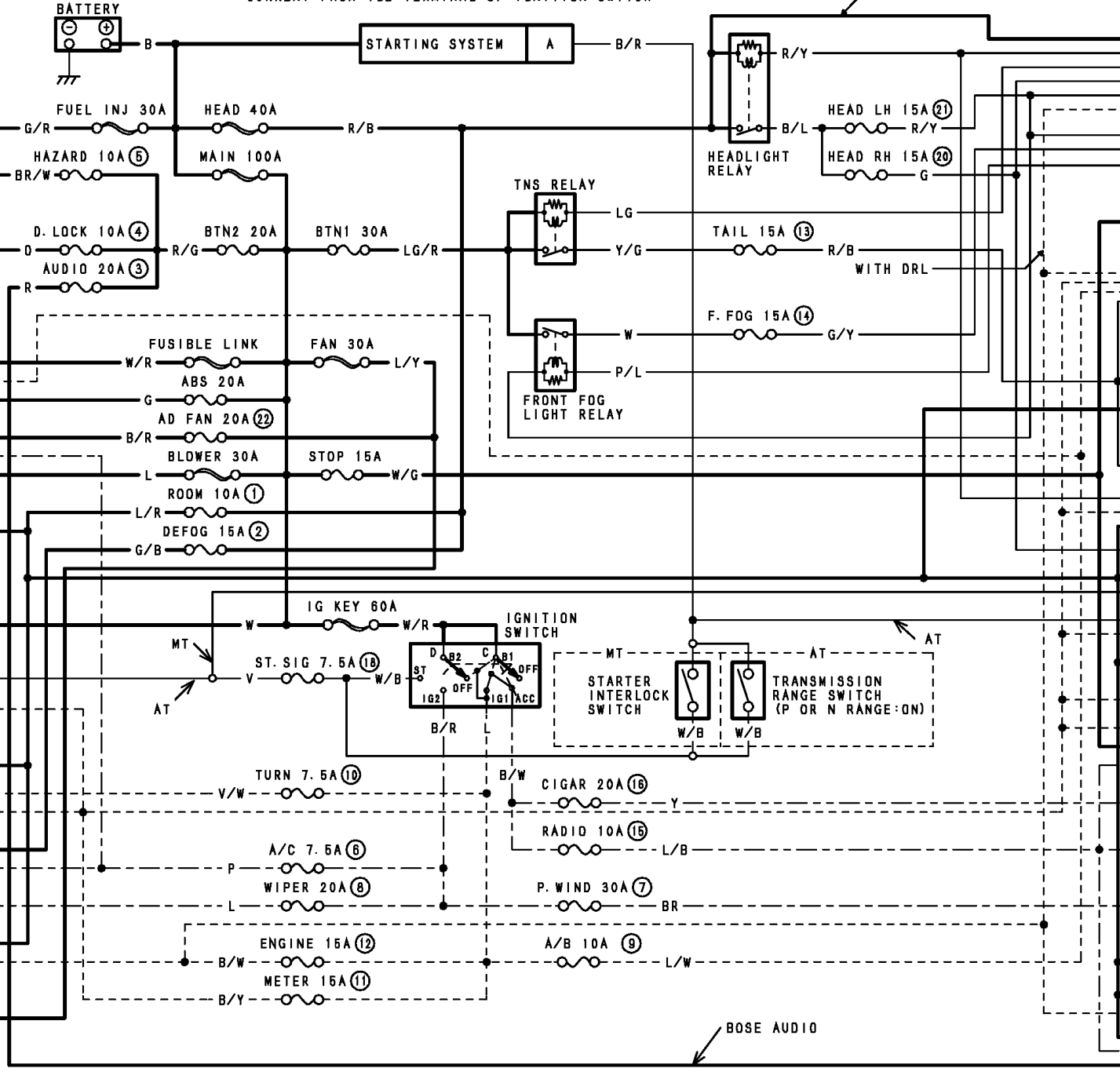

BOSE AUDIO

# Charging System \ Starting System \ A

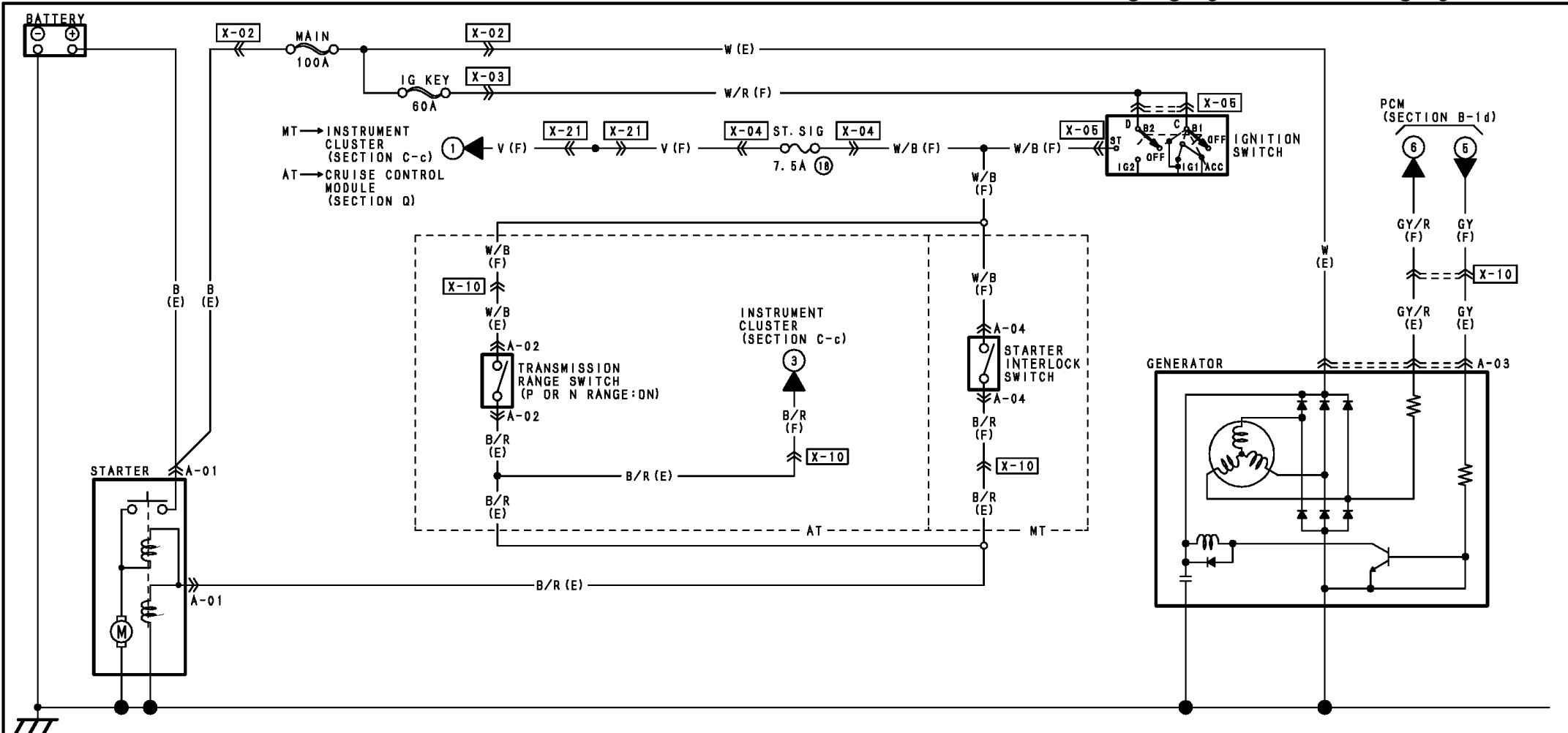

<p><b>A-01 STARTER (E)</b></p>	<p><b>A-02 TRANSMISSION RANGE SWITCH (E)</b></p> <p>(AT)</p>	<p><b>A-03 GENERATOR (E)</b></p>	<p><b>A-04 STARTER INTERLOCK SWITCH (F)</b></p>

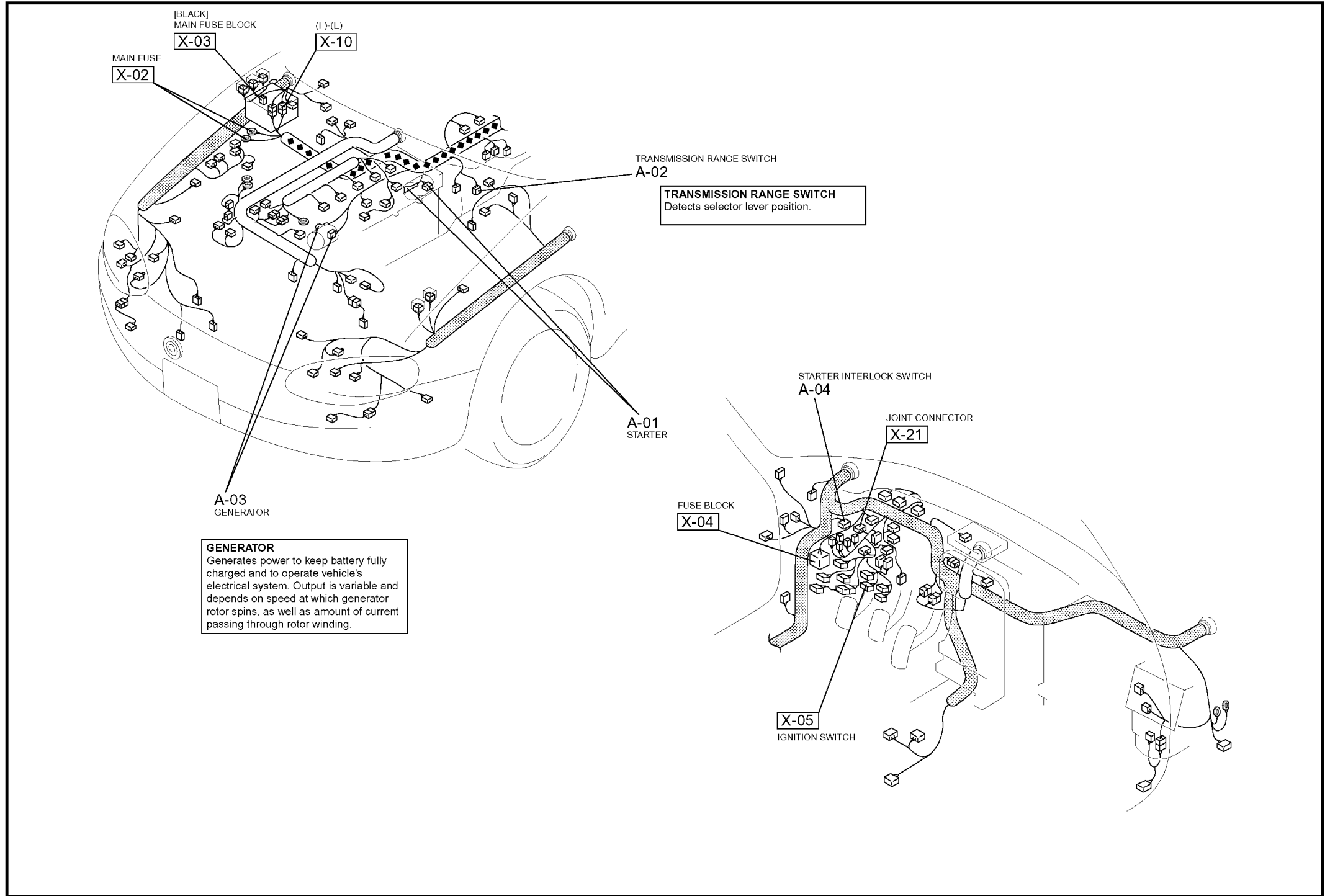

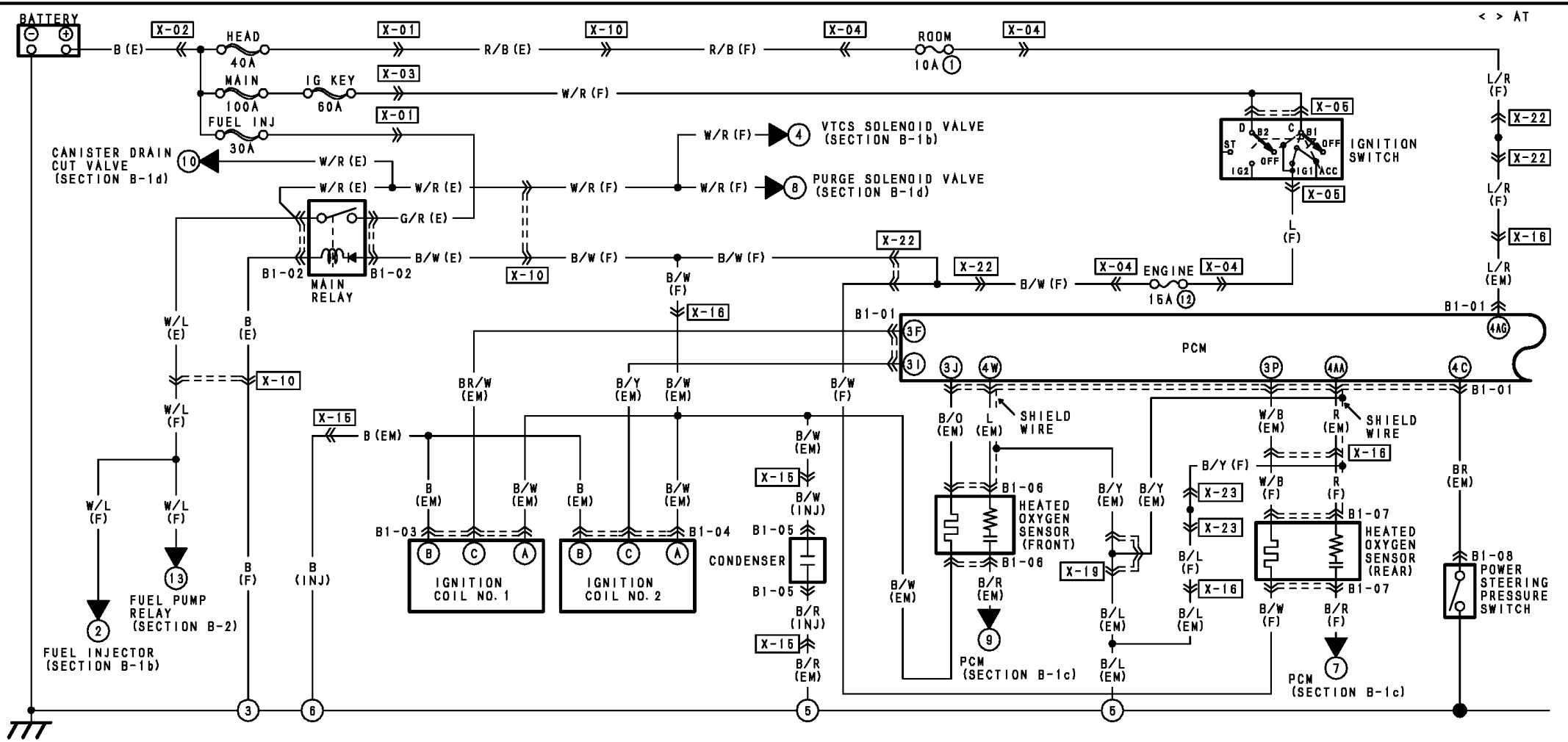

<p><b>B1-01 PCM (EM)</b></p> <table border="1"> <tr><td>3X *</td><td>3U BR/R</td><td>3P W/B</td><td>3W GY/R</td><td>3J B/D</td><td>3D GY/B</td><td>3A B</td></tr> <tr><td>3V W/W</td><td>3V GY/L</td><td>3S R/B</td><td>3D G/W</td><td>3M *</td><td>3K *</td><td>3H *</td></tr> <tr><td>3Z *</td><td>3W *</td><td>3T G/R</td><td>3D G/D</td><td>3L *</td><td>3I B/Y</td><td>3F BR/W</td></tr> <tr><td></td><td></td><td></td><td></td><td></td><td>3C G/Y</td><td></td></tr> </table> <table border="1"> <tr><td>4AF W/R</td><td>4AC V/G</td><td>4Z P/B</td><td>4U *</td><td>4R V/Y</td><td>4O B/R</td><td>4L LG/R</td><td>4D Y</td><td>4A B/L</td></tr> <tr><td>4AG L/R</td><td>4AD BR/B</td><td>4AA R</td><td>4X P</td><td>4V G/B</td><td>4S *</td><td>4P R/L</td><td>4W W</td><td>4J O</td></tr> <tr><td>4AH *</td><td>4AE L/Y</td><td>4AB R/G</td><td>4W L</td><td>4T GY</td><td>4N P/L</td><td>4K *</td><td>4I W/G</td><td>4F LG/B</td></tr> <tr><td></td><td></td><td></td><td></td><td></td><td>4C BR</td><td></td><td></td><td></td></tr> </table>	3X *	3U BR/R	3P W/B	3W GY/R	3J B/D	3D GY/B	3A B	3V W/W	3V GY/L	3S R/B	3D G/W	3M *	3K *	3H *	3Z *	3W *	3T G/R	3D G/D	3L *	3I B/Y	3F BR/W						3C G/Y		4AF W/R	4AC V/G	4Z P/B	4U *	4R V/Y	4O B/R	4L LG/R	4D Y	4A B/L	4AG L/R	4AD BR/B	4AA R	4X P	4V G/B	4S *	4P R/L	4W W	4J O	4AH *	4AE L/Y	4AB R/G	4W L	4T GY	4N P/L	4K *	4I W/G	4F LG/B						4C BR				<p><b>B1-02 MAIN RELAY (E)</b></p> <p>FRONT SIDE</p>	<p><b>B1-03 IGNITION COIL NO. 1 (EM)</b></p>	<p><b>B1-04 IGNITION COIL NO. 2 (EM)</b></p>	<p><b>B1-05 CONDENSER (INJ)</b></p>
3X *	3U BR/R	3P W/B	3W GY/R	3J B/D	3D GY/B	3A B																																																														
3V W/W	3V GY/L	3S R/B	3D G/W	3M *	3K *	3H *																																																														
3Z *	3W *	3T G/R	3D G/D	3L *	3I B/Y	3F BR/W																																																														
					3C G/Y																																																															
4AF W/R	4AC V/G	4Z P/B	4U *	4R V/Y	4O B/R	4L LG/R	4D Y	4A B/L																																																												
4AG L/R	4AD BR/B	4AA R	4X P	4V G/B	4S *	4P R/L	4W W	4J O																																																												
4AH *	4AE L/Y	4AB R/G	4W L	4T GY	4N P/L	4K *	4I W/G	4F LG/B																																																												
					4C BR																																																															
	<p>NOTE: THIS IS THE CONNECTOR AS SEEN FROM THE TERMINAL SIDE.</p>	<p><b>B1-06 HEATED OXYGEN SENSOR (FRONT) (EM)</b></p>	<p><b>B1-07 HEATED OXYGEN SENSOR (REAR) (F)</b></p>	<p><b>B1-08 POWER STEERING PRESSURE SWITCH (EM)</b></p>																																																																



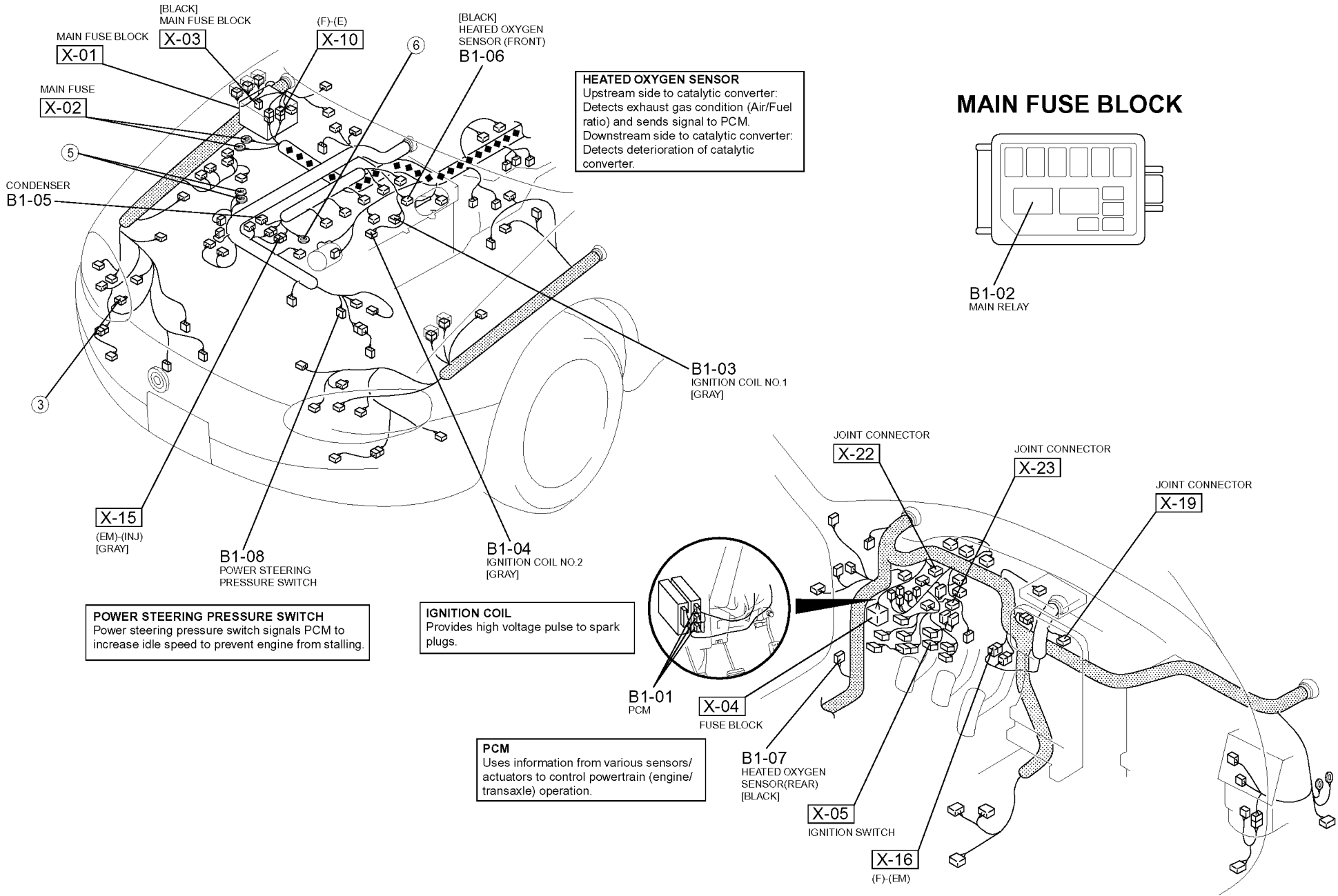

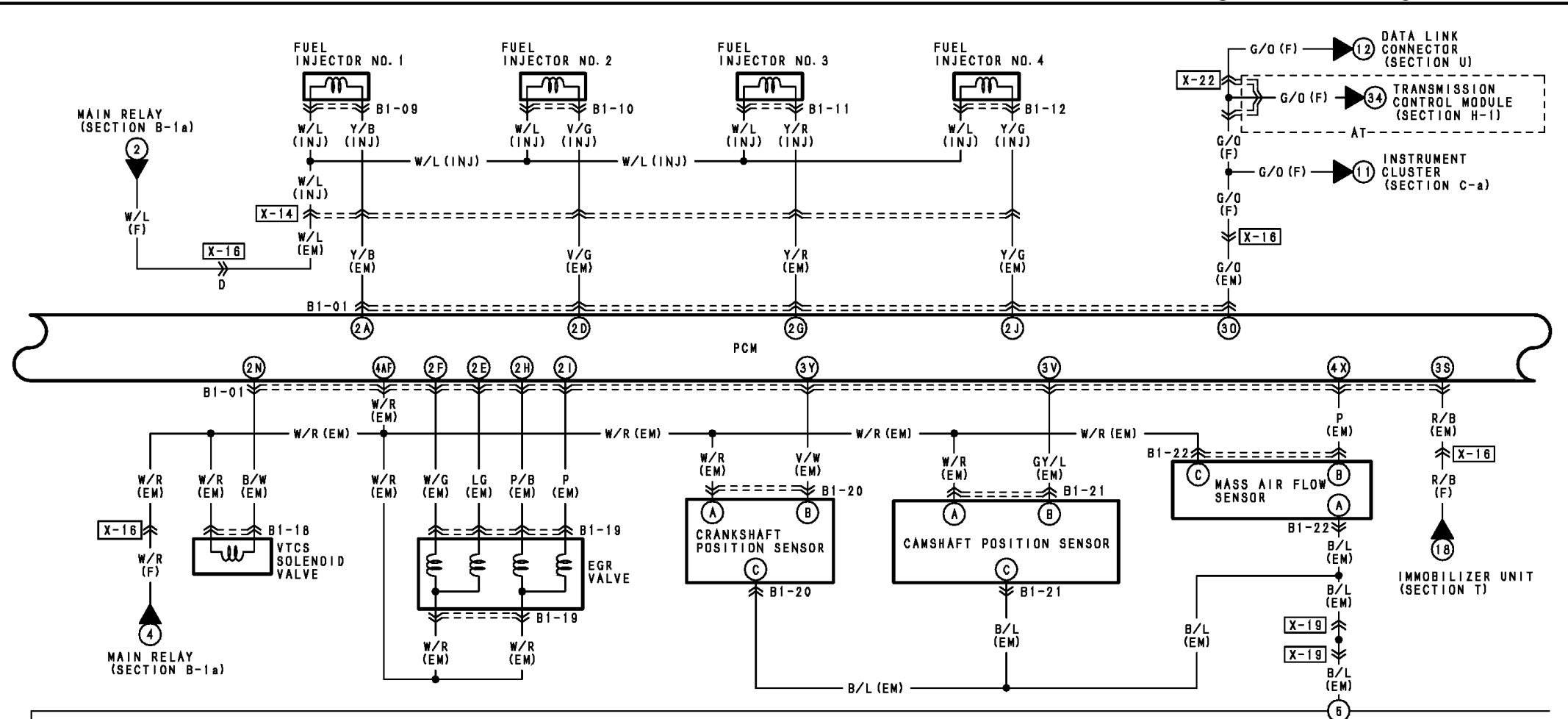

<p><b>B1-01 PCM (EM)</b></p> <table border="1"> <tr><td>2P</td><td>2W</td><td>2J</td><td>2G</td><td>2D</td><td>2A</td></tr> <tr><td>D</td><td>R/W</td><td>Y/G</td><td>Y/R</td><td>V/G</td><td>Y/B</td></tr> <tr><td>2Q</td><td>2N</td><td>2K</td><td>2H</td><td>2E</td><td>2B</td></tr> <tr><td>V/R</td><td>B/W</td><td>L/B</td><td>P/B</td><td>LG</td><td>R/Y</td></tr> <tr><td>2R</td><td>2O</td><td></td><td>2I</td><td>2F</td><td>2C</td></tr> <tr><td>W/L</td><td>*</td><td></td><td>P</td><td>W/G</td><td>L/W</td></tr> </table> <table border="1"> <tr><td>3X</td><td>3U</td><td>3P</td><td>3M</td><td>3J</td><td>3D</td><td>3A</td></tr> <tr><td>*</td><td>BR/R</td><td>W/B</td><td>GY/R</td><td>B/O</td><td>G/B</td><td>B</td></tr> <tr><td>3Y</td><td>3V</td><td>3S</td><td>3Q</td><td>3N</td><td>3K</td><td>3H</td><td>3E</td><td>3B</td></tr> <tr><td>V/W</td><td>GY/L</td><td>R/B</td><td>G/W</td><td>*</td><td>*</td><td>*</td><td>L/O</td><td>B/R</td></tr> <tr><td>3Z</td><td>3W</td><td>3T</td><td>3O</td><td>3L</td><td>3I</td><td>3F</td><td>3C</td><td></td></tr> <tr><td>*</td><td>*</td><td>G/R</td><td>G/O</td><td>*</td><td>B/Y</td><td>BR/W</td><td>G/Y</td><td></td></tr> </table> <table border="1"> <tr><td>4AF</td><td>4AC</td><td>4Z</td><td>4U</td><td>4R</td><td>4O</td><td>4L</td><td>4D</td><td>4A</td></tr> <tr><td>W/R</td><td>V/G</td><td>P/B</td><td>*</td><td>V/Y</td><td>B/R</td><td>LG/R</td><td>Y</td><td>B/L</td></tr> <tr><td>4AG</td><td>4AD</td><td>4AA</td><td>4X</td><td>4V</td><td>4S</td><td>4P</td><td>4J</td><td>4B</td></tr> <tr><td>L/R</td><td>BR/B</td><td>R</td><td>P</td><td>G/B</td><td>*</td><td>R/L</td><td>W</td><td>BR/Y</td><td>G</td></tr> <tr><td>4AH</td><td>4AE</td><td>4AB</td><td></td><td>4W</td><td>4T</td><td>4N</td><td>4K</td><td>4I</td><td>4F</td><td>4C</td></tr> <tr><td>*</td><td>L/Y</td><td>R/G</td><td></td><td>L</td><td>GY</td><td>P/L</td><td>*</td><td>W/G</td><td>LG/B</td><td>BR</td></tr> </table>	2P	2W	2J	2G	2D	2A	D	R/W	Y/G	Y/R	V/G	Y/B	2Q	2N	2K	2H	2E	2B	V/R	B/W	L/B	P/B	LG	R/Y	2R	2O		2I	2F	2C	W/L	*		P	W/G	L/W	3X	3U	3P	3M	3J	3D	3A	*	BR/R	W/B	GY/R	B/O	G/B	B	3Y	3V	3S	3Q	3N	3K	3H	3E	3B	V/W	GY/L	R/B	G/W	*	*	*	L/O	B/R	3Z	3W	3T	3O	3L	3I	3F	3C		*	*	G/R	G/O	*	B/Y	BR/W	G/Y		4AF	4AC	4Z	4U	4R	4O	4L	4D	4A	W/R	V/G	P/B	*	V/Y	B/R	LG/R	Y	B/L	4AG	4AD	4AA	4X	4V	4S	4P	4J	4B	L/R	BR/B	R	P	G/B	*	R/L	W	BR/Y	G	4AH	4AE	4AB		4W	4T	4N	4K	4I	4F	4C	*	L/Y	R/G		L	GY	P/L	*	W/G	LG/B	BR	<p><b>B1-09 FUEL INJECTOR NO. 1 (INJ)</b></p>	<p><b>B1-10 FUEL INJECTOR NO. 2 (INJ)</b></p>	<p><b>B1-11 FUEL INJECTOR NO. 3 (INJ)</b></p>	<p><b>B1-12 FUEL INJECTOR NO. 4 (INJ)</b></p>
2P	2W	2J	2G	2D	2A																																																																																																																																																
D	R/W	Y/G	Y/R	V/G	Y/B																																																																																																																																																
2Q	2N	2K	2H	2E	2B																																																																																																																																																
V/R	B/W	L/B	P/B	LG	R/Y																																																																																																																																																
2R	2O		2I	2F	2C																																																																																																																																																
W/L	*		P	W/G	L/W																																																																																																																																																
3X	3U	3P	3M	3J	3D	3A																																																																																																																																															
*	BR/R	W/B	GY/R	B/O	G/B	B																																																																																																																																															
3Y	3V	3S	3Q	3N	3K	3H	3E	3B																																																																																																																																													
V/W	GY/L	R/B	G/W	*	*	*	L/O	B/R																																																																																																																																													
3Z	3W	3T	3O	3L	3I	3F	3C																																																																																																																																														
*	*	G/R	G/O	*	B/Y	BR/W	G/Y																																																																																																																																														
4AF	4AC	4Z	4U	4R	4O	4L	4D	4A																																																																																																																																													
W/R	V/G	P/B	*	V/Y	B/R	LG/R	Y	B/L																																																																																																																																													
4AG	4AD	4AA	4X	4V	4S	4P	4J	4B																																																																																																																																													
L/R	BR/B	R	P	G/B	*	R/L	W	BR/Y	G																																																																																																																																												
4AH	4AE	4AB		4W	4T	4N	4K	4I	4F	4C																																																																																																																																											
*	L/Y	R/G		L	GY	P/L	*	W/G	LG/B	BR																																																																																																																																											
	<p><b>B1-18 VTCS SOLENOID VALVE (EM)</b></p>	<p><b>B1-19 EGR VALVE (EM)</b></p>	<p><b>B1-20 CRANKSHAFT POSITION SENSOR (EM)</b></p>	<p><b>B1-21 CAMSHAFT POSITION SENSOR (EM)</b></p>																																																																																																																																																	
			<p><b>B1-22 MASS AIR FLOW SENSOR (EM)</b></p>																																																																																																																																																		

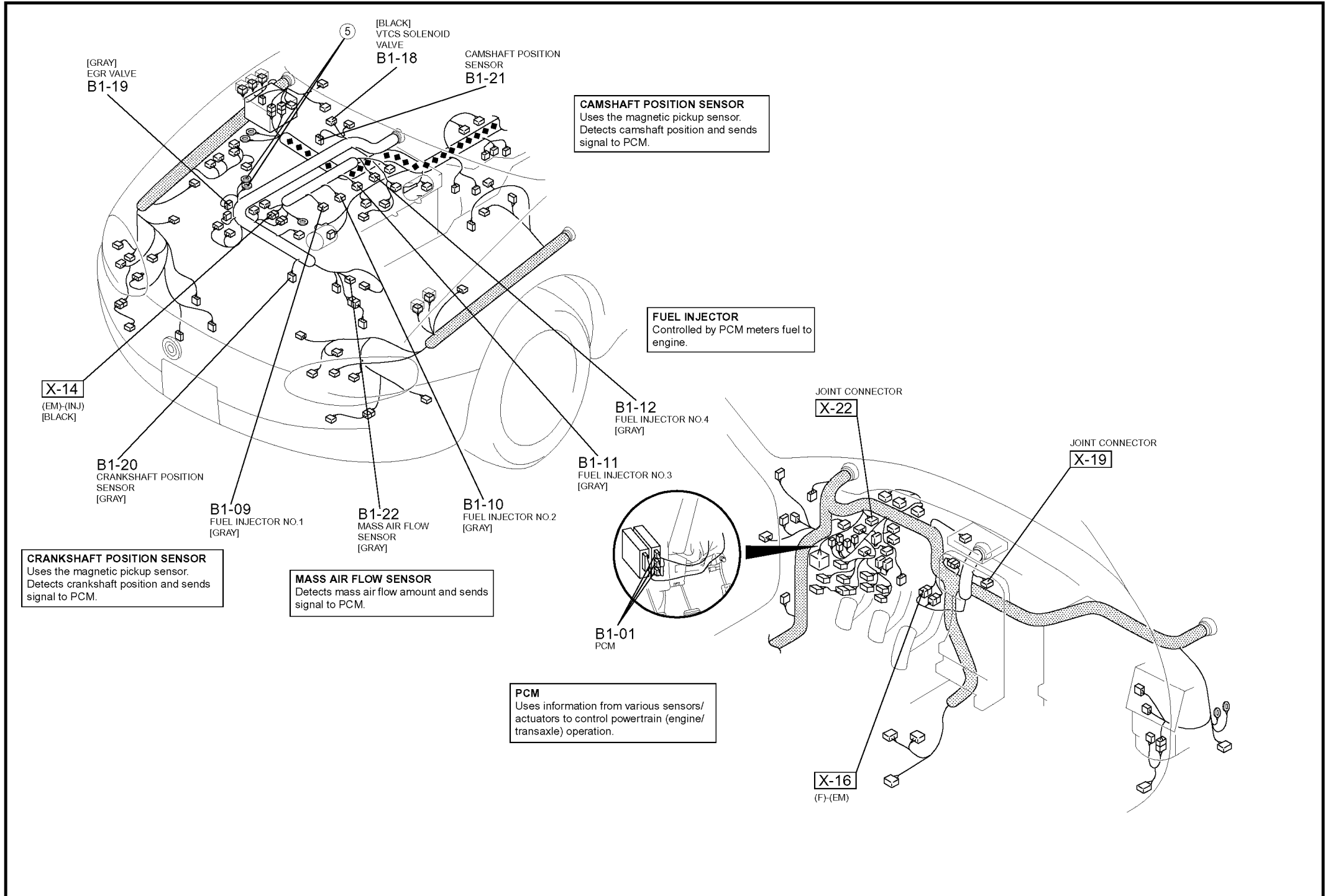

# Engine Control System \ B-1c

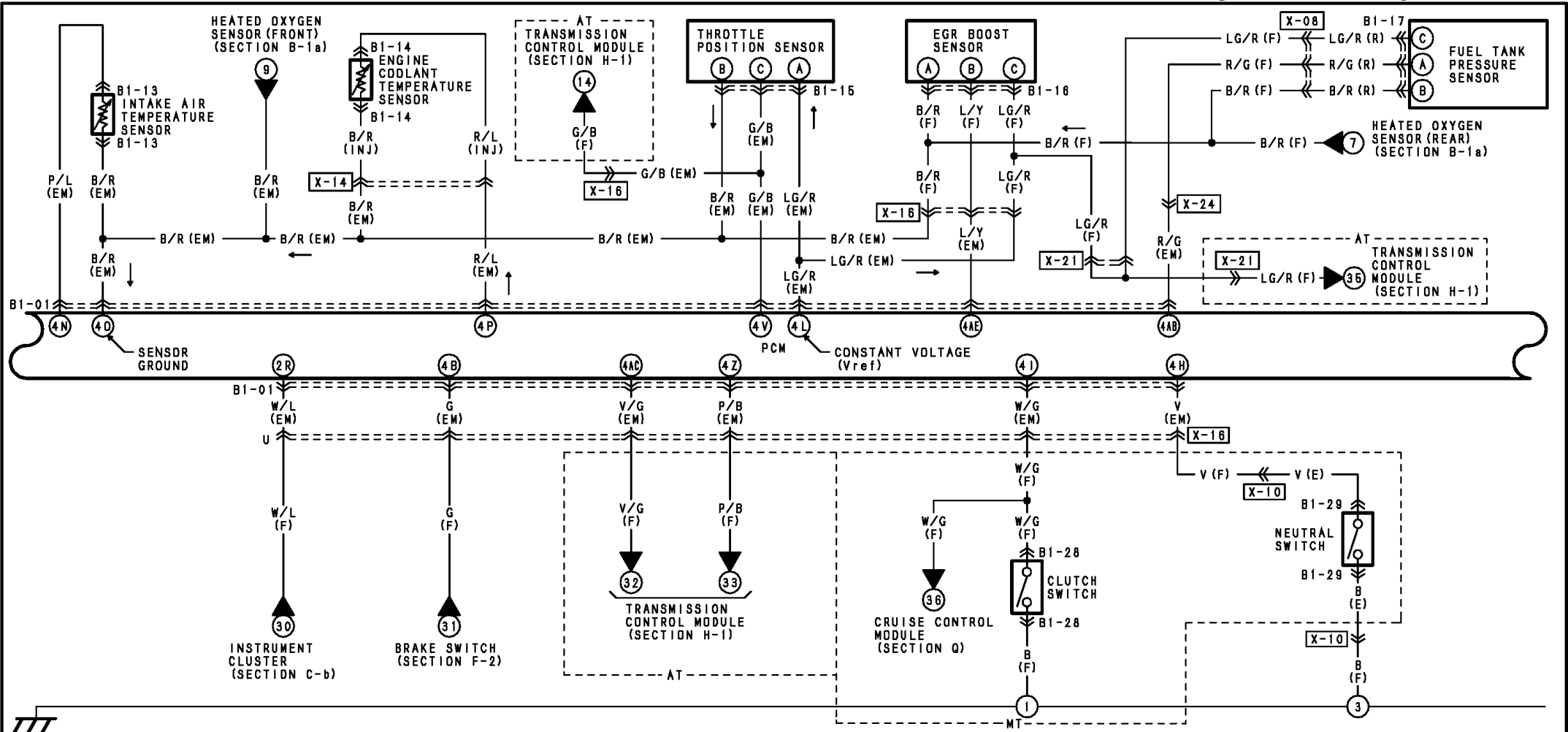

<p><b>B1-01 PCM (EM)</b></p>	<p><b>B1-13 INTAKE AIR TEMPERATURE SENSOR (EM)</b></p>	<p><b>B1-14 ENGINE COOLANT TEMPERATURE SENSOR (INJ)</b></p>	<p><b>B1-15 THROTTLE POSITION SENSOR (EM)</b></p>	
	<p><b>B1-16 EGR BOOST SENSOR (F)</b></p>	<p><b>B1-17 FUEL TANK PRESSURE SENSOR (R)</b></p>	<p><b>B1-28 CLUTCH SWITCH (F)</b></p> <p>(MT)</p>	<p><b>B1-29 NEUTRAL SWITCH (E)</b></p> <p>(MT)</p>

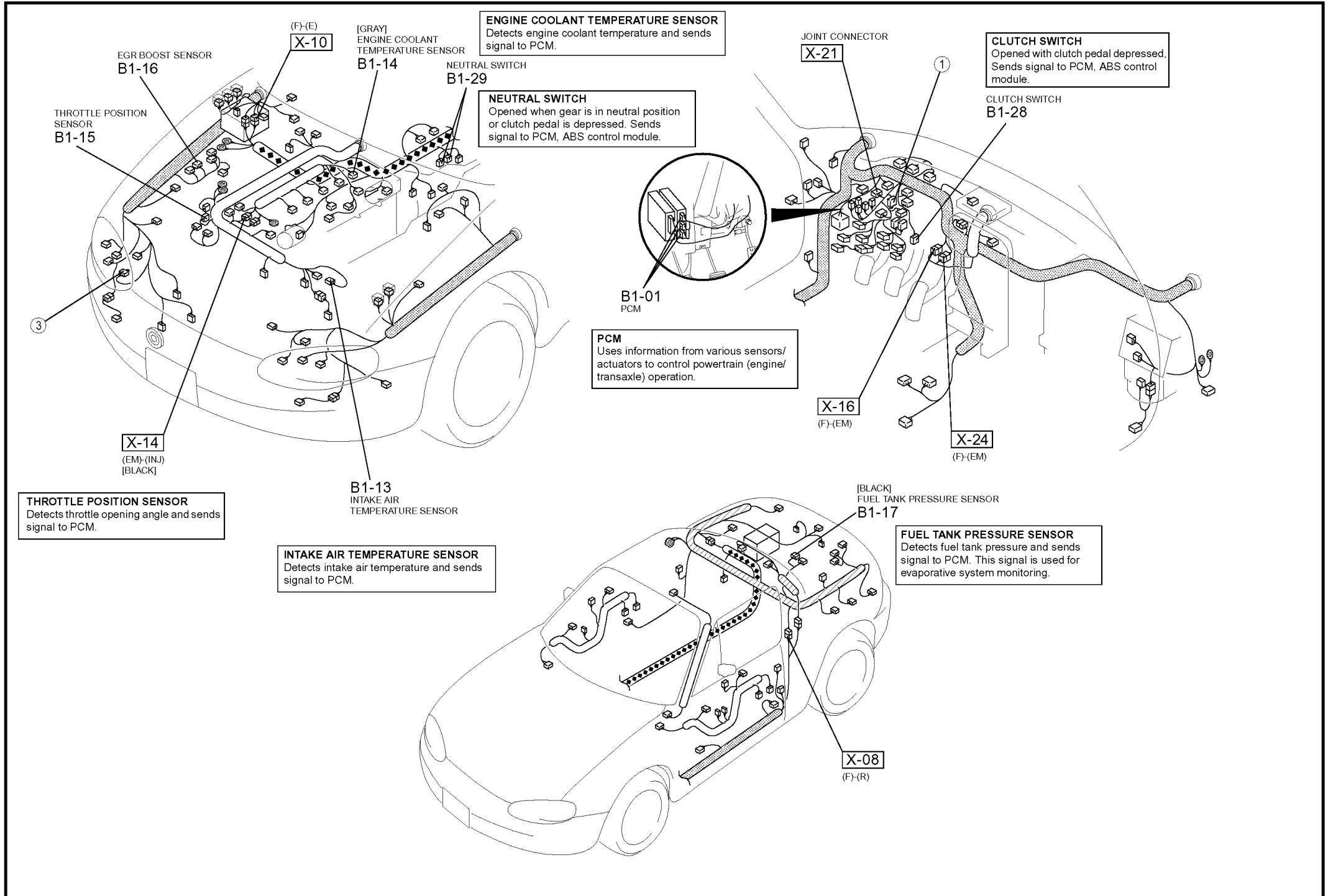

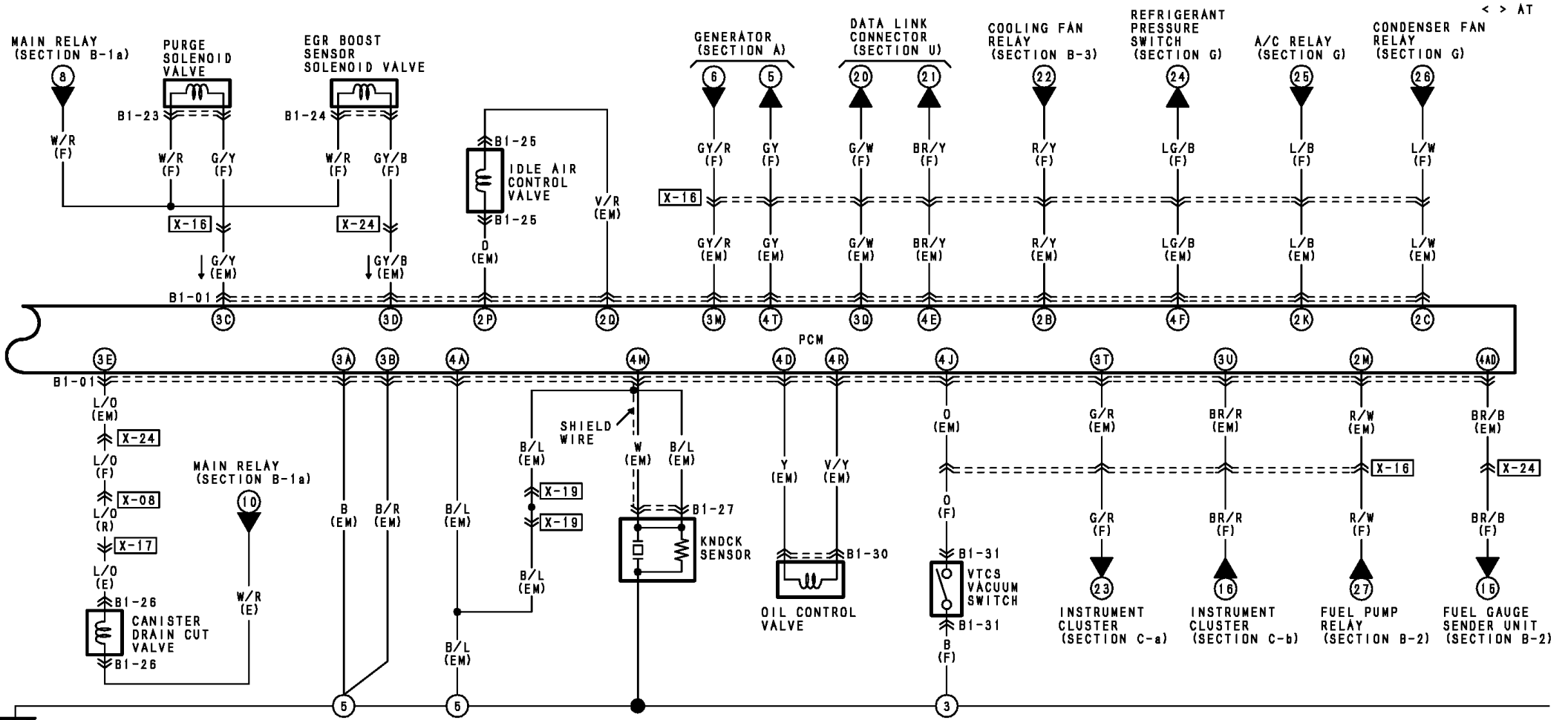

B1-01 PCM (EM)

2P	2W	2J	2G	2D	2A
D	R/W	Y/G	Y/R	V/G	Y/B
2Q	2N	2K	2H	2E	2B
V/R	B/W	L/B	P/B	LG	R/Y
2R	2O		2I	2F	2C
W/L	*		P	W/G	L/W

3X	3U	3P	3M	3J	3D	3A
*	BR/R	W/B	GY/R	B/O	GY/B	B
3Y	3V	3S	3Q	3N	3H	3E
V/W	GY/L	R/B	G/W	*	*	L/O
3Z	3W	3T	3O	3L	3I	3F
*	*	G/R	G/O	*	B/Y	BR/W
						3C
						G/Y

4AF	4AC	4Z	4U	4R	4O	4L	4D	4A
W/R	V/G	P/B	*	V/Y	B/R	LG/R	Y	B/L
4AG	4AD	4AA	4X	4Y	4S	4P	4M	4H
L/R	BR/B	R	P	G/B	*	R/L	W	V
4AH	4AE	4AB		4W	4T	4N	4K	4F
*	L/Y	R/G		L	GY	P/L	*	W/G
								4E
								BR/Y
								G
								4C
								BR

B1-23 PURGE SOLENOID VALVE (F)



B1-24 EGR BOOST SENSOR SOLENOID VALVE (F)

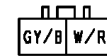

B1-25 IDLE AIR CONTROL VALVE (EM)



B1-26 CANISTER DRAIN CUT VALVE (E)



B1-27 KNOCK SENSOR (EM)

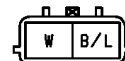

B1-30 OIL CONTROL VALVE (EM)



B1-31 VTCS VACUUM SWITCH (F)



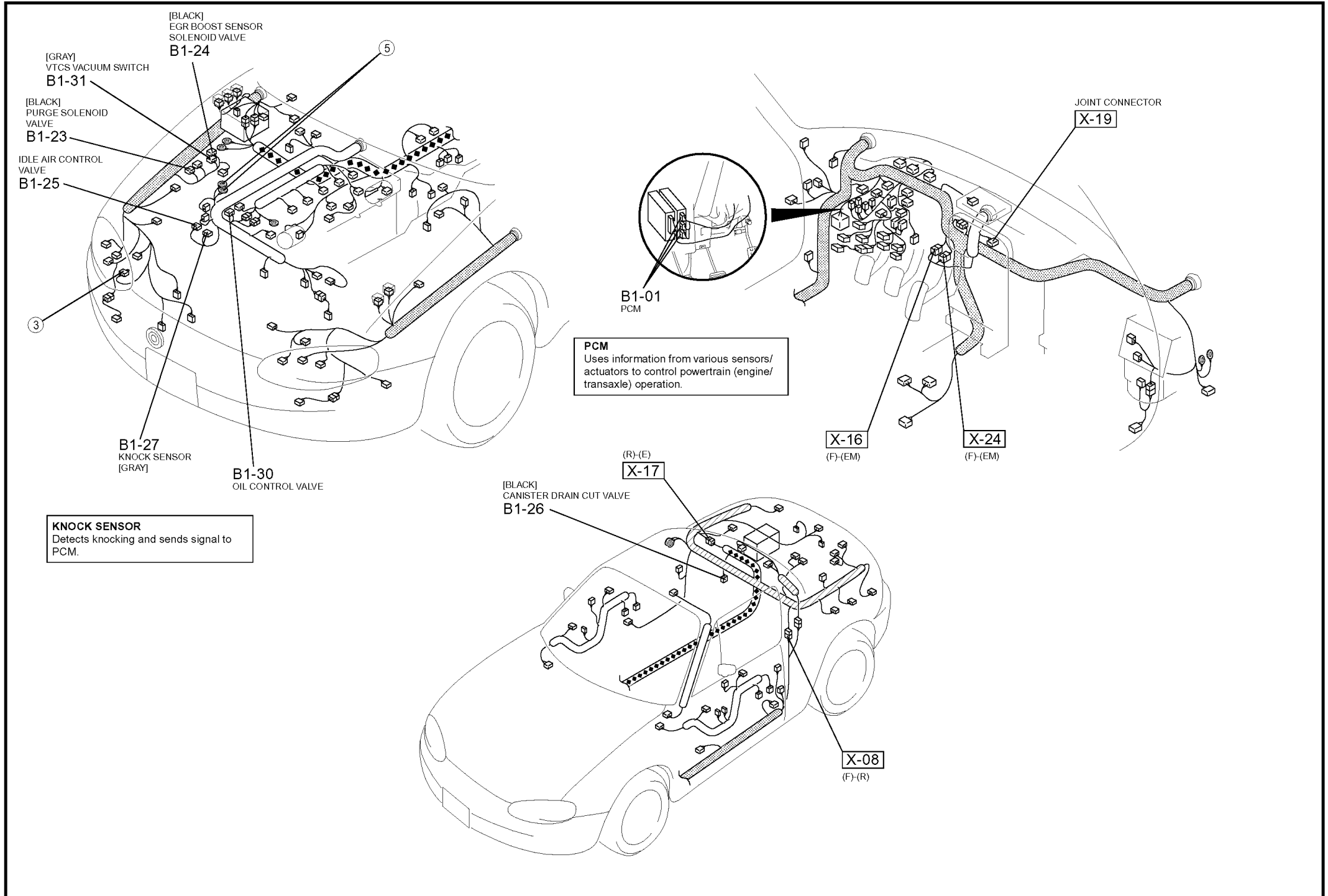

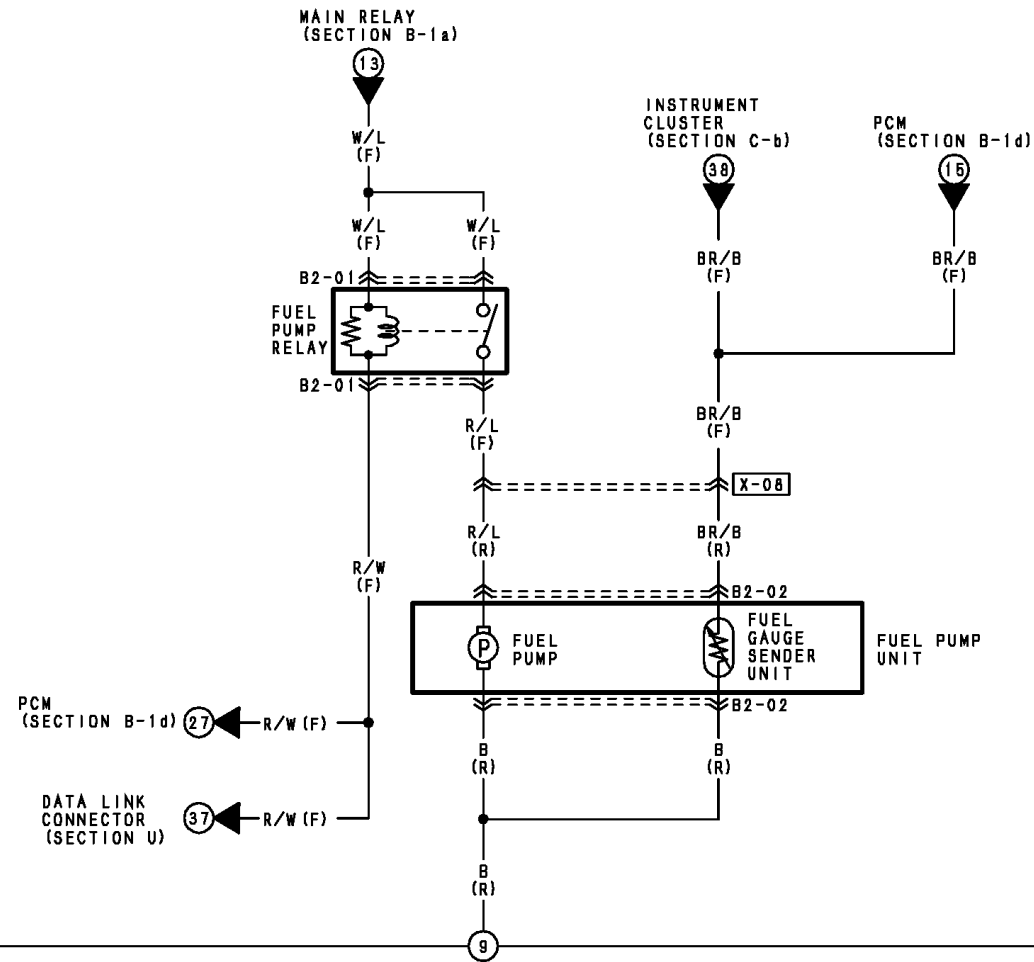

B2-01 FUEL PUMP RELAY (F)

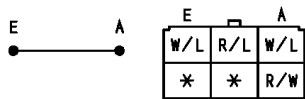

B2-02 FUEL PUMP UNIT (R)

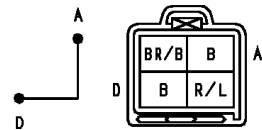



HARNESS SYMBOL :  (F)  (E)  (R)

# Fuel Control System \ B-2

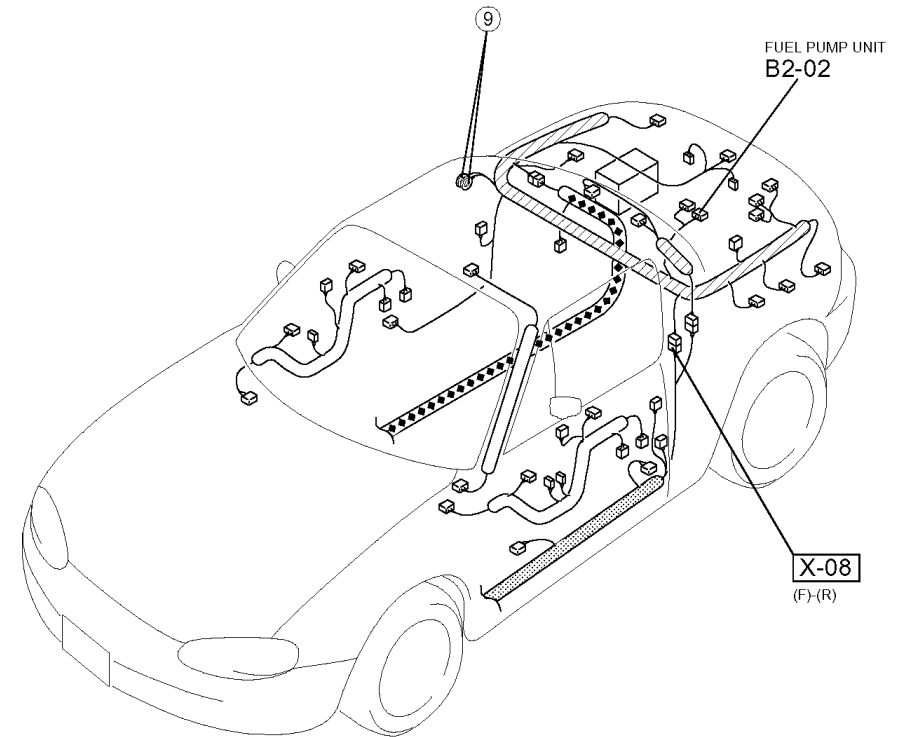
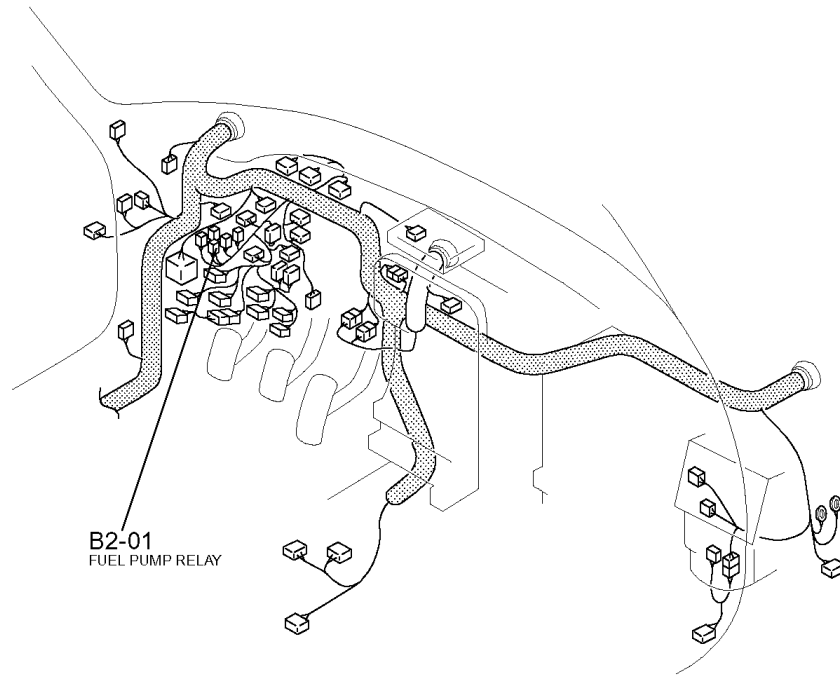

# Cooling Fan System \ B-3

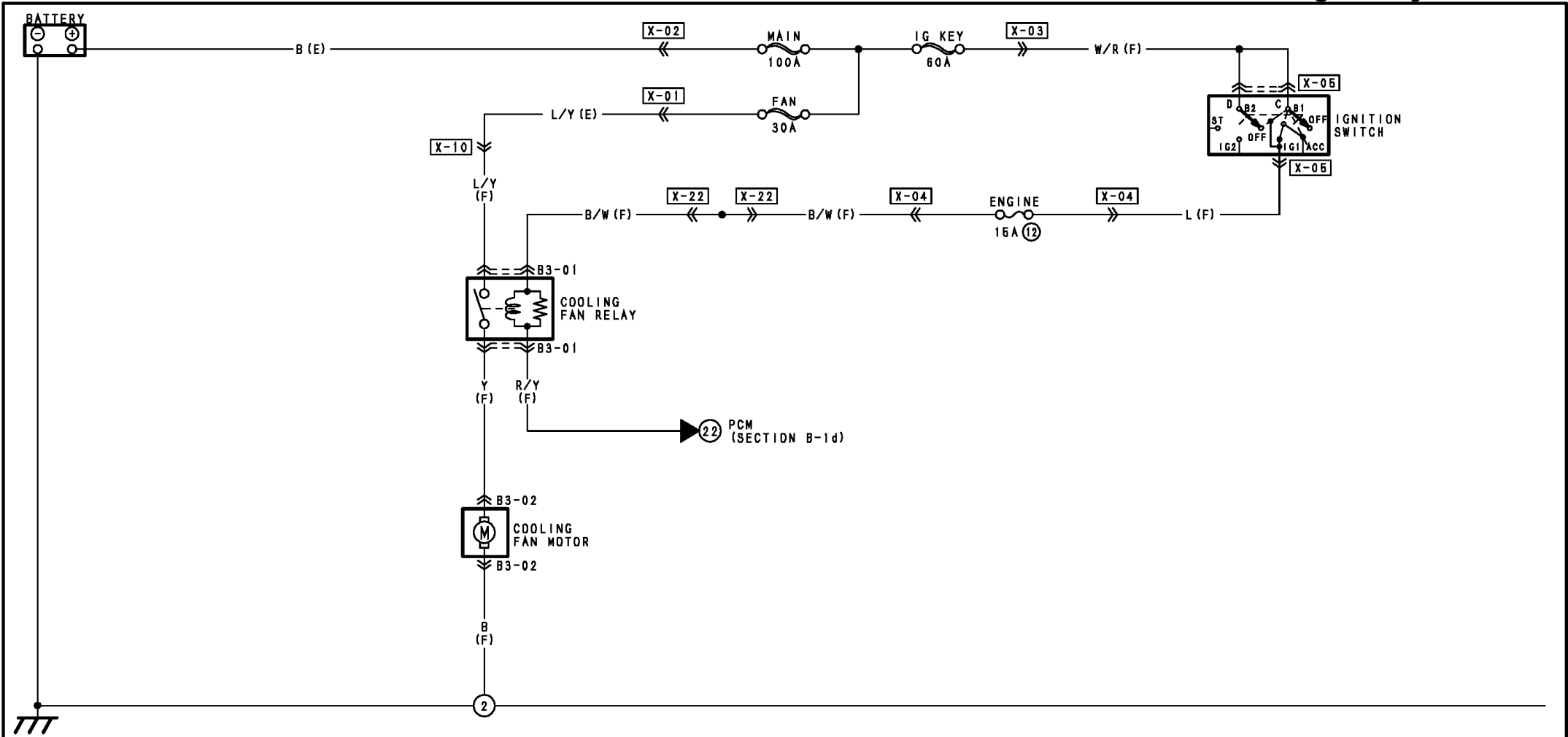

B3-01 COOLING FAN RELAY (F)

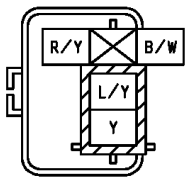

B3-02 COOLING FAN MOTOR (F)



B3-01 COOLING FAN RELAY (F)	B3-02 COOLING FAN MOTOR (F)					
						

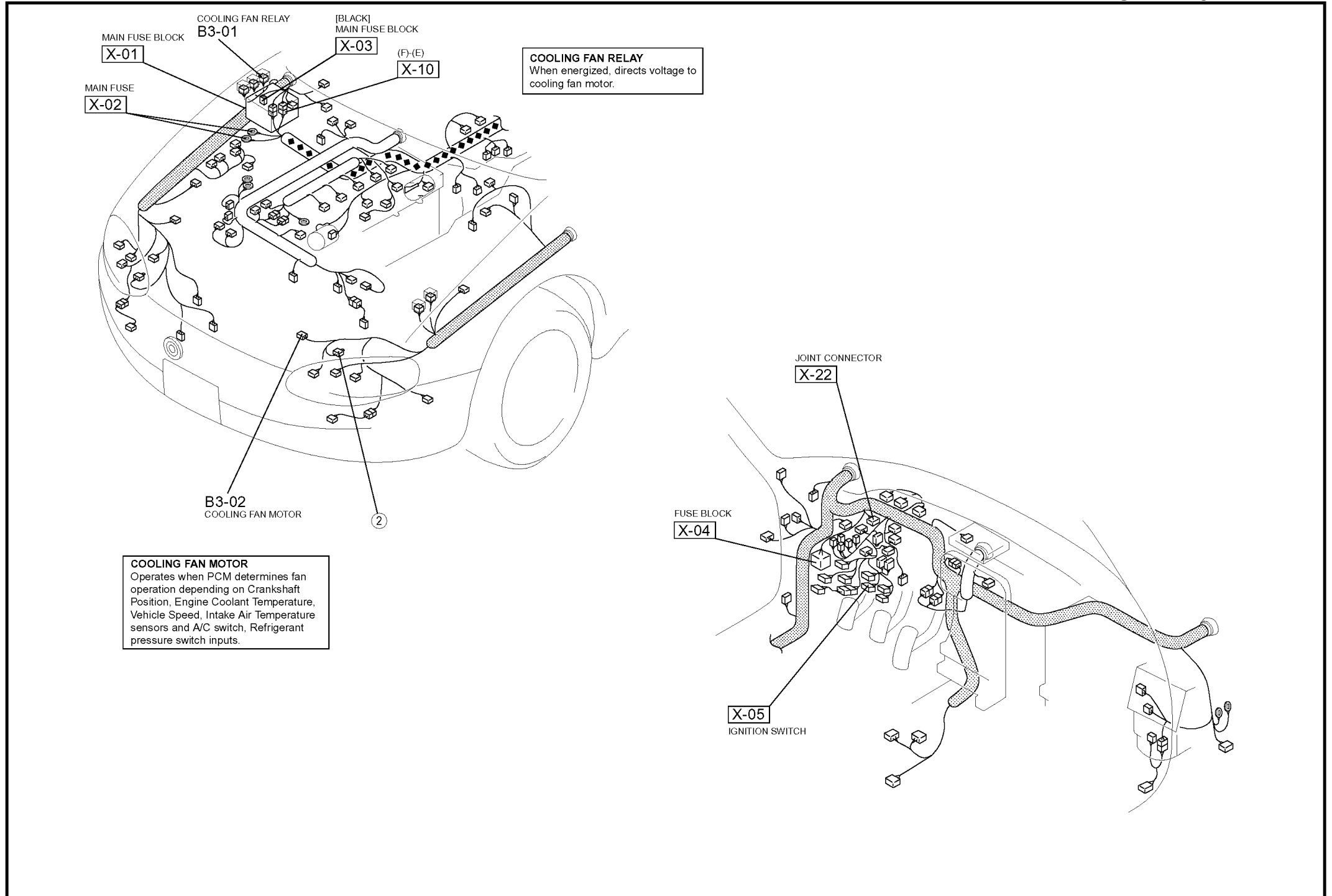

# Instrument Cluster \ C-a

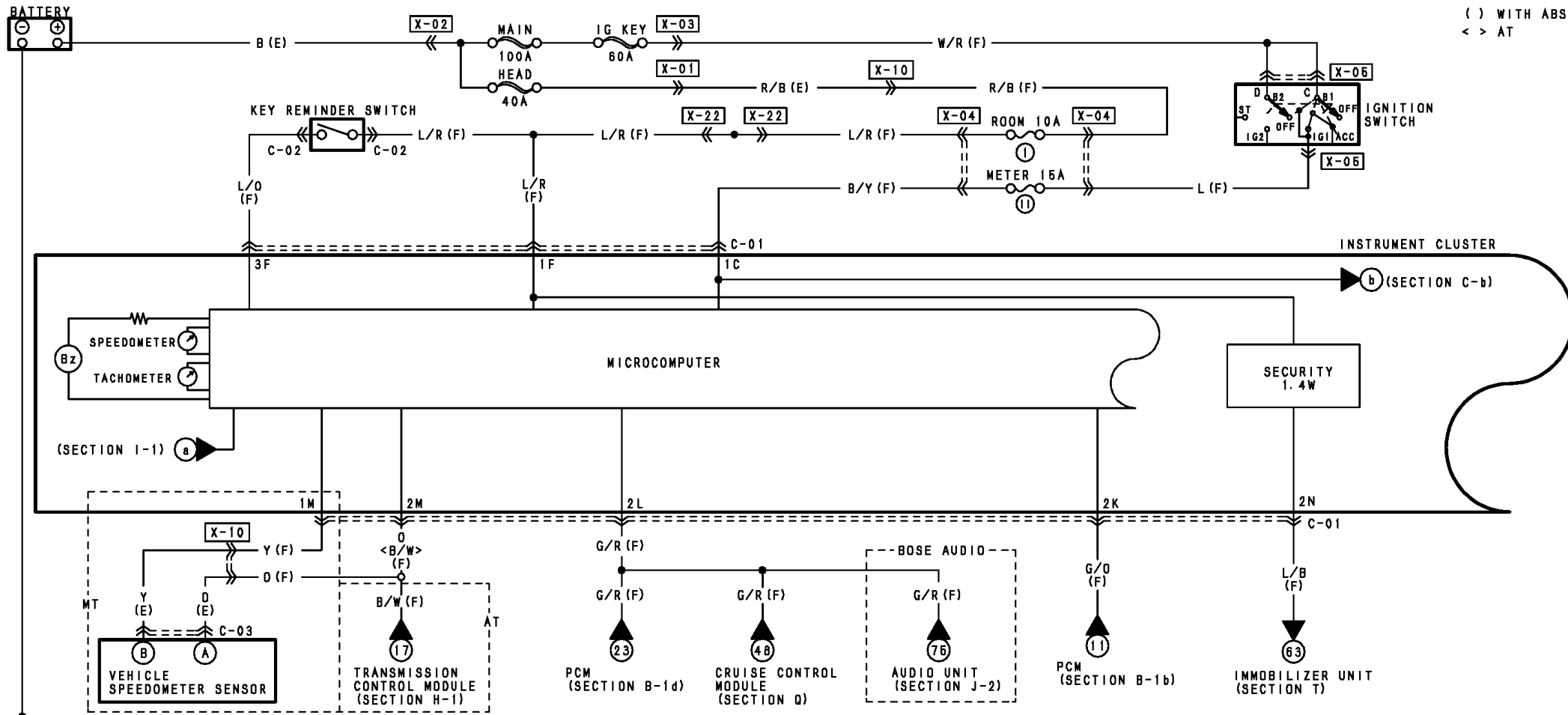

C-01 INSTRUMENT CLUSTER (F)

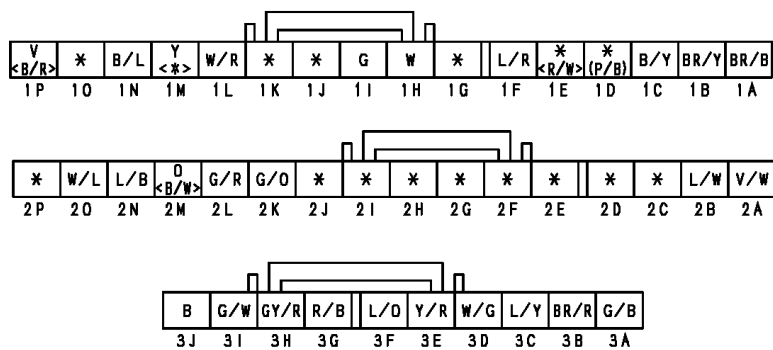

C-02 KEY REMINDER SWITCH (F)

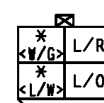

C-03 VEHICLE SPEEDOMETER SENSOR (E)

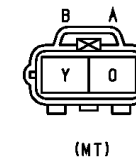

HARNESS SYMBOL :  (F)  (E)  (R)

# Instrument Cluster \ C-a

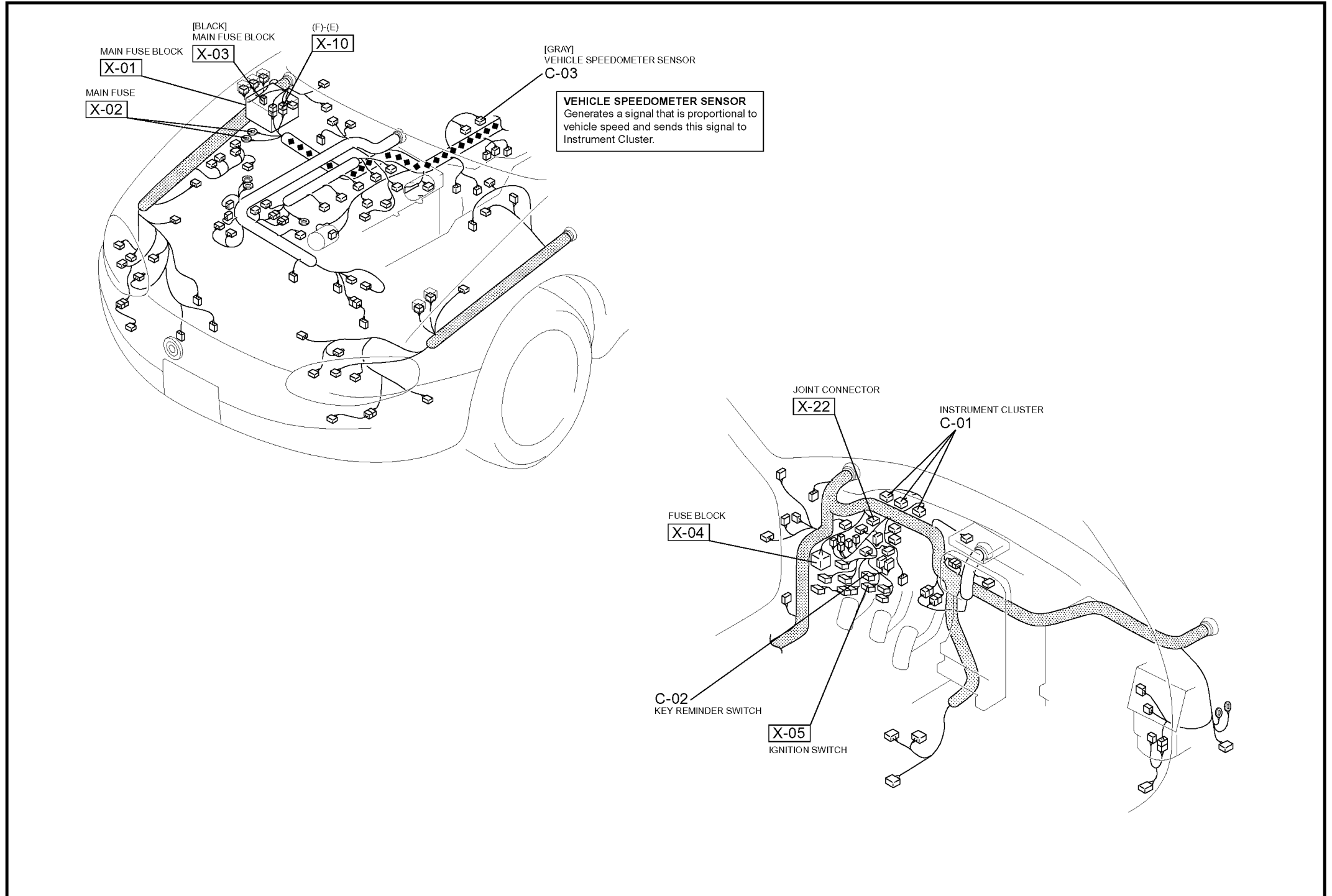

# Instrument Cluster \ C-b

( ) WITH ABS  
< > AT

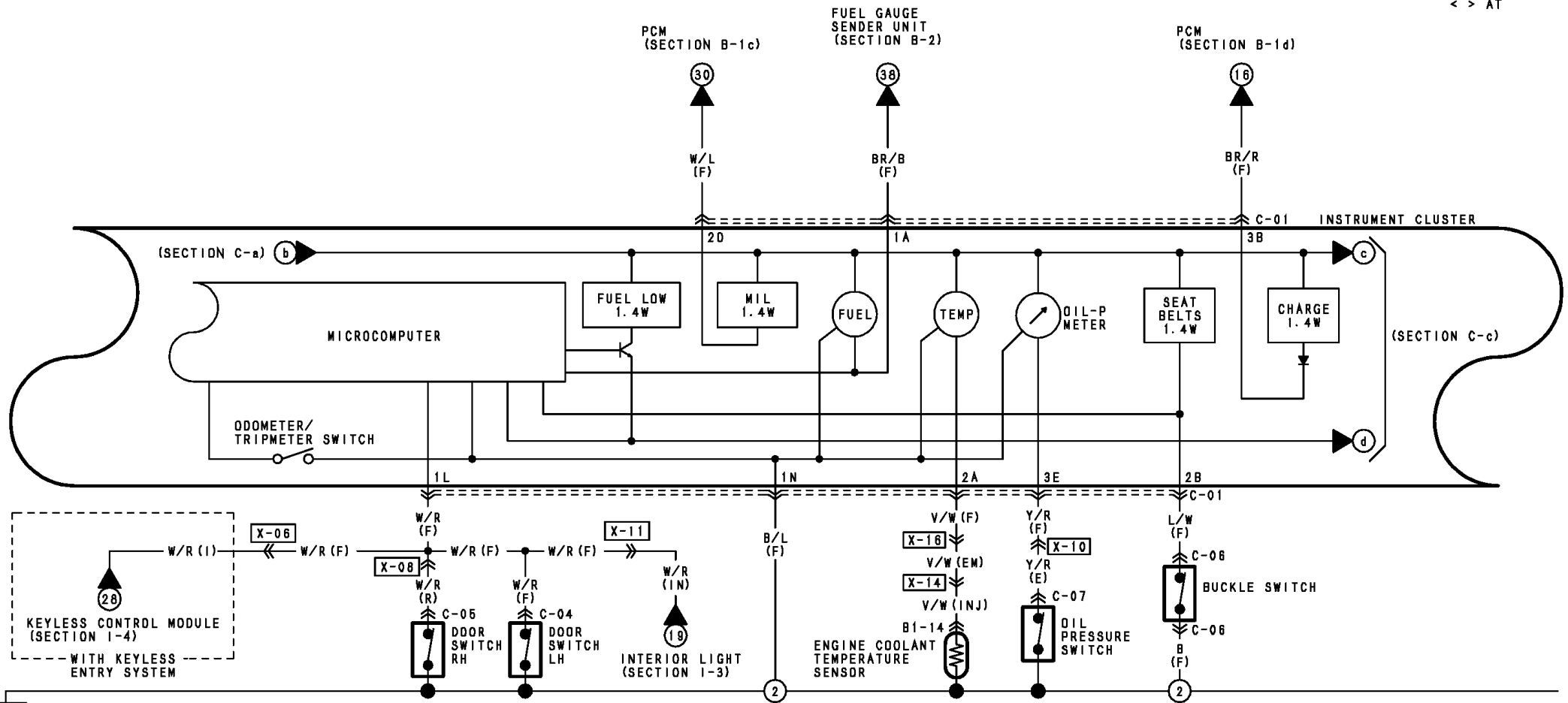

C-01 INSTRUMENT CLUSTER (F)

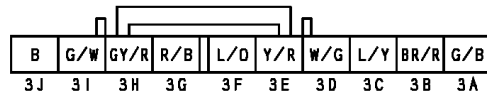
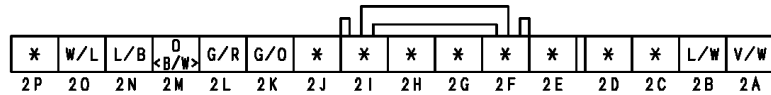
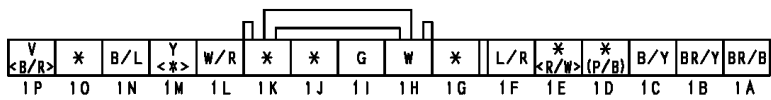

C-04 DOOR SWITCH LH (F)



C-05 DOOR SWITCH RH (R)



C-06 BUCKLE SWITCH (F)

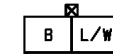

C-07 OIL PRESSURE SWITCH (E)



B1-14 ENGINE COOLANT TEMPERATURE SENSOR (INJ)

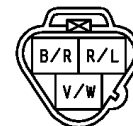

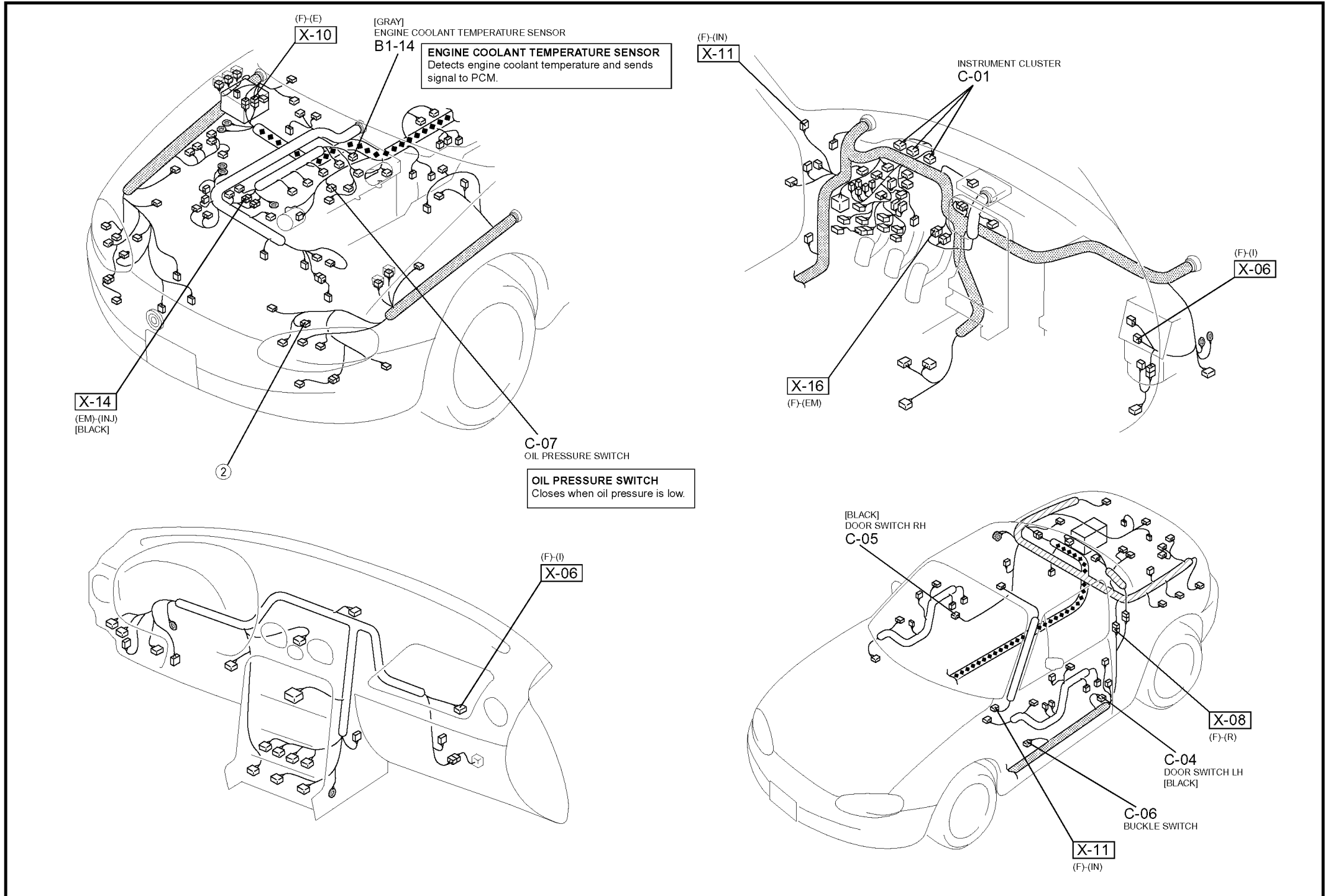

( ) WITH ABS < > AT [ ] WITH DRL

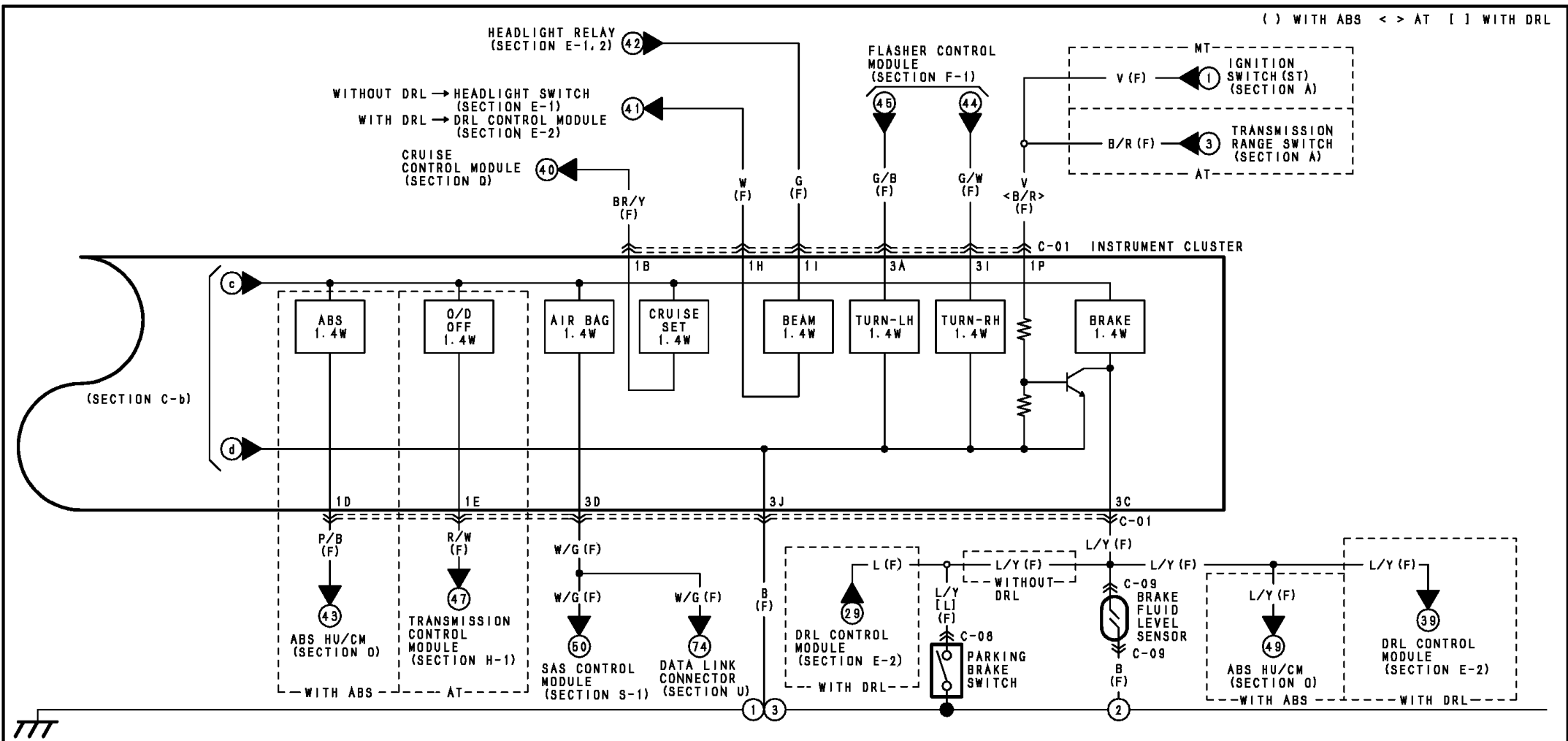

C-01 INSTRUMENT CLUSTER (F)

C-08 PARKING BRAKE SWITCH (F)

C-09 BRAKE FLUID LEVEL SENSOR (F)

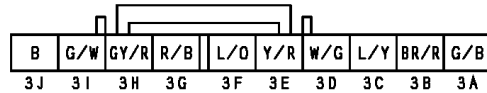
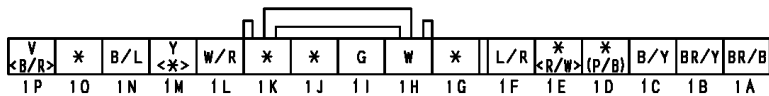



HARNESS SYMBOL :  (F)  (E)  (R)

# Instrument Cluster \ C-c

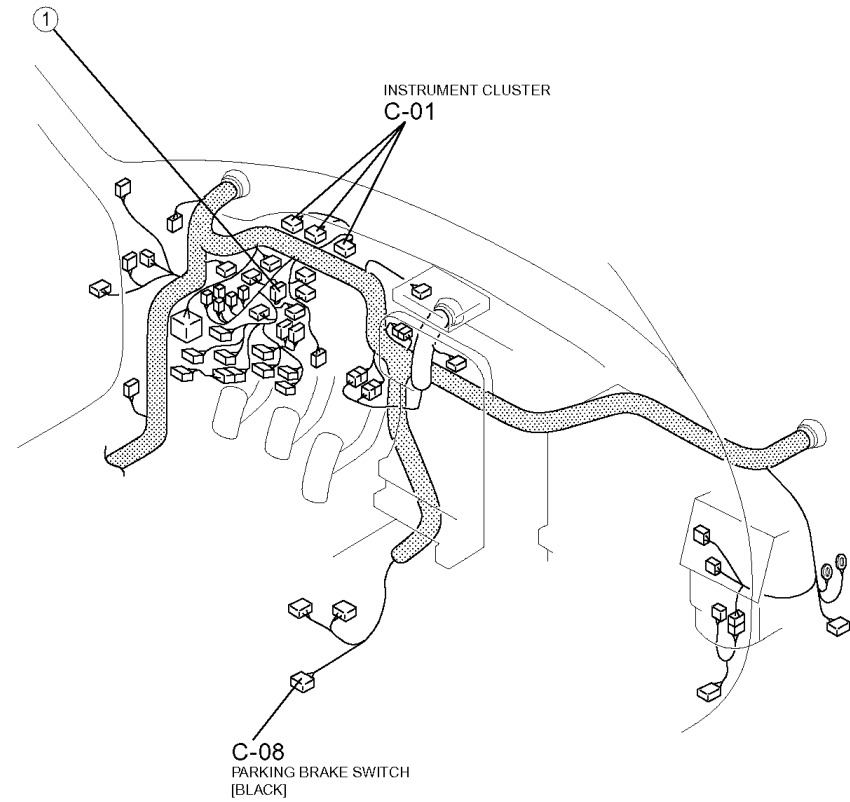
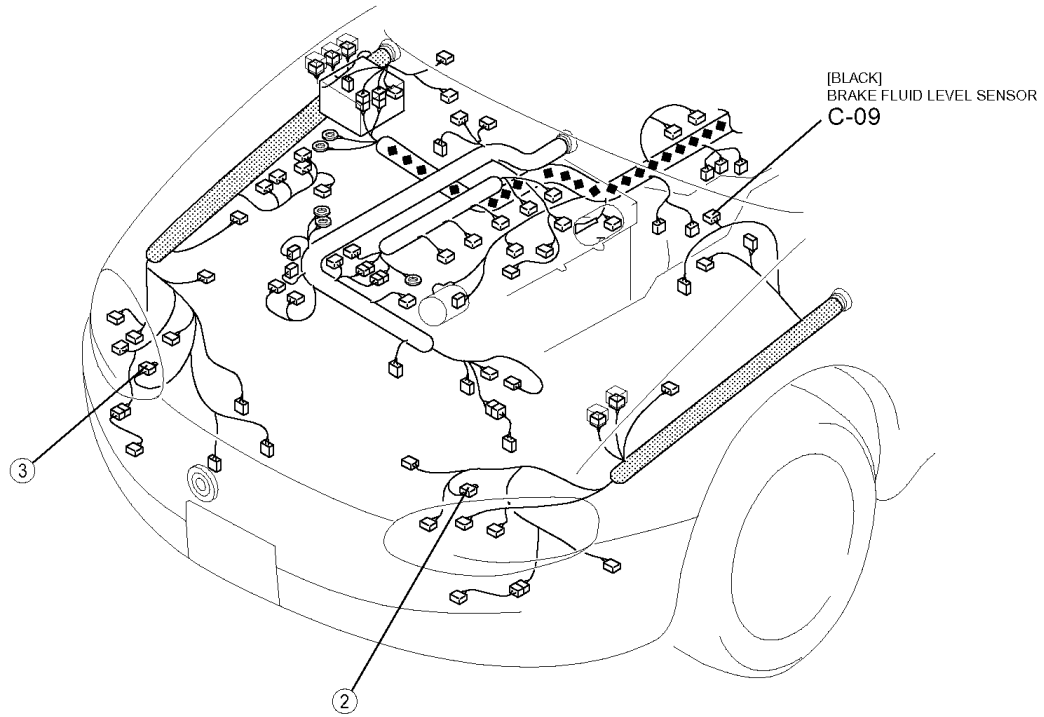

# Windshield Wiper and Washer \ D

( ) WITH DRL

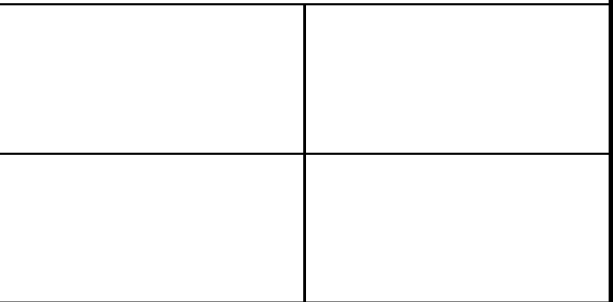
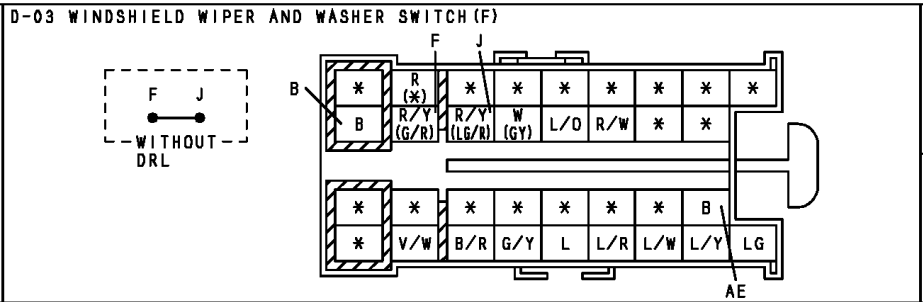
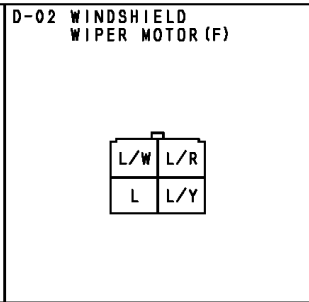
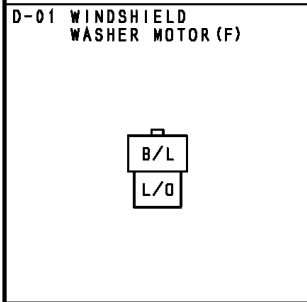
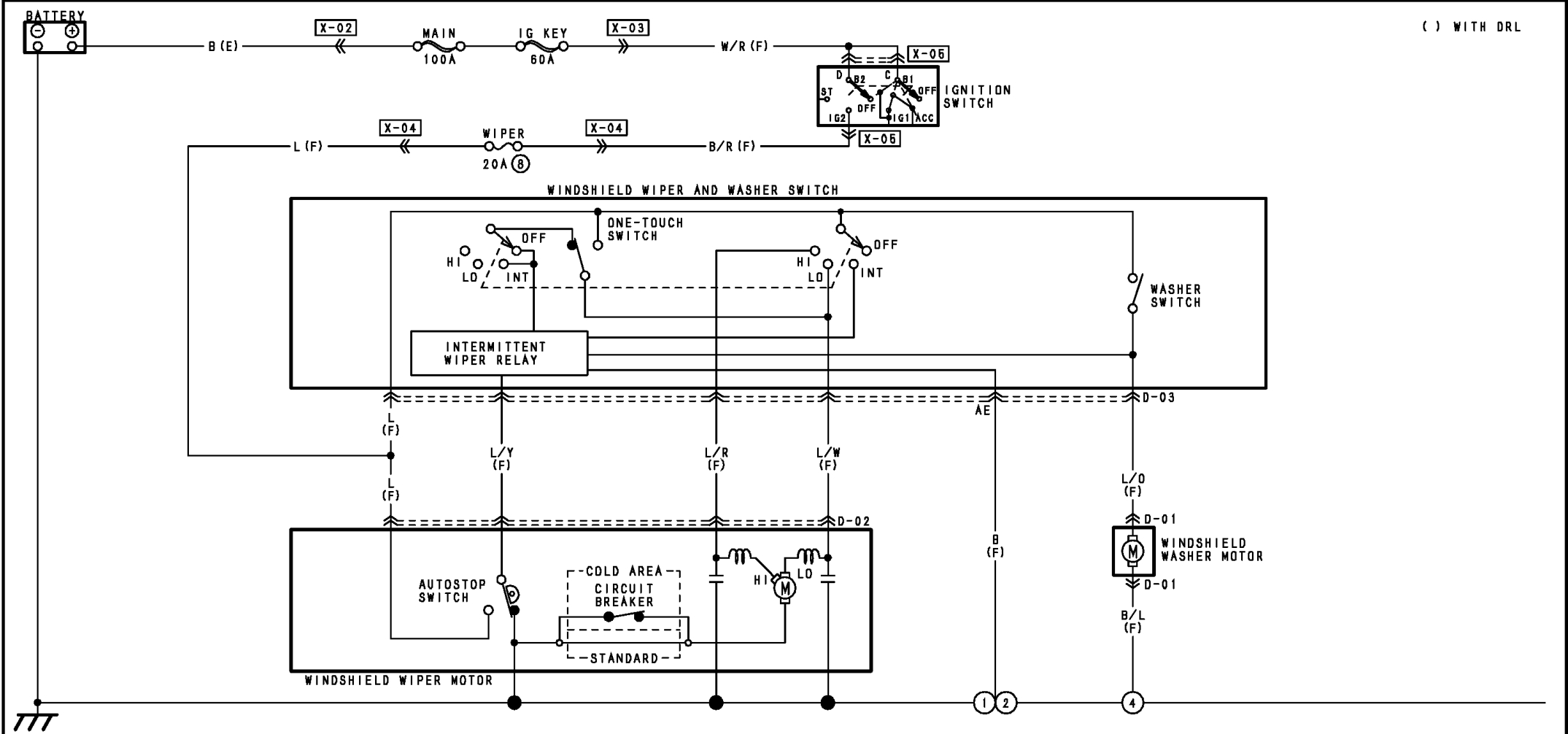

HARNESS SYMBOL :  (F)  (E)  (R)

# Windshield Wiper and Washer \ D

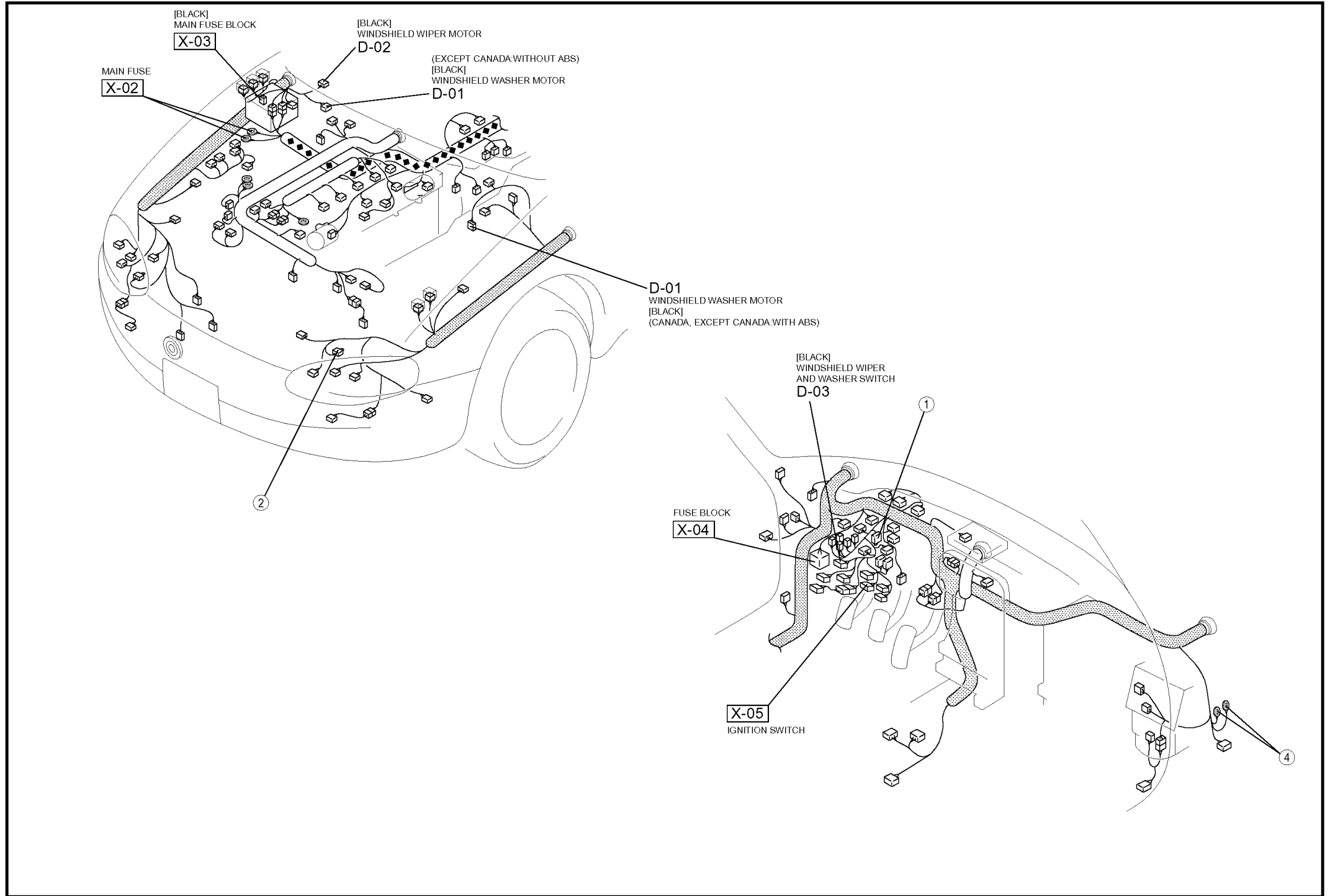



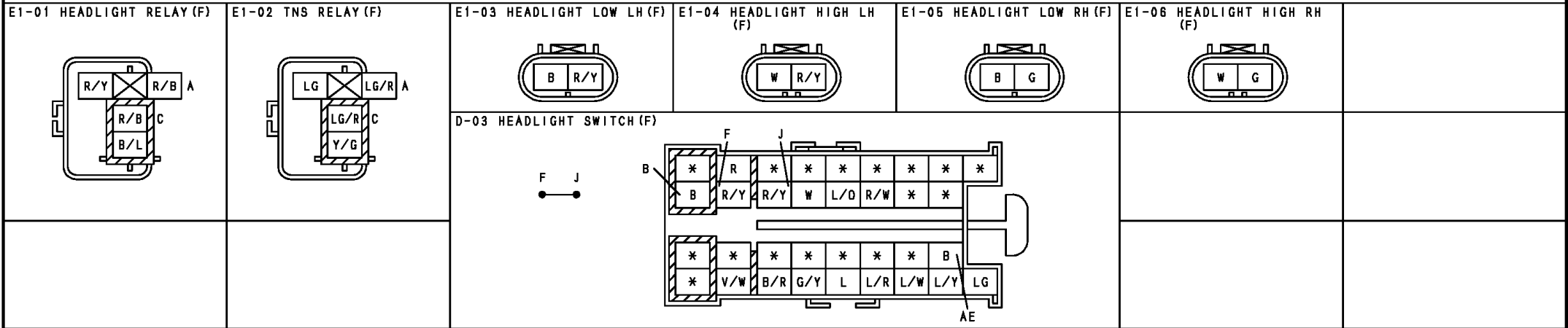
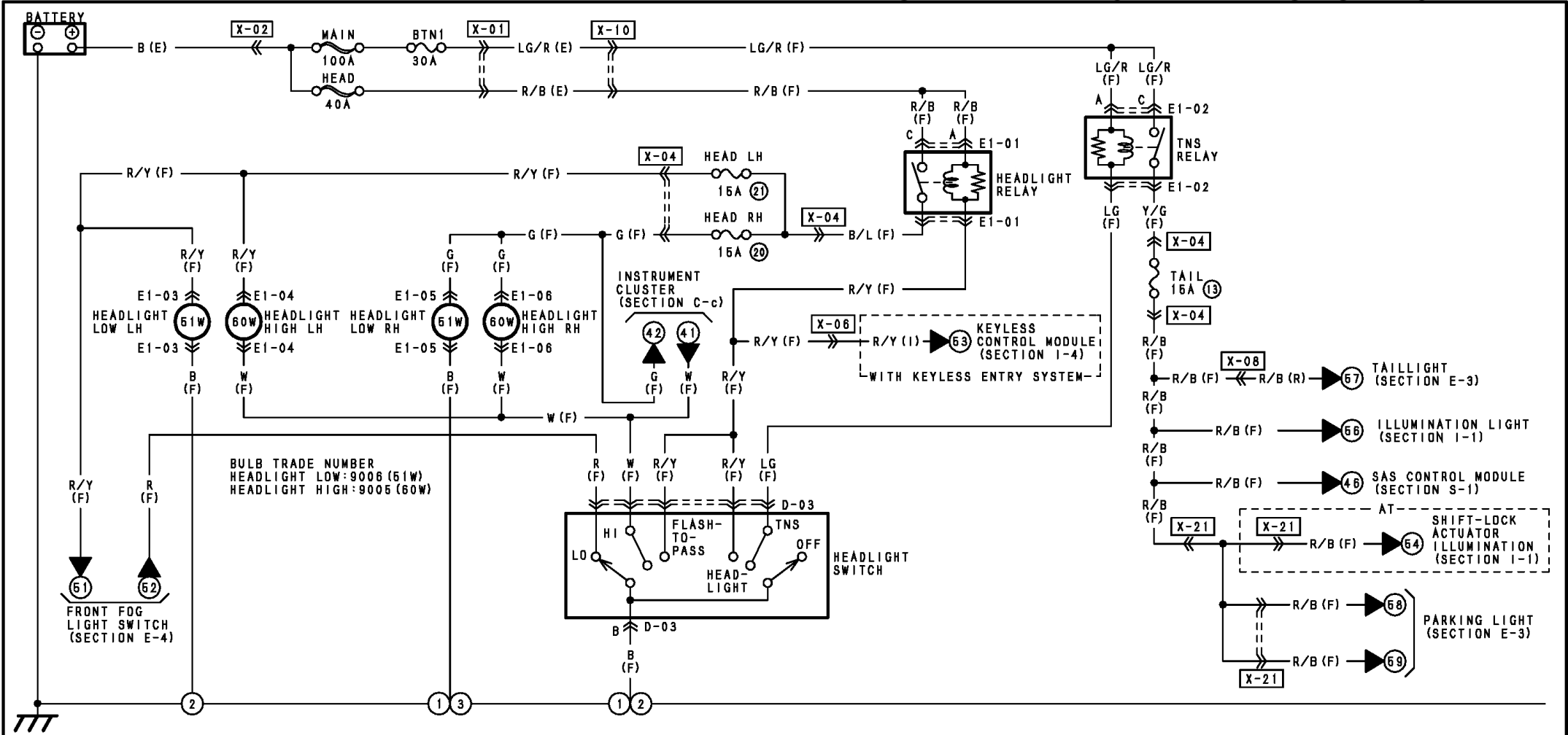

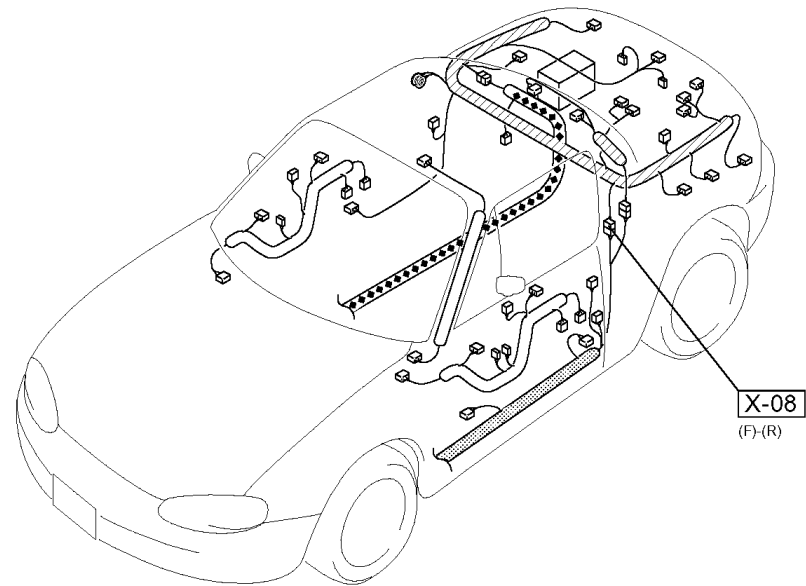
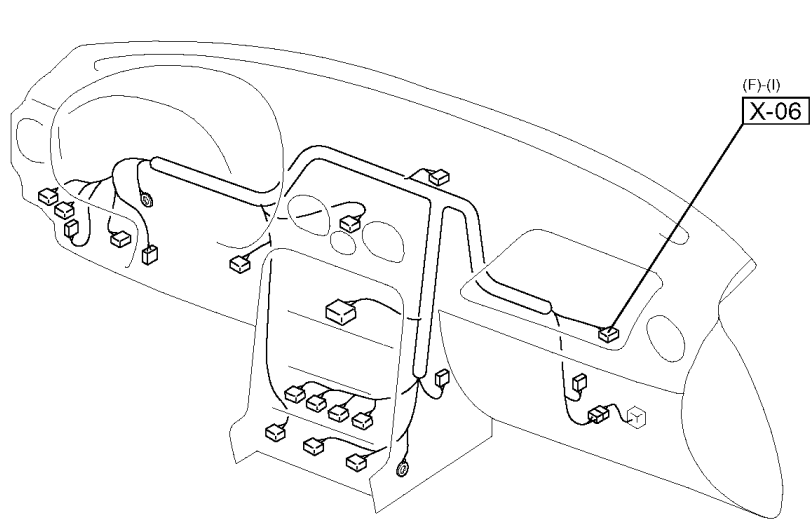
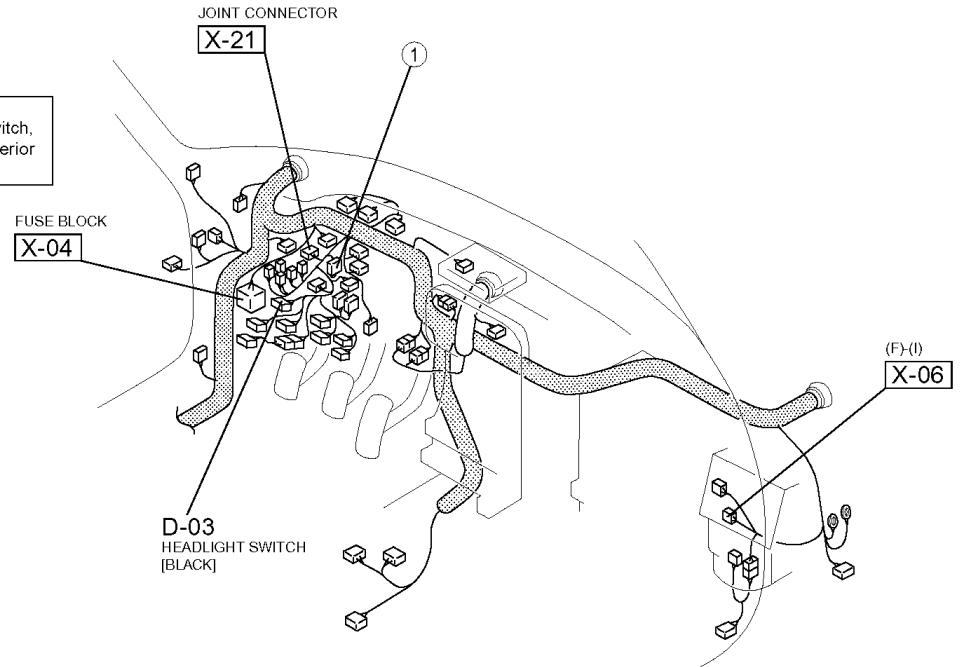
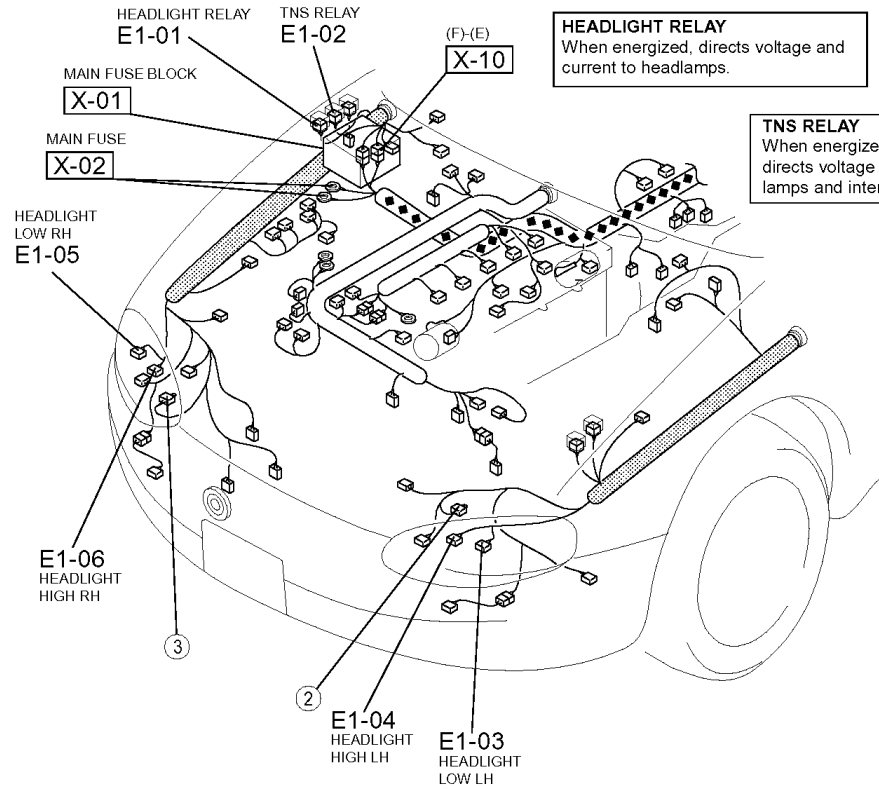
# Headlights (Without Daytime Running Lights System) \ E-1



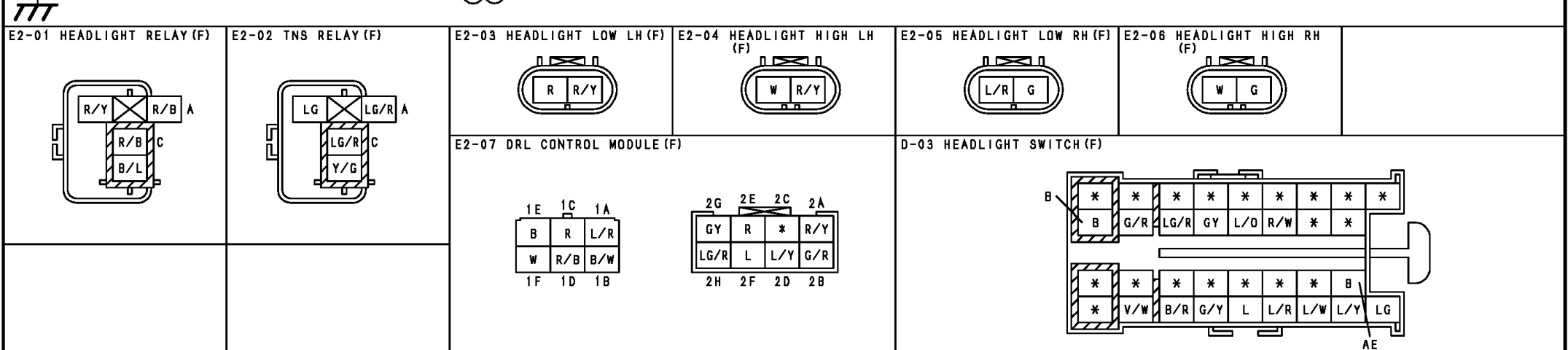
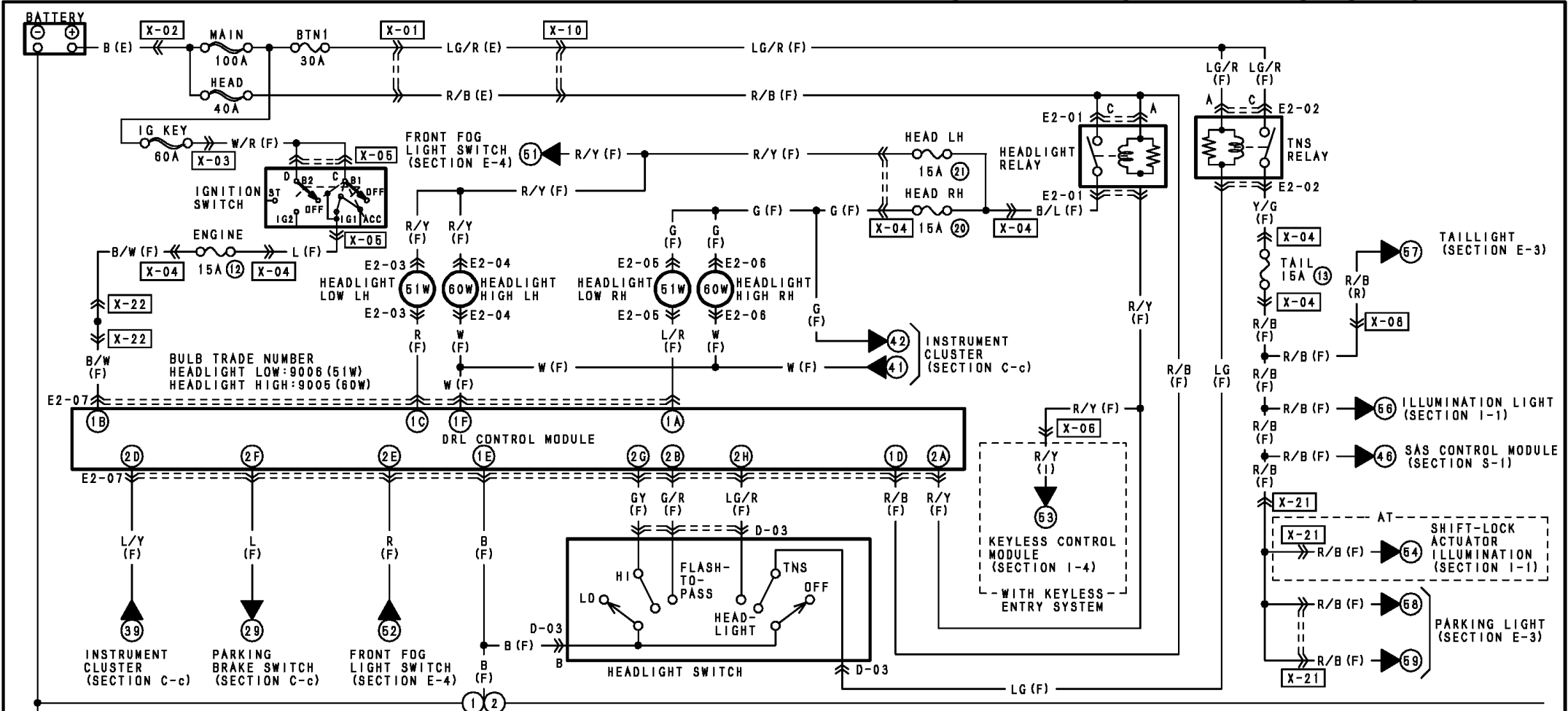

# Headlights (With Daytime Running Light System) | E-2



HARNESS SYMBOL :  (F)  (E)  (R)

# Headlights (With Daytime Running Light System) \ E-2

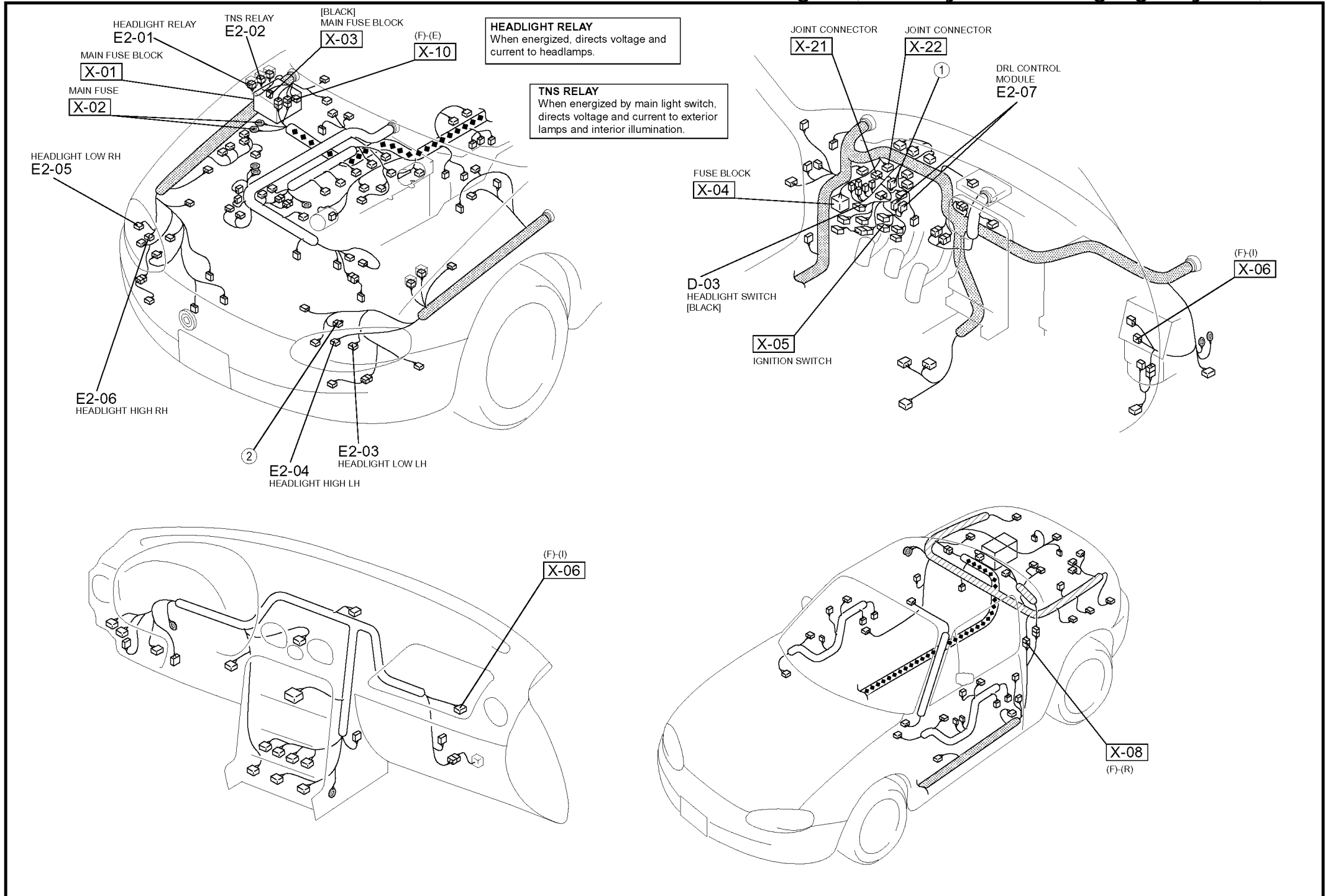

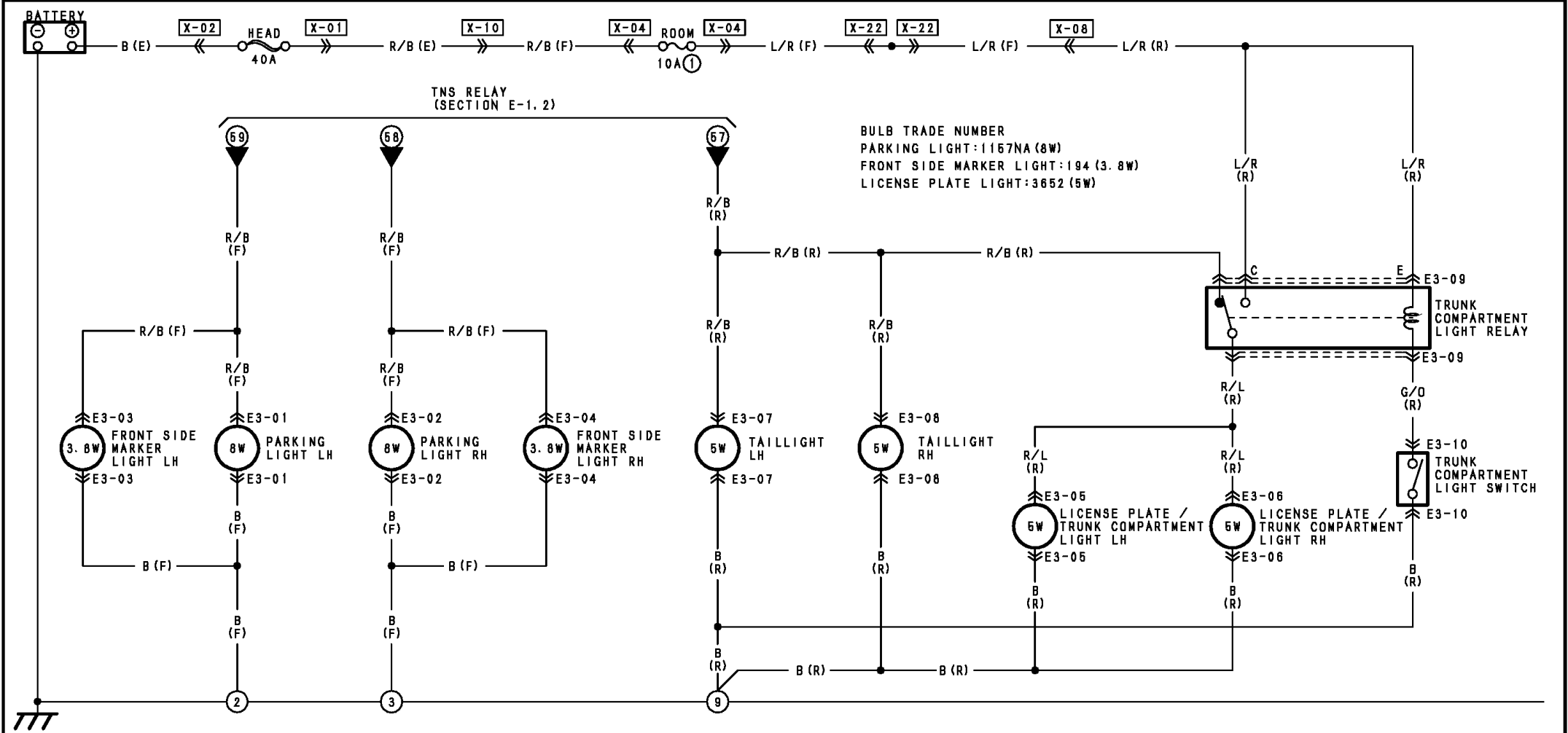

# Front Side Marker Lights \ License Plate Lights \ Parking Lights \ Taillights \ E-3

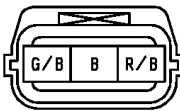
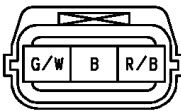
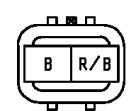
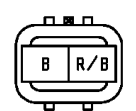
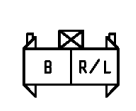
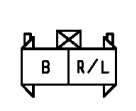
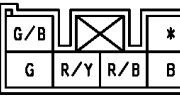
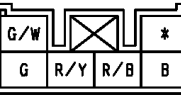
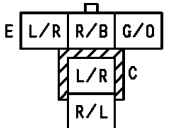
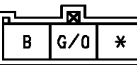

<p>E3-01 PARKING LIGHT LH (F)</p> 	<p>E3-02 PARKING LIGHT RH (F)</p> 	<p>E3-03 FRONT SIDE MARKER LIGHT LH (F)</p> 	<p>E3-04 FRONT SIDE MARKER LIGHT RH (F)</p> 	<p>E3-05 LICENSE PLATE / TRUNK COMPARTMENT LIGHT LH (R)</p> 	<p>E3-06 LICENSE PLATE / TRUNK COMPARTMENT LIGHT RH (R)</p> 
<p>E3-07 TAILLIGHT LH (R)</p> 	<p>E3-08 TAILLIGHT RH (R)</p> 	<p>E3-09 TRUNK COMPARTMENT LIGHT RELAY (R)</p> 	<p>E3-10 TRUNK COMPARTMENT LIGHT SWITCH (R)</p> 		



HARNES SYMBOL :  (F)  (E)  (R)

# Front Side Marker Lights \ License Plate Lights \ Parking Lights \ Taillights \ E-3

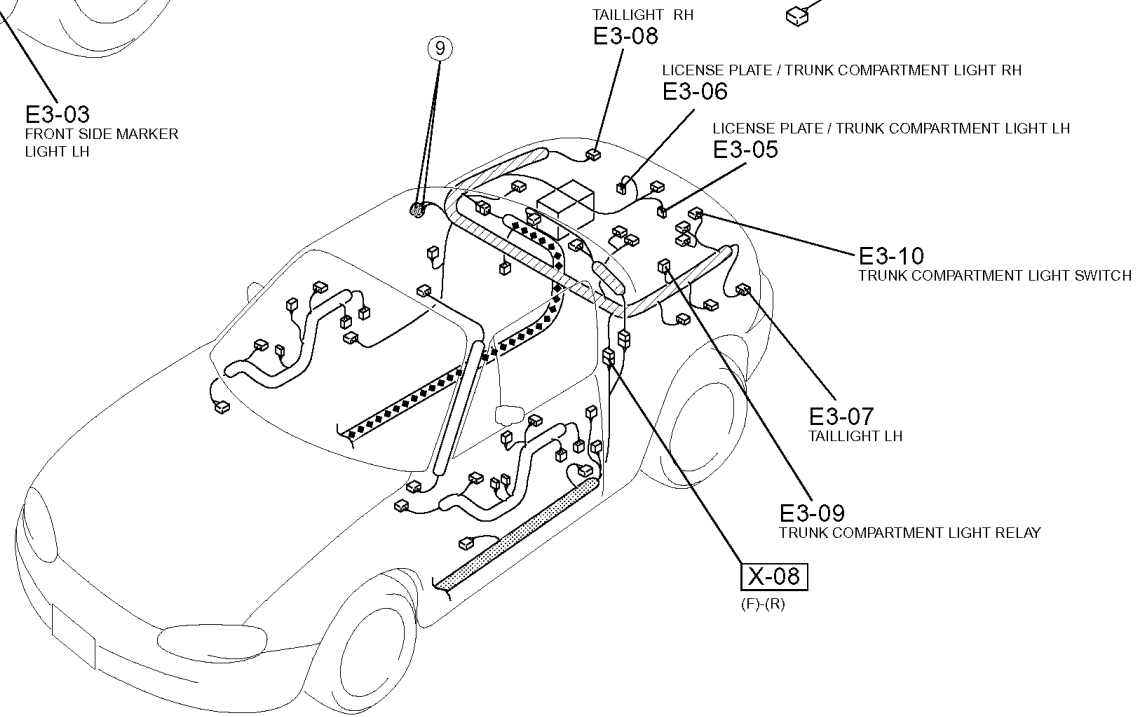
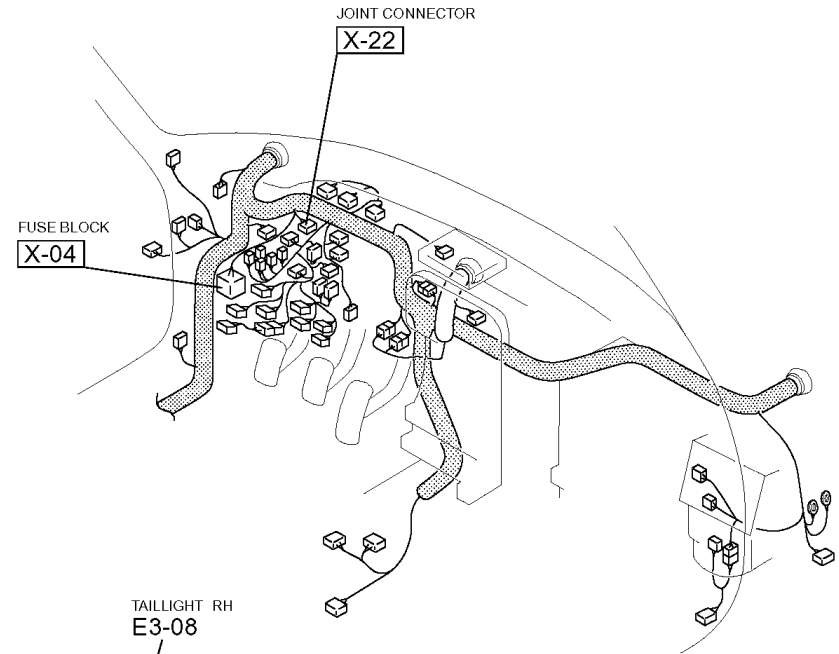
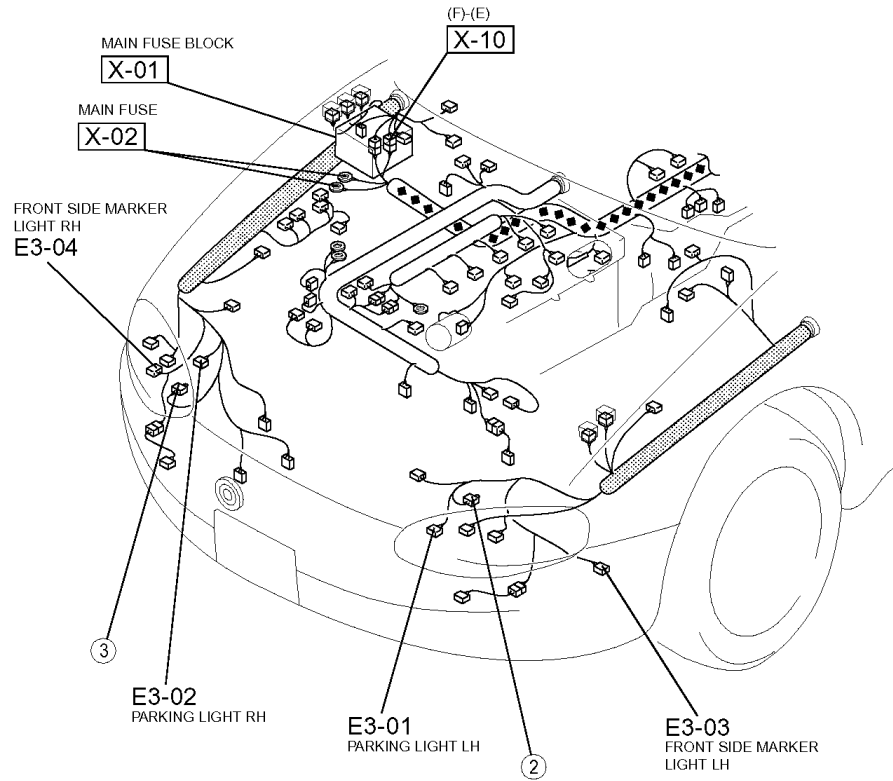

# Front Fog Lights (Option) \ E-4

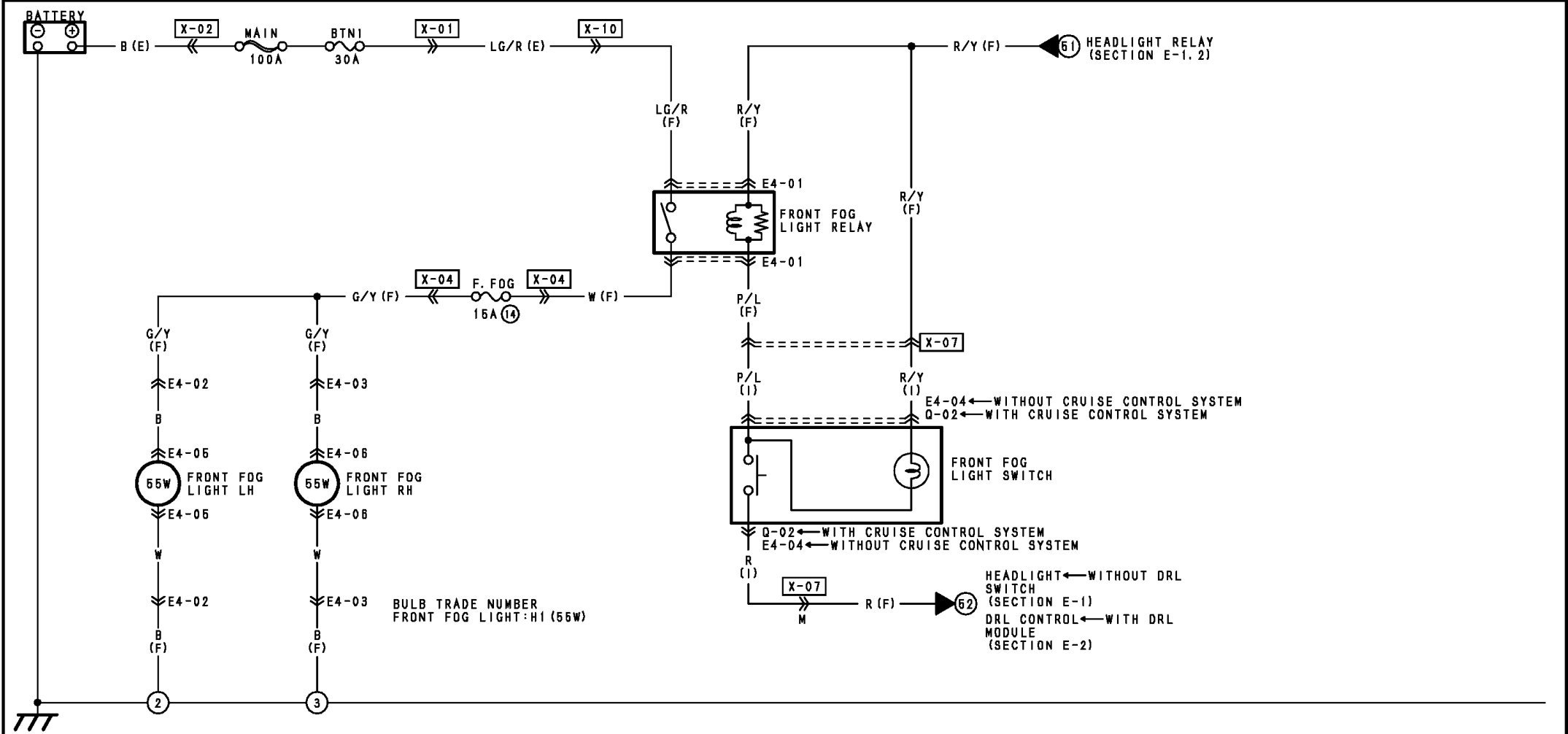

<p><b>E4-01 FRONT FOG LIGHT RELAY (F)</b></p>	<p><b>E4-02 FRONT (F)-SHORT CORD</b></p> <p>(F) (SHORT CORD)</p>		<p><b>E4-03 FRONT (F)-SHORT CORD</b></p> <p>(F) (SHORT CORD)</p>		<p><b>E4-04 FRONT FOG LIGHT SWITCH (I)</b></p> <table border="1" style="margin-left: auto; margin-right: auto;"> <tr> <td>*</td> <td>P/L</td> <td>R/B</td> </tr> <tr> <td>R/Y</td> <td>R</td> <td>GY/R</td> </tr> </table> <p>(WITHOUT CRUISE CONTROL SYSTEM)</p>		*	P/L	R/B	R/Y	R	GY/R				
*	P/L	R/B														
R/Y	R	GY/R														
<p><b>E4-05 FRONT FOG LIGHT LH (SHORT CORD)</b></p>	<p><b>E4-06 FRONT FOG LIGHT RH (SHORT CORD)</b></p>	<p><b>Q-02 FRONT FOG LIGHT SWITCH (I)</b></p> <table border="1" style="margin-left: auto; margin-right: auto;"> <tr> <td>GY/R</td> <td>*</td> <td>⊗</td> <td>*</td> <td>R/B</td> </tr> <tr> <td>R/Y</td> <td>P/L</td> <td>R</td> <td>B/Y</td> <td>W/L</td> <td>B</td> </tr> </table> <p>(WITH CRUISE CONTROL SYSTEM)</p>		GY/R	*	⊗	*	R/B	R/Y	P/L	R	B/Y	W/L	B		
GY/R	*	⊗	*	R/B												
R/Y	P/L	R	B/Y	W/L	B											

HARNESS SYMBOL :  (F)  (E)  (R)

# Front Fog Lights (Option) \ E-4

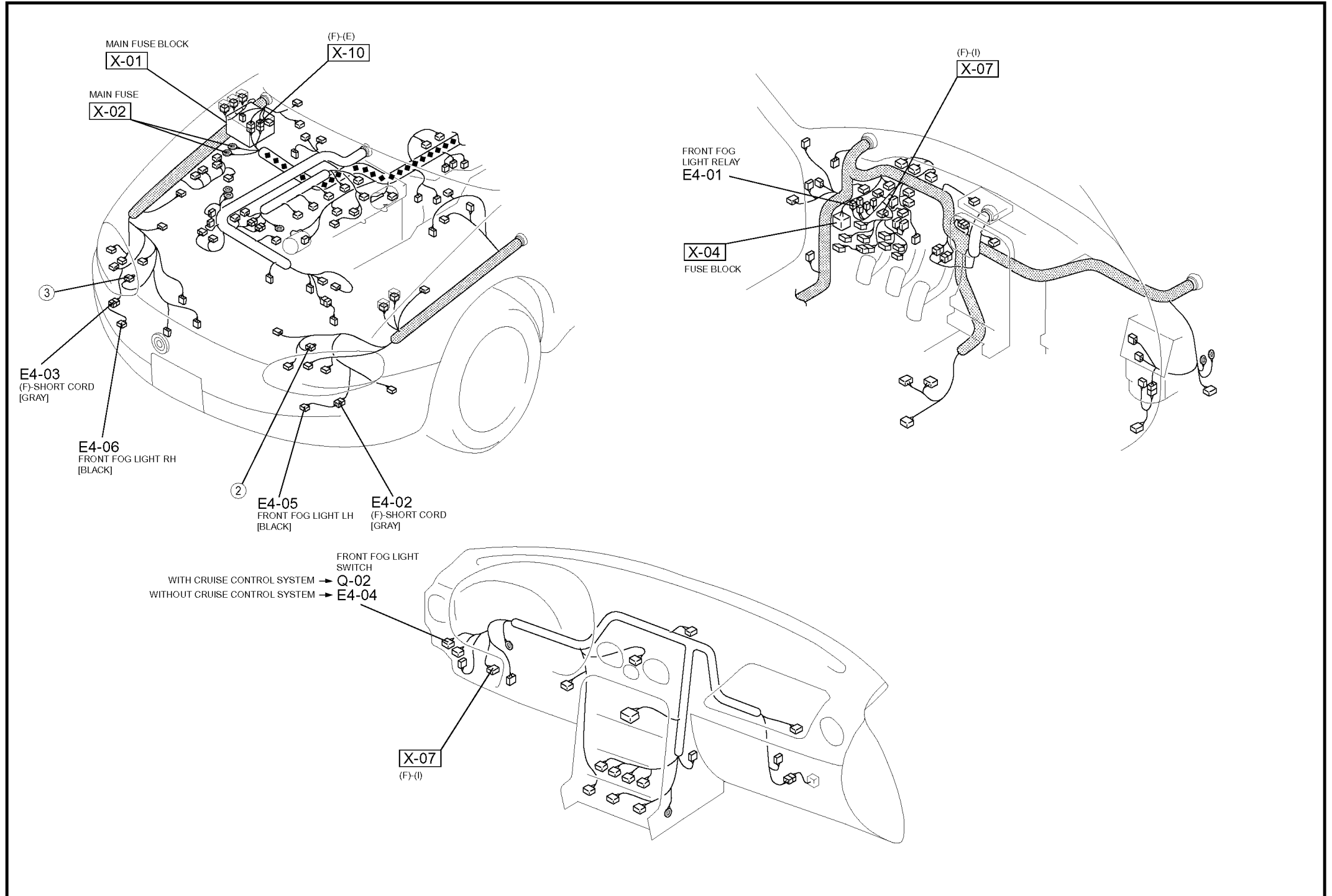

# Turn and Hazzard Warning Lights \ F-1

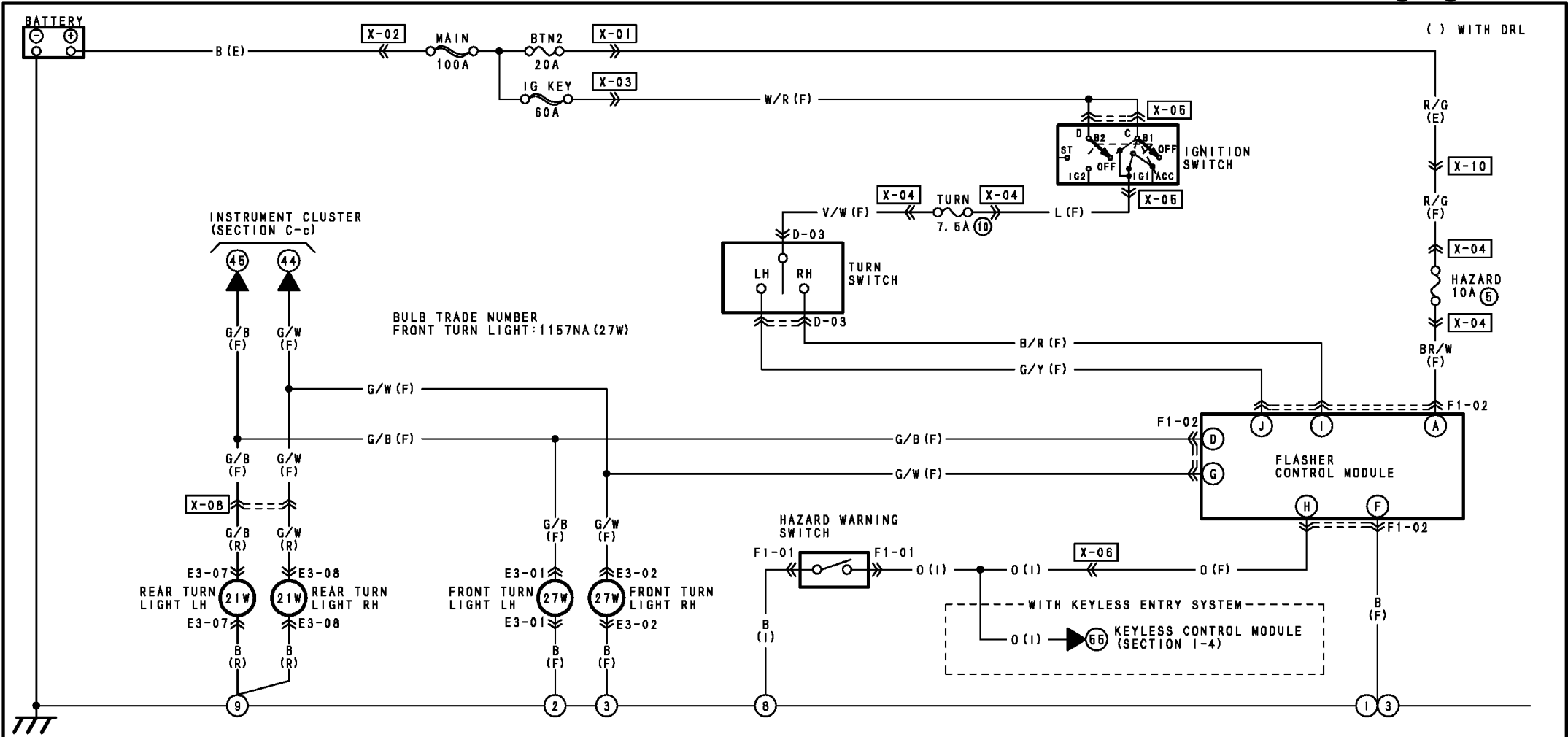

F1-01 HAZARD WARNING SWITCH (I)

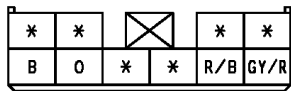

F1-02 FLASHER CONTROL MODULE (F)

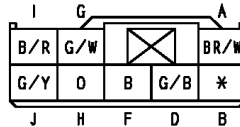

D-03 TURN SWITCH (F)

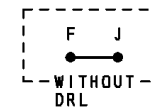

E3-01 FRONT TURN LIGHT LH (F)

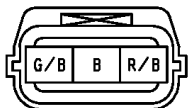

E3-02 FRONT TURN LIGHT RH (F)

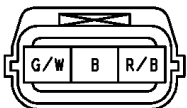

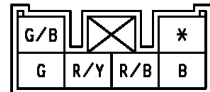

E3-07 REAR TURN LIGHT LH (R)

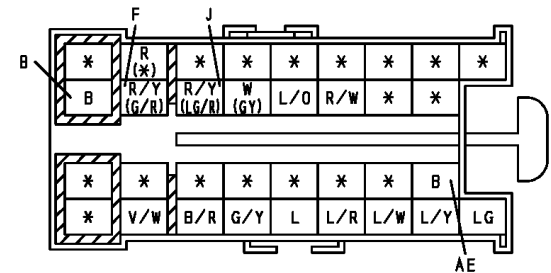

E3-08 REAR TURN LIGHT RH (R)



HARNESS SYMBOL :  (F)  (E)  (R)

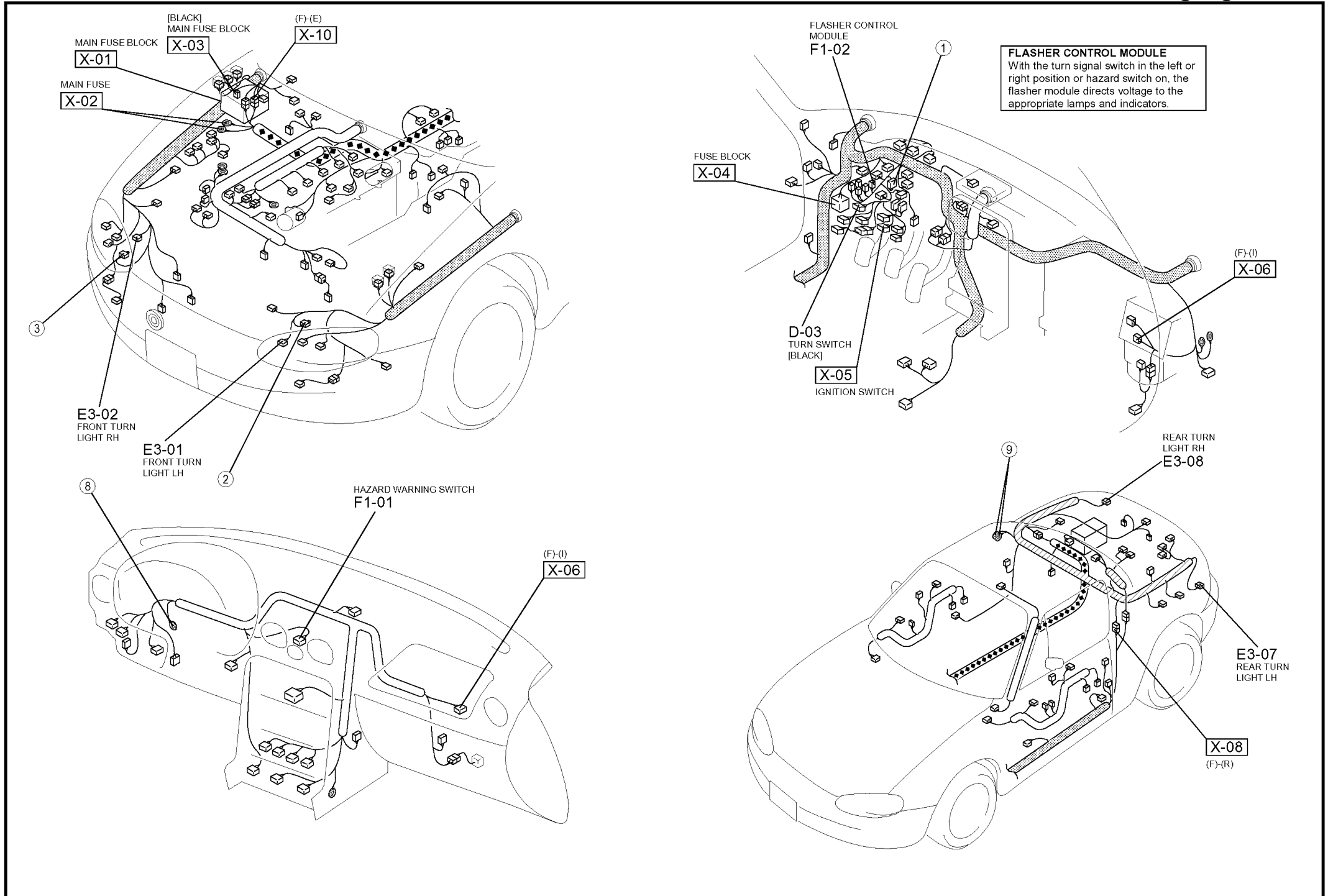

# Turn and Hazzard Warning Lights \ F-1

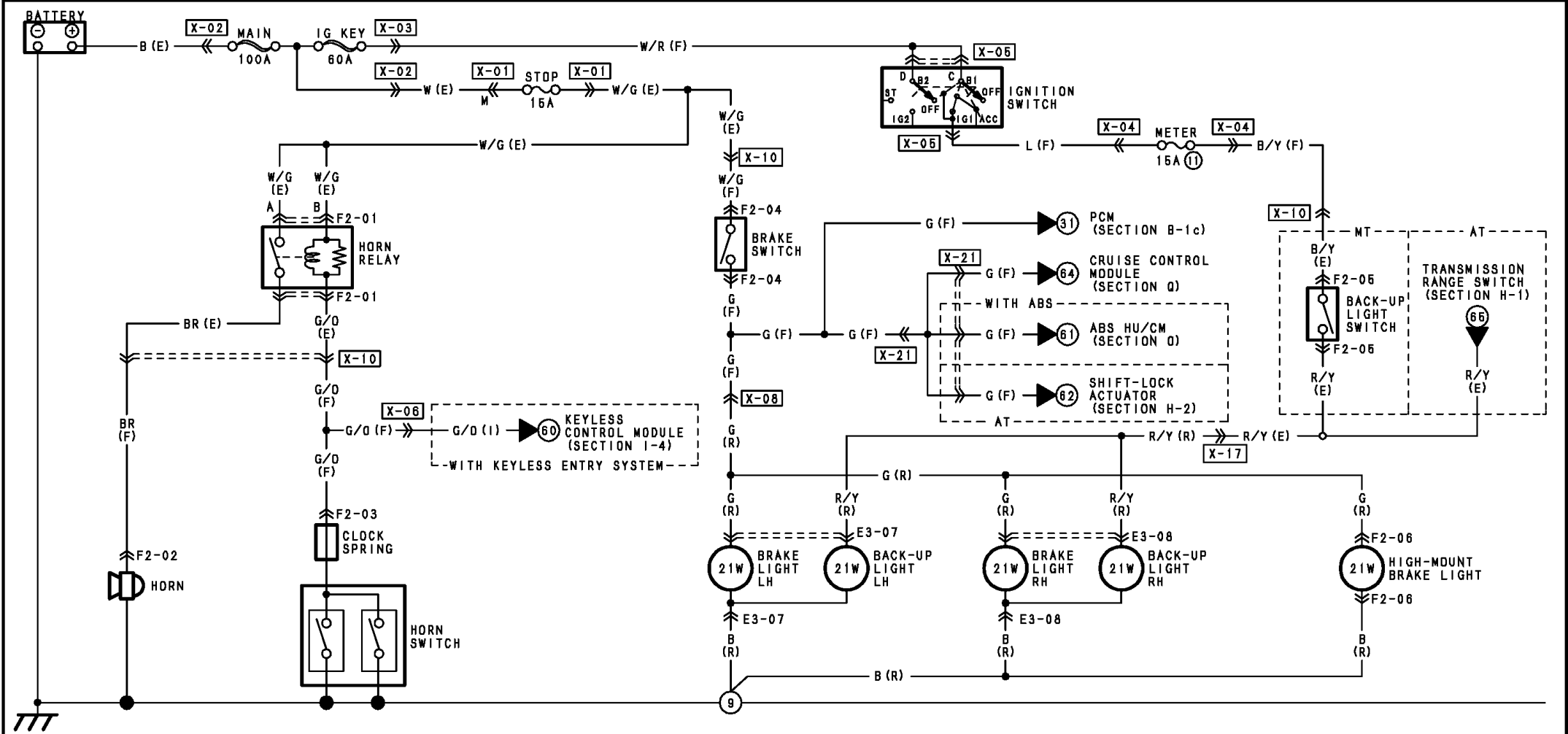

# Back-up Lights \ Brake Lights \ High-Mount Brake Light \ Horn \ F-2



<p>F2-01 HORN RELAY (E)</p> <p>FRONT SIDE</p>	<p>F2-02 HORN (F)</p>	<p>F2-03 HORN SWITCH (F)</p> <p>(CLOCK SPRING)</p>	<p>F2-04 BRAKE SWITCH (F)</p>	<p>F2-05 BACK-UP LIGHT SWITCH (E)</p> <p>(MT)</p>	<p>F2-06 HIGH-MOUNT BRAKE LIGHT (R)</p>
<p>NOTE: THIS IS THE CONNECTOR AS SEEN FROM THE TERMINAL SIDE.</p>	<p>E3-07 BRAKE LIGHT LH / BACK-UP LIGHT LH (R)</p>	<p>E3-08 BRAKE LIGHT RH / BACK-UP LIGHT RH (R)</p>			

HARNESS SYMBOL :  (F)  (E)  (R)

# Back-up Lights \ Brake Lights \ High-Mount Brake Light \ Horn \ F-2

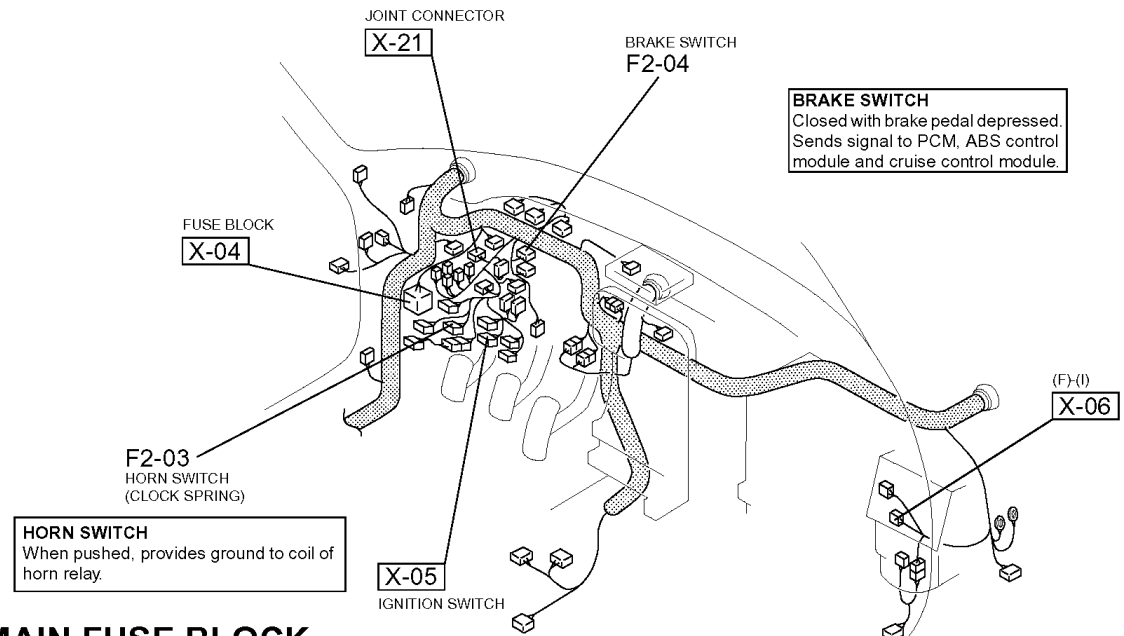
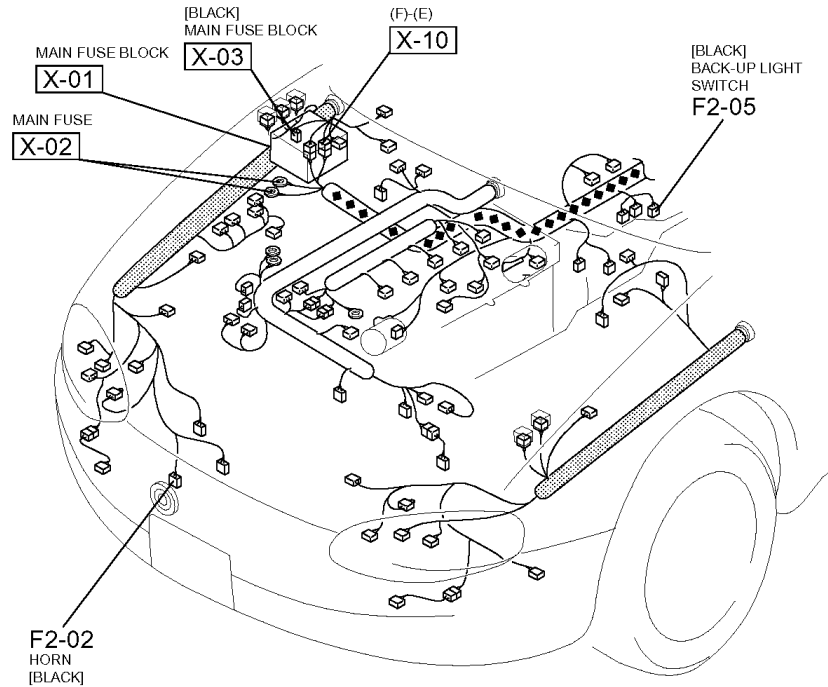

## MAIN FUSE BLOCK

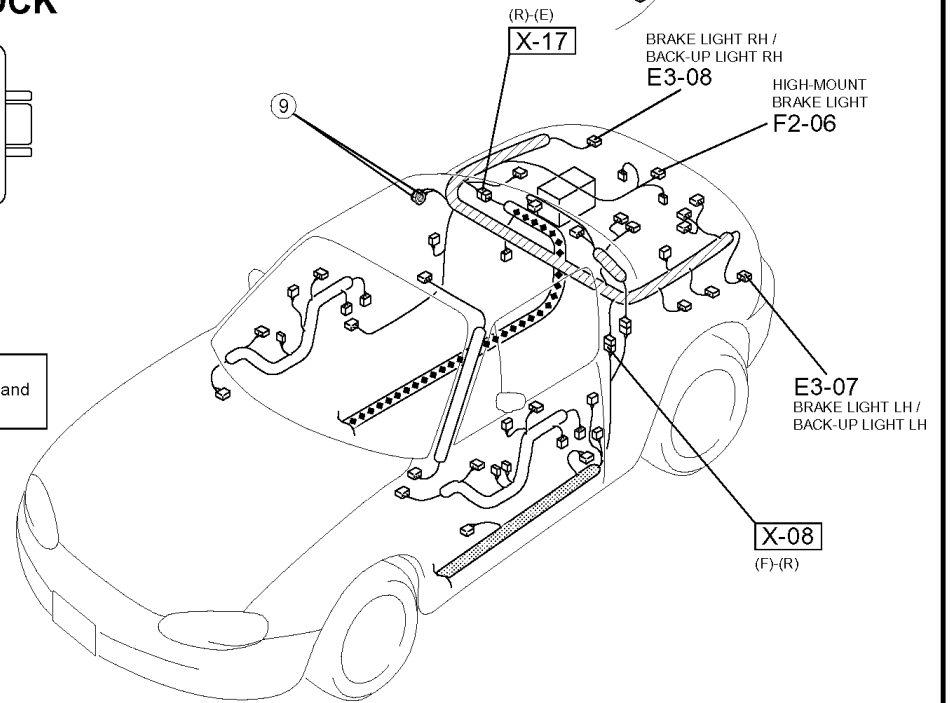
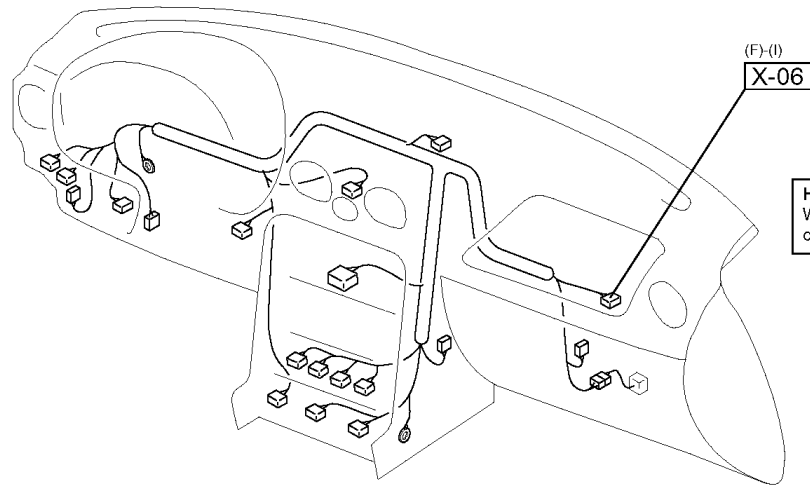
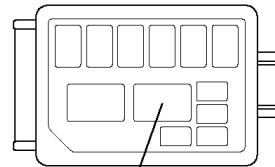

# Condenser Fan System \ Heater and Air Conditioner \ G

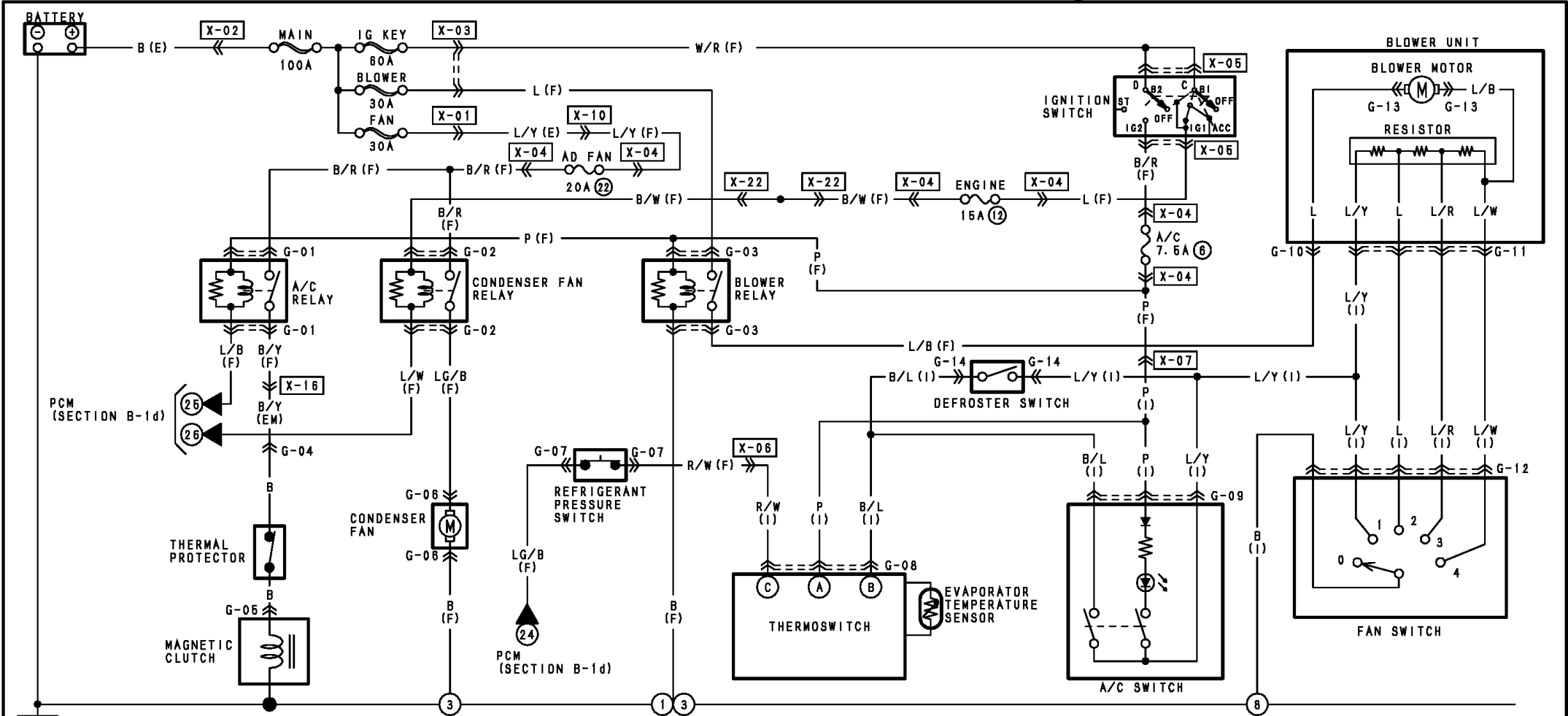

<b>G-01 A/C RELAY (F)</b> 	<b>G-02 CONDENSER FAN RELAY (F)</b> 	<b>G-03 BLOWER RELAY (F)</b> 	<b>G-04 EMISSION (EM) - THERMAL PROTECTOR</b> 		<b>G-05 MAGNETIC CLUTCH (THERMAL PROTECTOR)</b> 	<b>G-06 CONDENSER FAN (F)</b> 
<b>G-07 REFRIGERANT PRESSURE SWITCH (F)</b> 	<b>G-08 THERMOSWITCH (I)</b> 	<b>G-09 A/C SWITCH (I)</b> 		<b>G-10 FRONT (F) - SHORT CORD</b> 	<b>G-11 INSTRUMENT PANEL (I) - SHORT CORD</b> 	
<b>G-12 FAN SWITCH (I)</b> 		<b>G-13 BLOWER MOTOR (SHORT CORD)</b> 	<b>G-14 DEFROSTER SWITCH (I)</b> 			



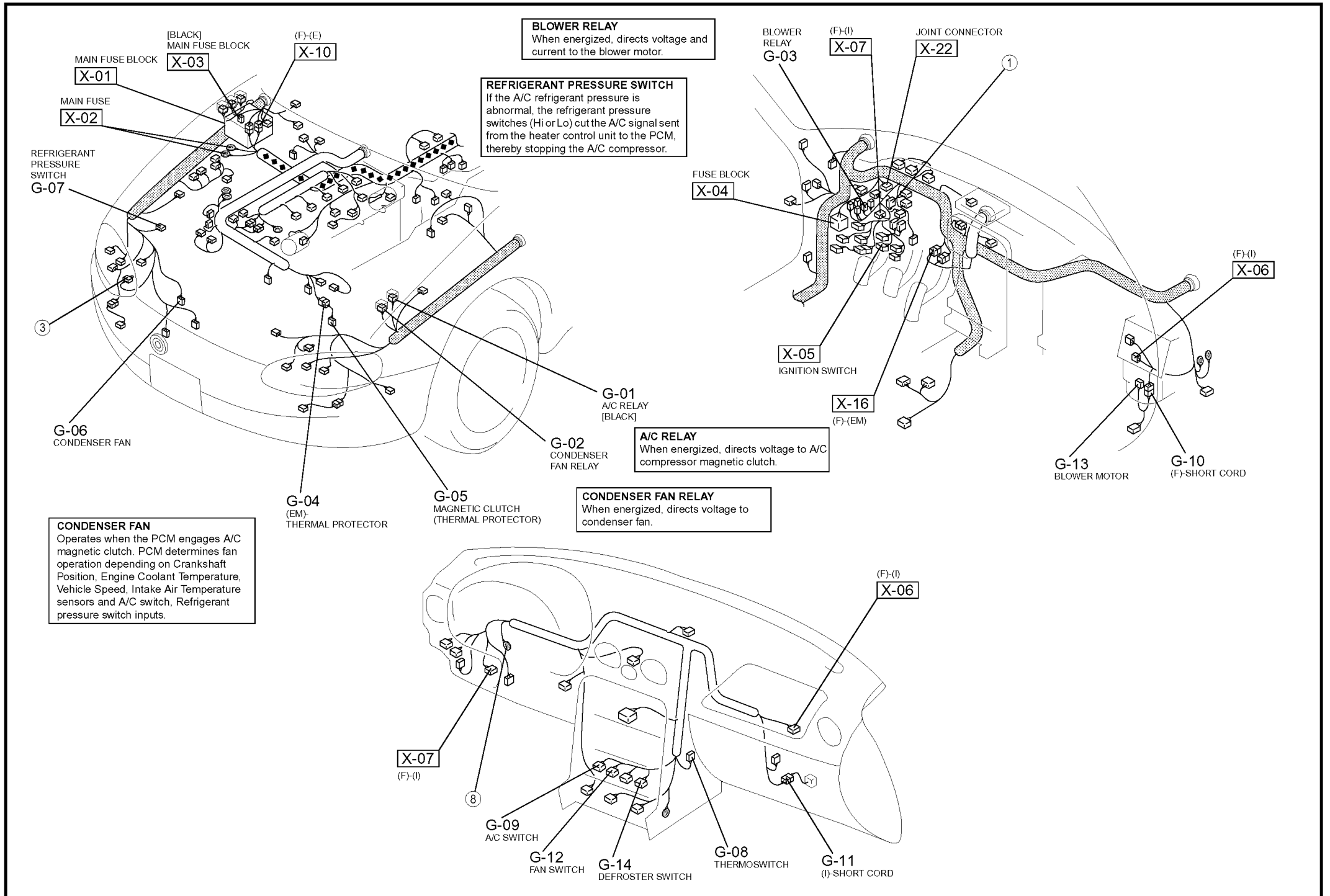

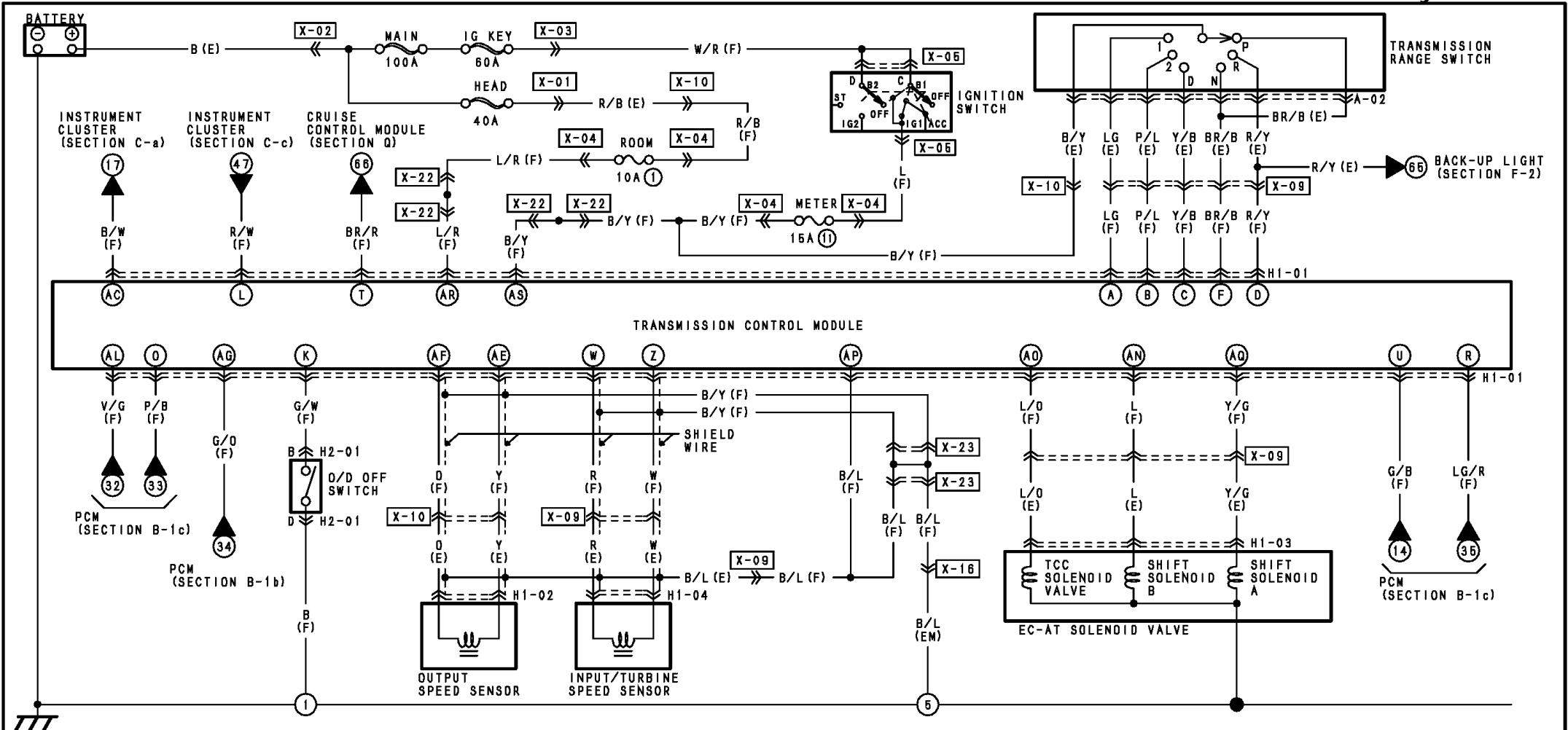

H1-01 TRANSMISSION CONTROL MODULE (F)

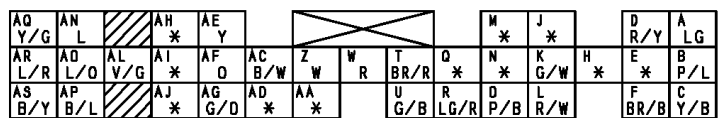

H1-02 OUTPUT SPEED SENSOR (E)



H1-03 EC-AT SOLENOID VALVE (E)

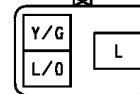

H1-04 INPUT/TURBINE SPEED SENSOR (E)



A-02 TRANSMISSION RANGE SWITCH (E)

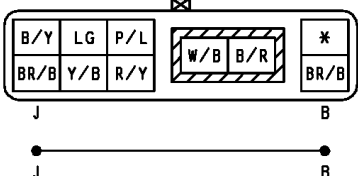

H2-01 D/D OFF SWITCH (F)

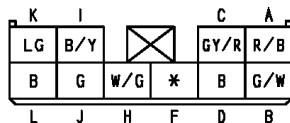

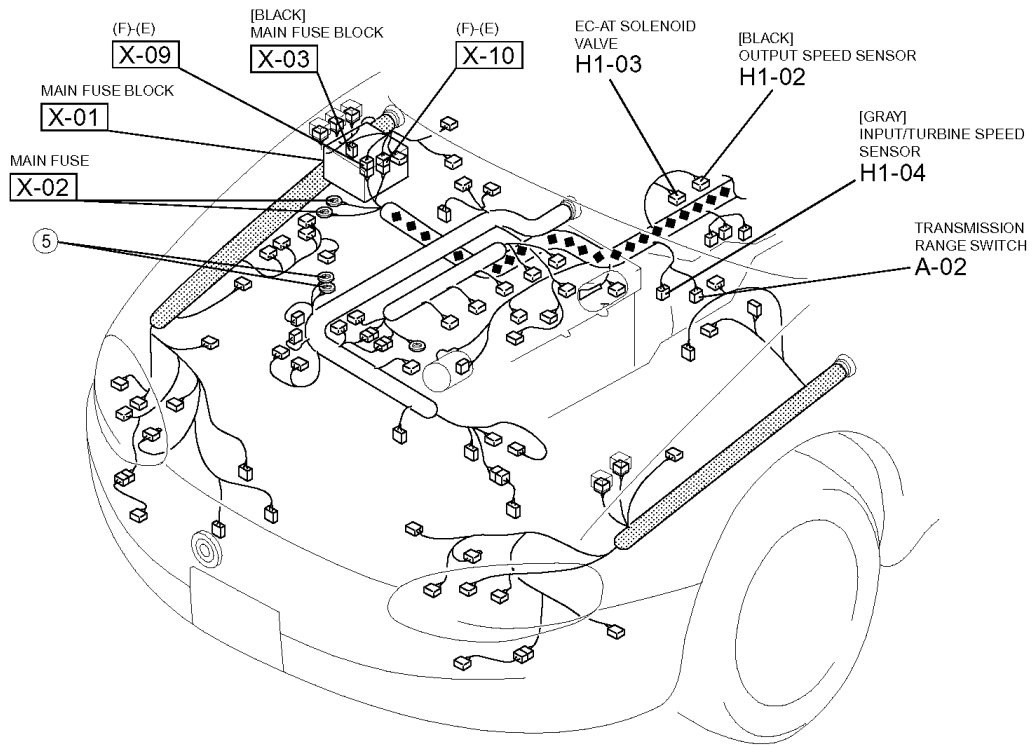

**INPUT/TURBINE SPEED SENSOR**  
 The frequency from this sensor supplies the PCM with turbine shaft speed signal. This signal is used in determining line pressure and torque converter engagement schedules.

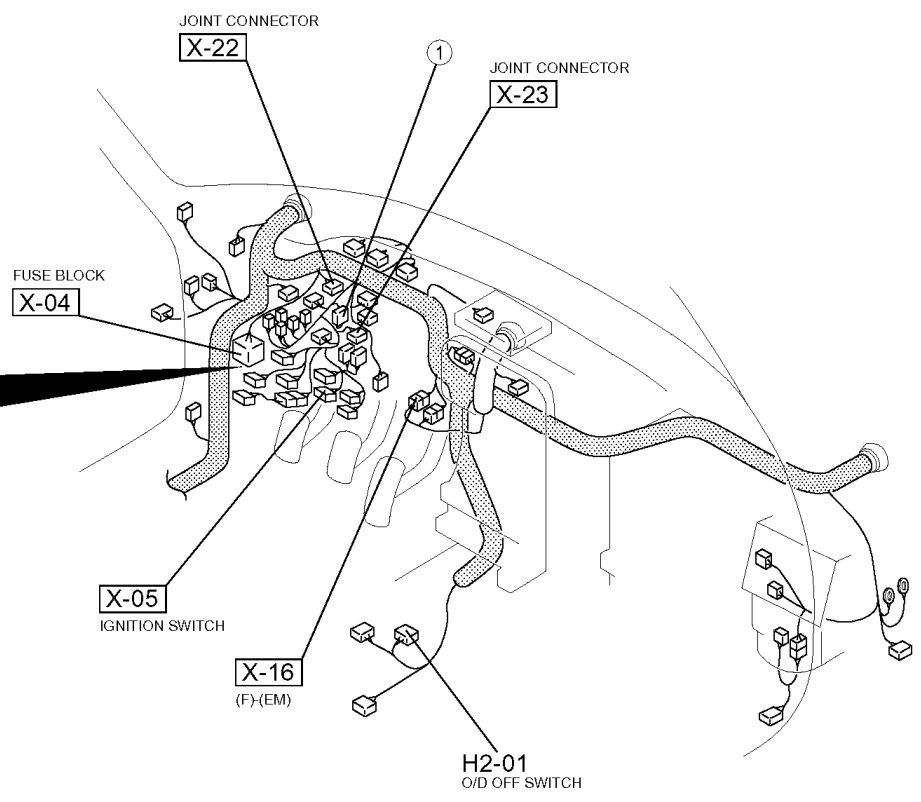
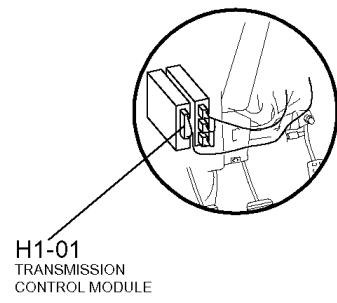

# Key Interlock System \ Shift-Lock System \ H-2

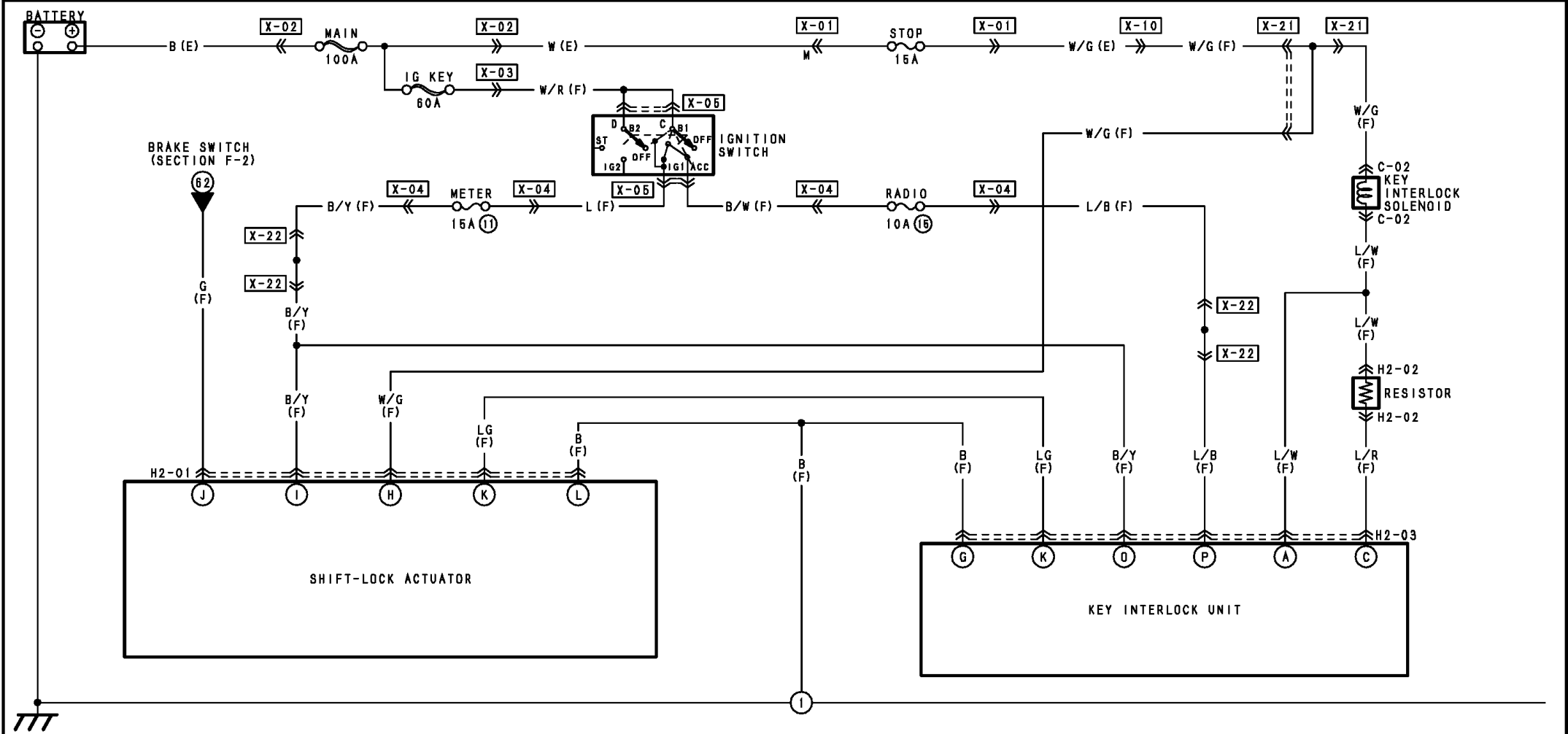

H2-01 SHIFT-LOCK ACTUATOR (F)

	K	I				C	A
	LG	B/Y				GY/R	R/B
	B	G	W/G	*		B	G/W
	L	J	H	F	D	B	

H2-02 RESISTOR (F)



	*	L/R	L/W
--	---	-----	-----

C-02 KEY INTERLOCK SOLENOID (F)

	W/G	L/R
	L/W	L/O

H2-03 KEY INTERLOCK UNIT (F)

	O	M	K	I	G	E	C	A
	B/Y	*	LG	*	B	*	L/R	L/W
	L/B	*	*	*	*	*	*	*
	P	N	L	J	H	F	D	B

HARNESS SYMBOL :  (F)  (E)  (R)

# Key Interlock System \ Shift-Lock System \ H-2

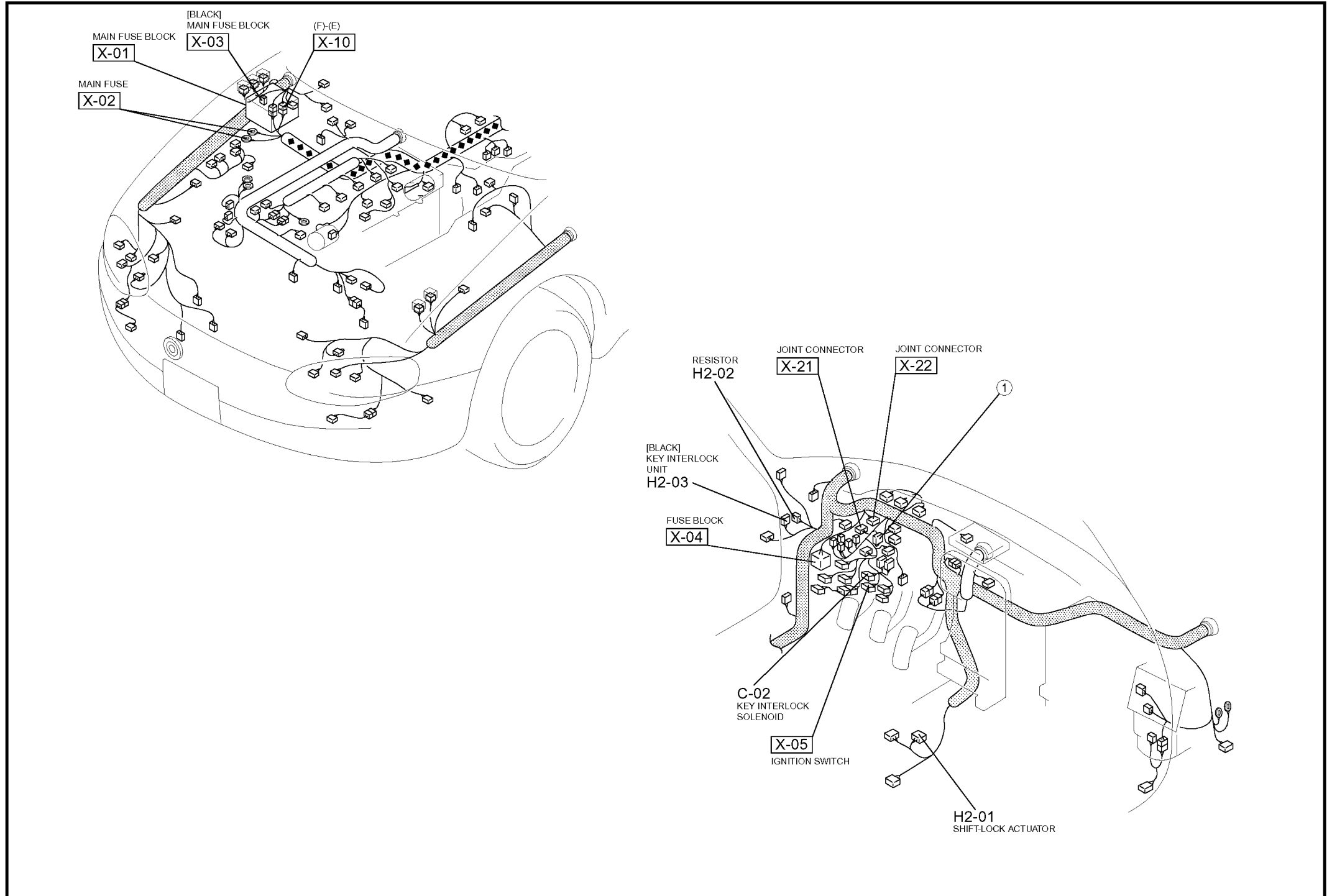

# Illumination Lights \ I-1

< > BOSE AUDIO

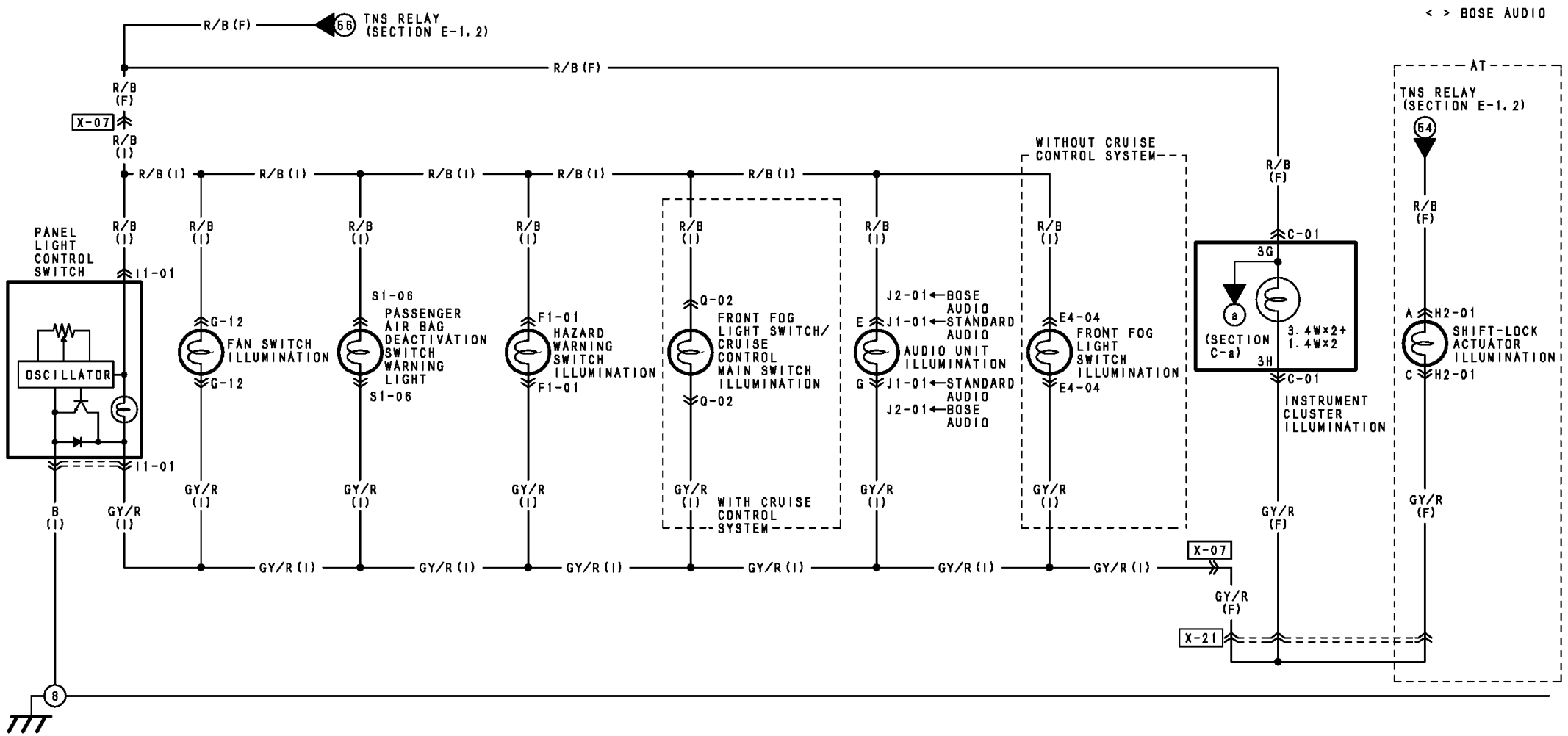

<p><b>11-01 PANEL LIGHT CONTROL SWITCH (1)</b></p>	<p><b>C-01 INSTRUMENT CLUSTER ILLUMINATION (F)</b></p> <table border="1" style="margin: auto;"> <tr><td>B</td><td>G/W</td><td>GY/R</td><td>R/B</td><td>L/O</td><td>Y/R</td><td>W/G</td><td>L/Y</td><td>BR/R</td><td>G/B</td></tr> </table> <p>3J 3I 3H 3G 3F 3E 3D 3C 3B 3A</p>	B	G/W	GY/R	R/B	L/O	Y/R	W/G	L/Y	BR/R	G/B	<p><b>E4-04 FRONT FOG LIGHT SWITCH ILLUMINATION (1)</b></p> <table border="1" style="margin: auto;"> <tr><td>*</td><td>P/L</td><td>R/B</td></tr> <tr><td>R/Y</td><td>R</td><td>GY/R</td></tr> </table> <p>(WITHOUT CRUISE CONTROL SYSTEM)</p>	*	P/L	R/B	R/Y	R	GY/R	<p><b>F1-01 HAZARD WARNING SWITCH ILLUMINATION (1)</b></p> <table border="1" style="margin: auto;"> <tr><td>*</td><td>*</td><td></td><td>*</td><td>*</td></tr> <tr><td>B</td><td>O</td><td>*</td><td>*</td><td>R/B</td><td>GY/R</td></tr> </table>	*	*		*	*	B	O	*	*	R/B	GY/R
B	G/W	GY/R	R/B	L/O	Y/R	W/G	L/Y	BR/R	G/B																					
*	P/L	R/B																												
R/Y	R	GY/R																												
*	*		*	*																										
B	O	*	*	R/B	GY/R																									
<p><b>G-12 FAN SWITCH ILLUMINATION (1)</b></p> <table border="1" style="margin: auto;"> <tr><td>L</td><td>L/Y</td><td></td><td>*</td><td>GY/R</td><td>R/B</td></tr> <tr><td>L/R</td><td>L/W</td><td></td><td></td><td>B</td><td></td></tr> </table>	L	L/Y		*	GY/R	R/B	L/R	L/W			B		<p><b>H2-01 SHIFT-LOCK ACTUATOR ILLUMINATION (F)</b></p> <table border="1" style="margin: auto;"> <tr><td>LG</td><td>B/Y</td><td></td><td>GY/R</td><td>R/B</td></tr> <tr><td>B</td><td>G</td><td>W/G</td><td>*</td><td>B</td><td>G/W</td></tr> </table> <p>L J H F D B (AT)</p>	LG	B/Y		GY/R	R/B	B	G	W/G	*	B	G/W	<p><b>J1-01 AUDIO UNIT ILLUMINATION (1)</b></p> <p>J2-01 ← STANDARD AUDIO</p> <p>J2-01 ← BOSE AUDIO</p>					
L	L/Y		*	GY/R	R/B																									
L/R	L/W			B																										
LG	B/Y		GY/R	R/B																										
B	G	W/G	*	B	G/W																									
<p><b>Q-02 FRONT FOG LIGHT SWITCH/CRUISE CONTROL MAIN SWITCH ILLUMINATION (1)</b></p> <table border="1" style="margin: auto;"> <tr><td>GY/R</td><td>*</td><td></td><td>*</td><td>R/B</td></tr> <tr><td>R/Y</td><td>P/L</td><td>R</td><td>B/Y</td><td>W/L</td><td>B</td></tr> </table> <p>(WITH CRUISE CONTROL SYSTEM)</p>	GY/R	*		*	R/B	R/Y	P/L	R	B/Y	W/L	B	<p><b>S1-06 PASSENGER AIR BAG DEACTIVATION SWITCH WARNING LIGHT (1)</b></p> <table border="1" style="margin: auto;"> <tr><td>GY/R</td><td>B/R</td><td>*</td><td>B/Y</td></tr> <tr><td>LG</td><td>*</td><td>W</td><td>R/B</td></tr> </table>	GY/R	B/R	*	B/Y	LG	*	W	R/B										
GY/R	*		*	R/B																										
R/Y	P/L	R	B/Y	W/L	B																									
GY/R	B/R	*	B/Y																											
LG	*	W	R/B																											

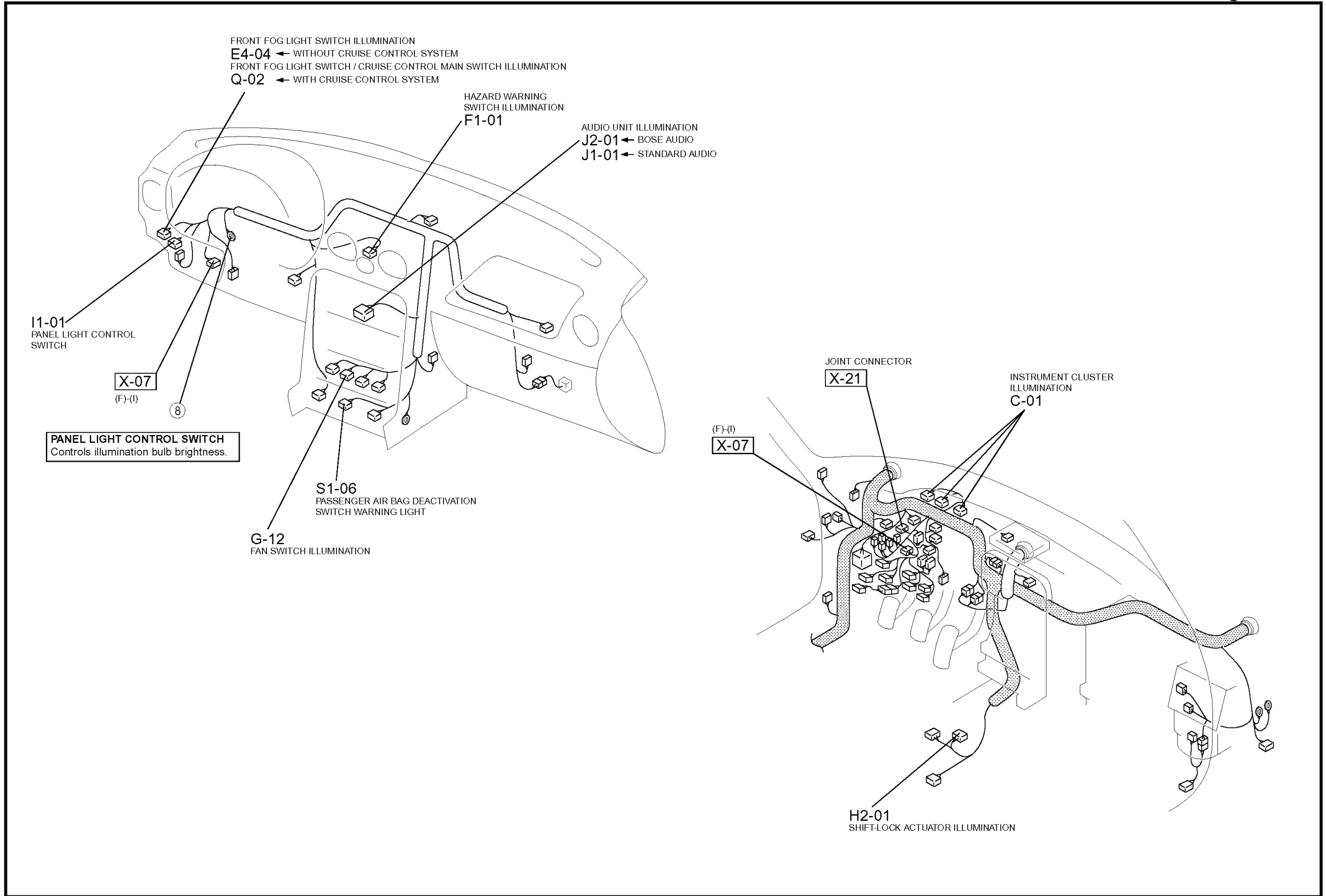

# Cigarette Lighter \ Rear Window Defroster \ I-2

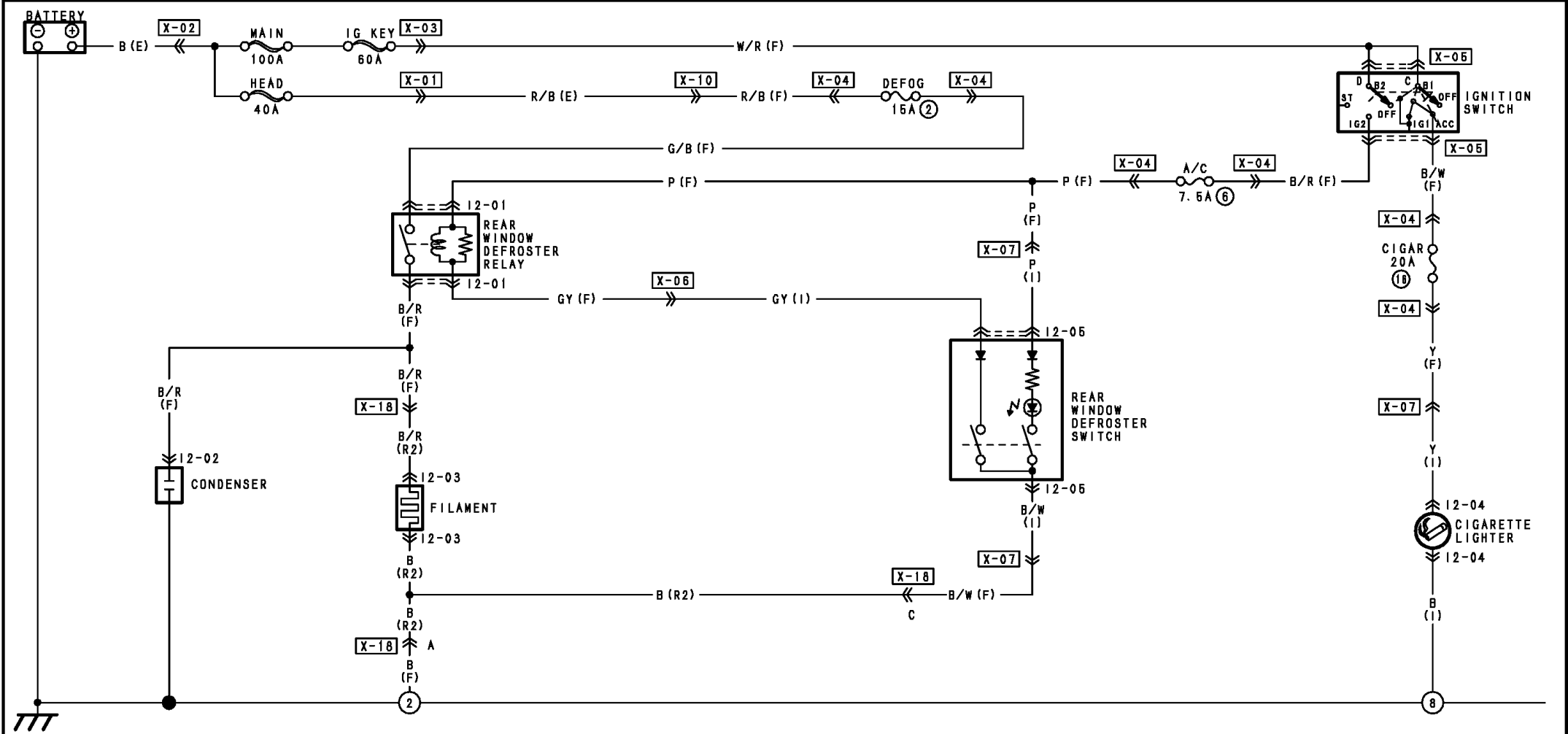

<p>12-01 REAR WINDOW DEFROSTER RELAY (F)</p>	<p>12-02 CONDENSER (F)</p>	<p>12-03 FILAMENT (R2)</p>	<p>12-04 CIGARETTE LIGHTER (I)</p>	<p>12-05 REAR WINDOW DEFROSTER SWITCH (I)</p>		



HARNESS SYMBOL :  (F)  (E)  (R)

# Cigarette Lighter \ Rear Window Defroster \ I-2

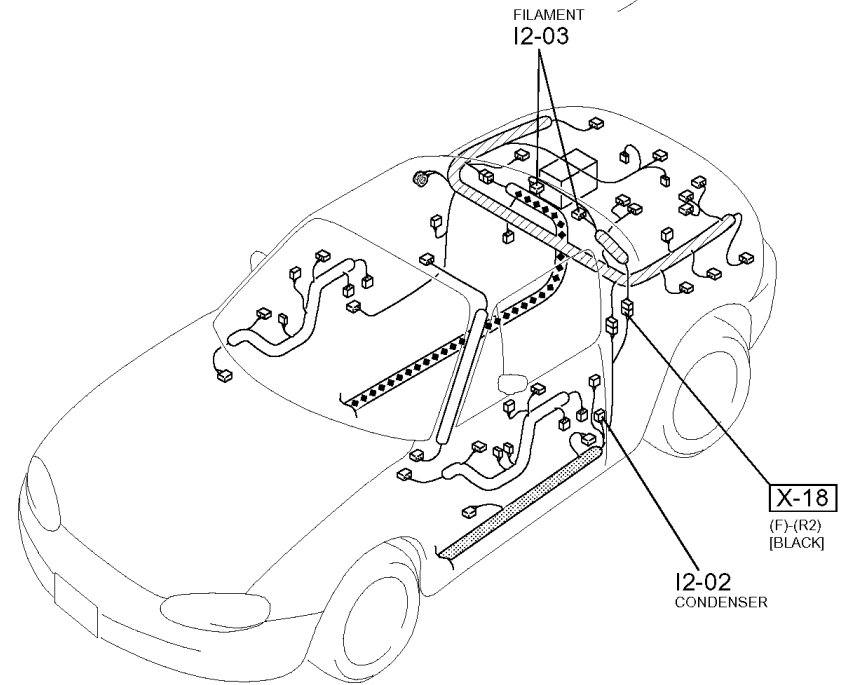
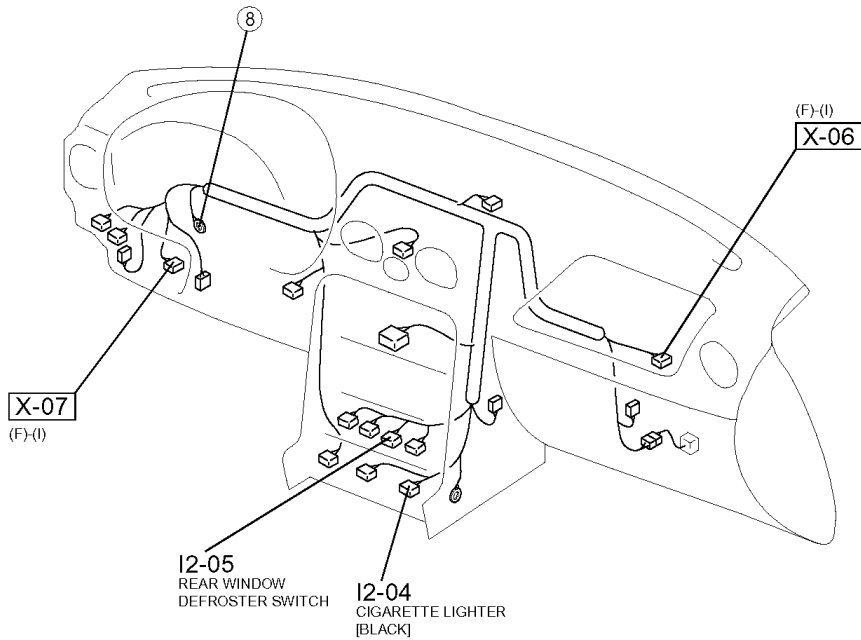
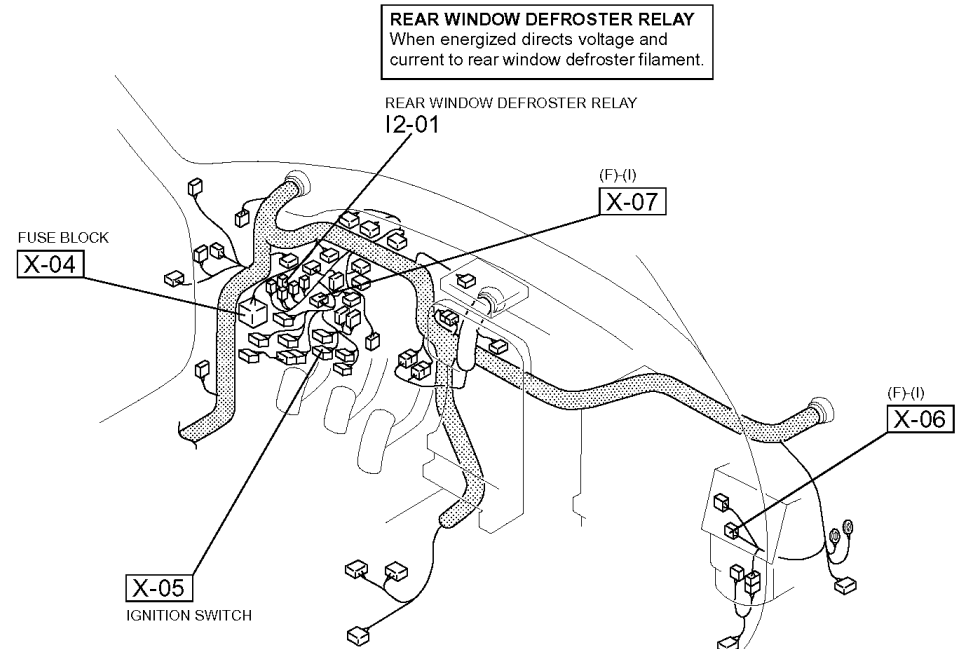
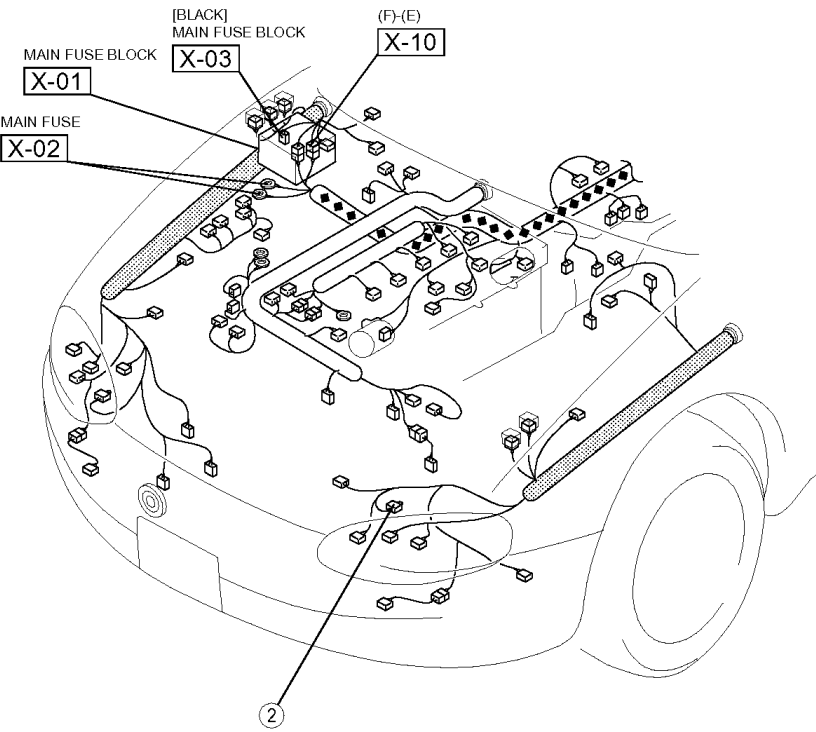

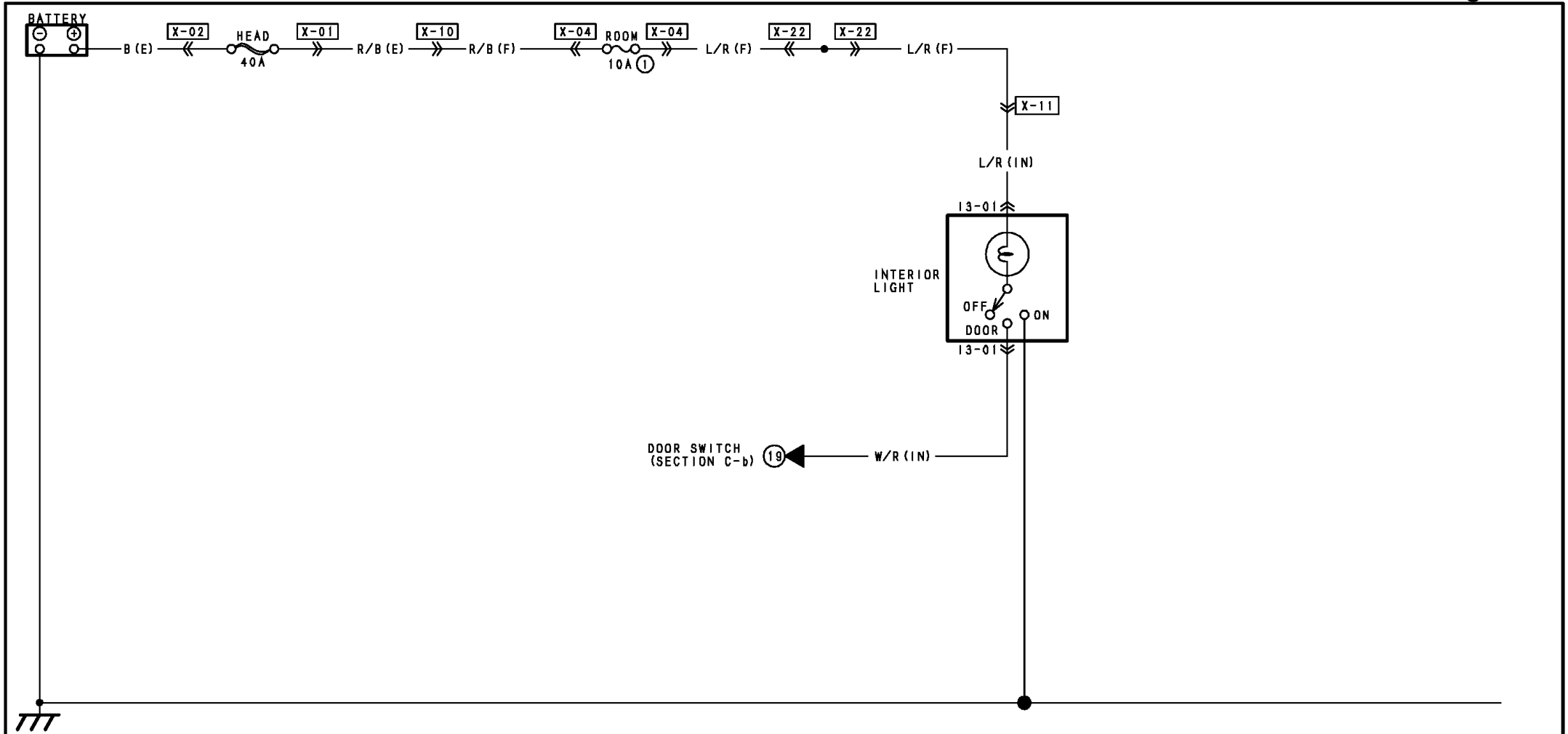

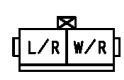
<p>13-01 INTERIOR LIGHT (IN)</p> 					

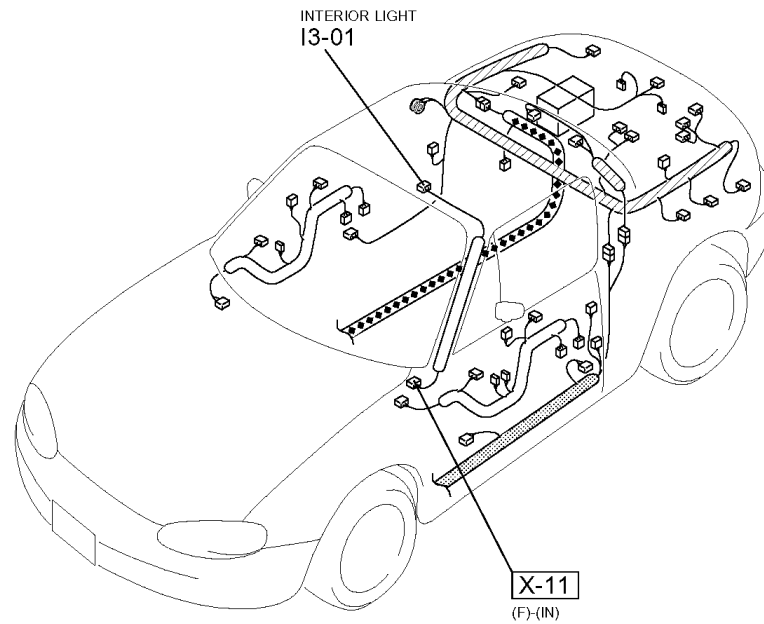
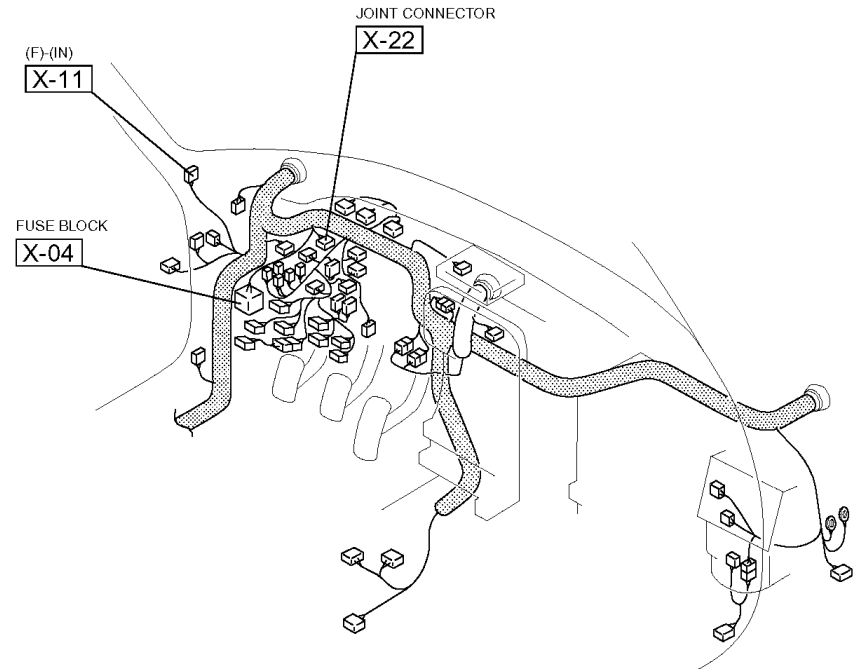
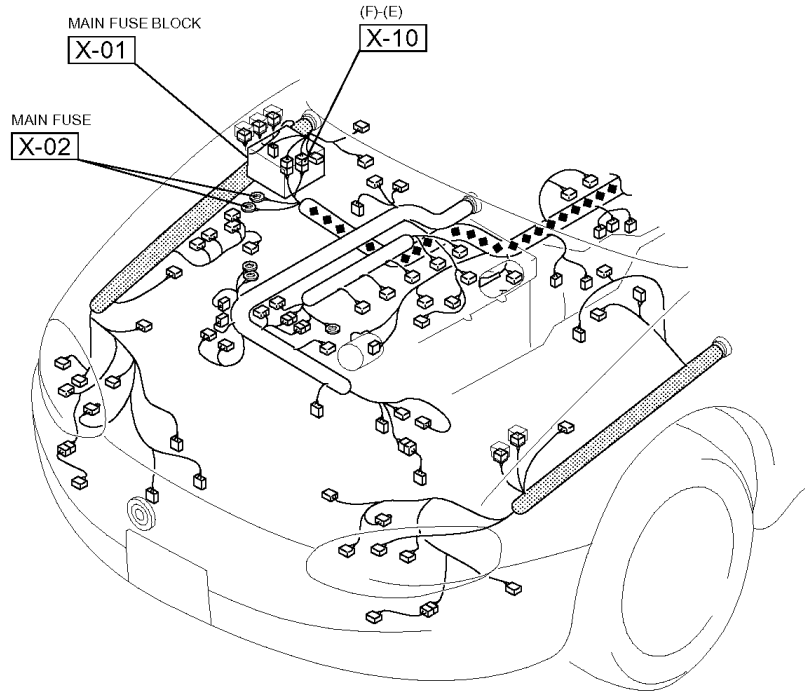

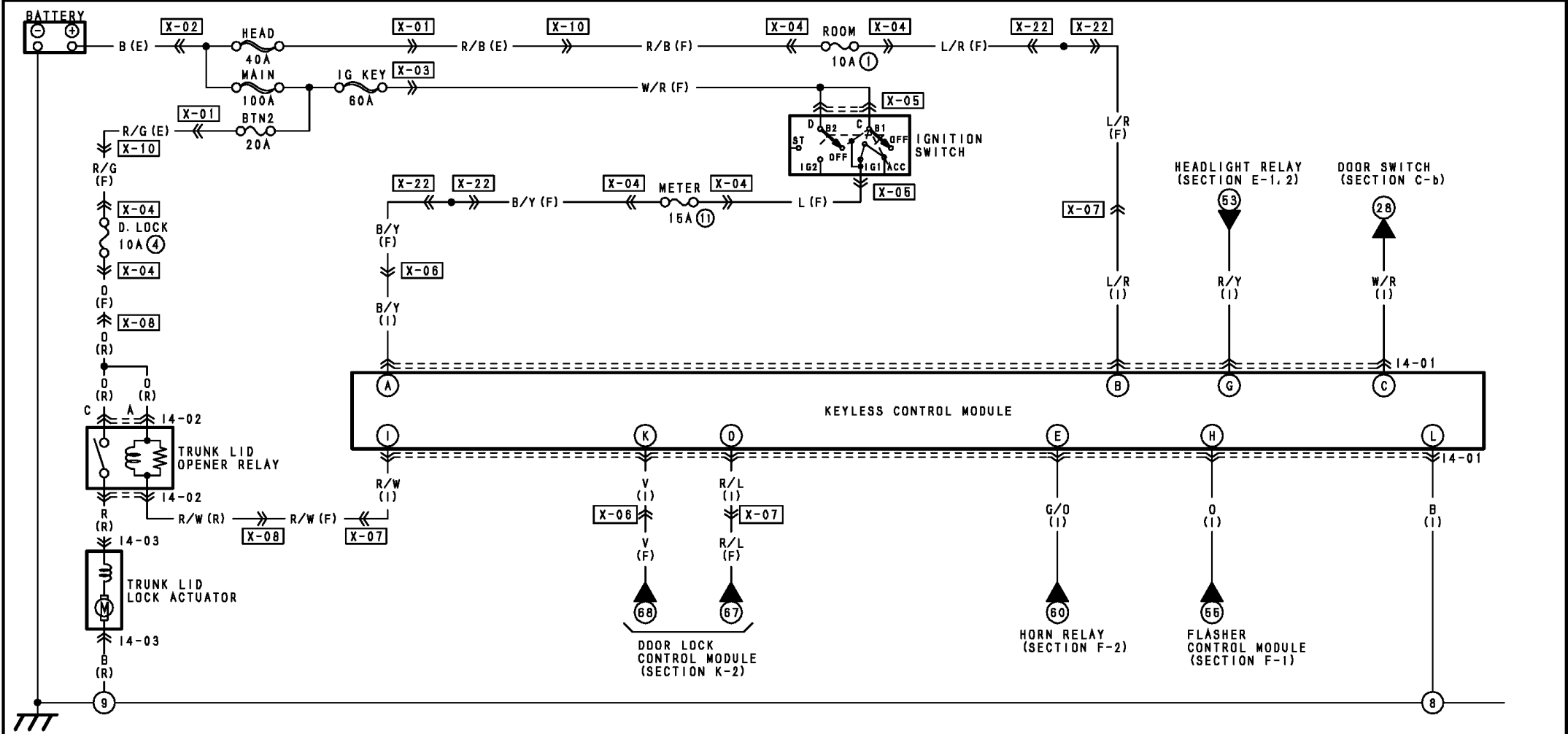

14-01 KEYLESS CONTROL MODULE (I)

	D	M	K	I	G	E	C	A
R/L	*	V	R/W	R/Y	G/D	W/R	B/Y	
*	*	B	*	D	*	*	L/R	
P	N	L	J	H	F	D	B	

14-02 TRUNK LID OPENER RELAY (R)

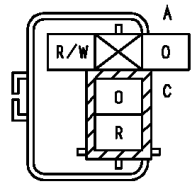

14-03 TRUNK LID LOCK ACTUATOR (R)

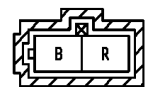

HARNESS SYMBOL :  (F)  (E)  (R)

# Keyless Entry System \ I-4

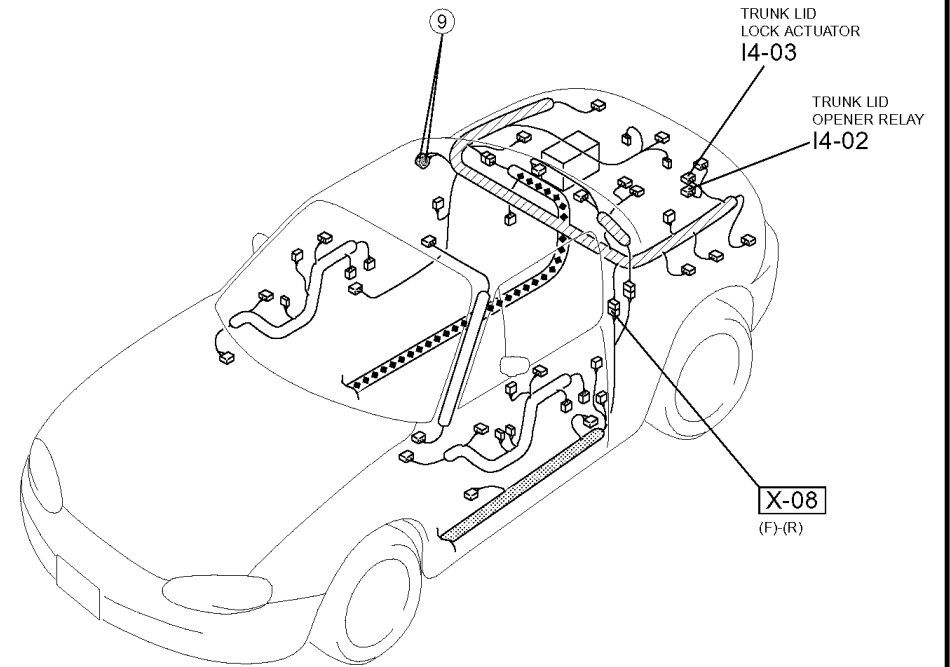
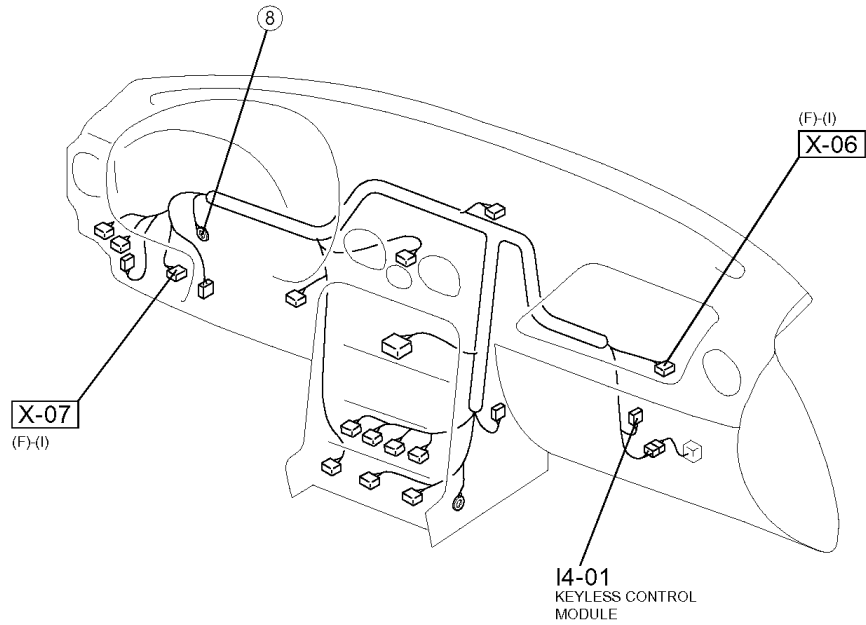
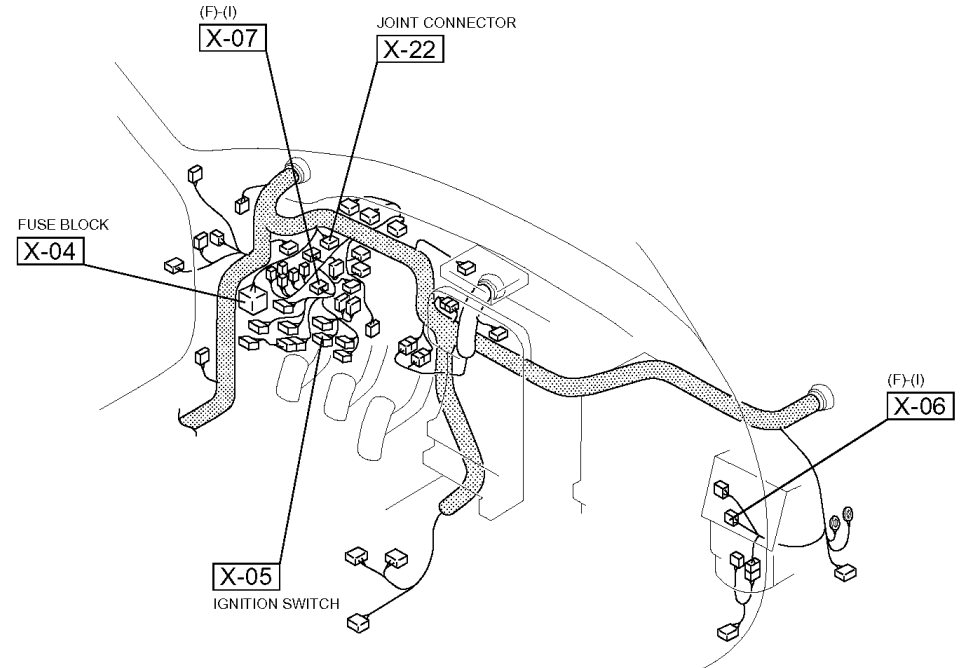
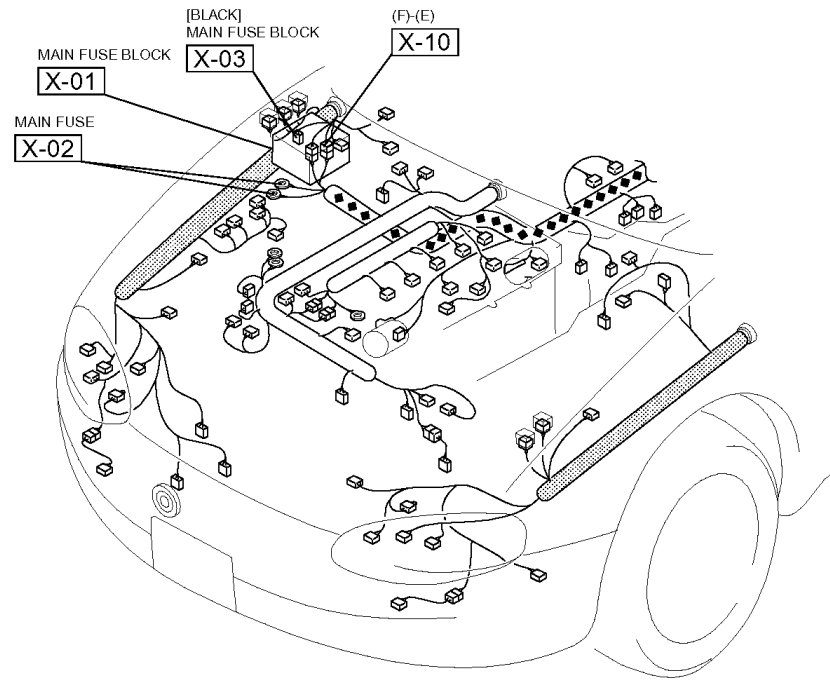

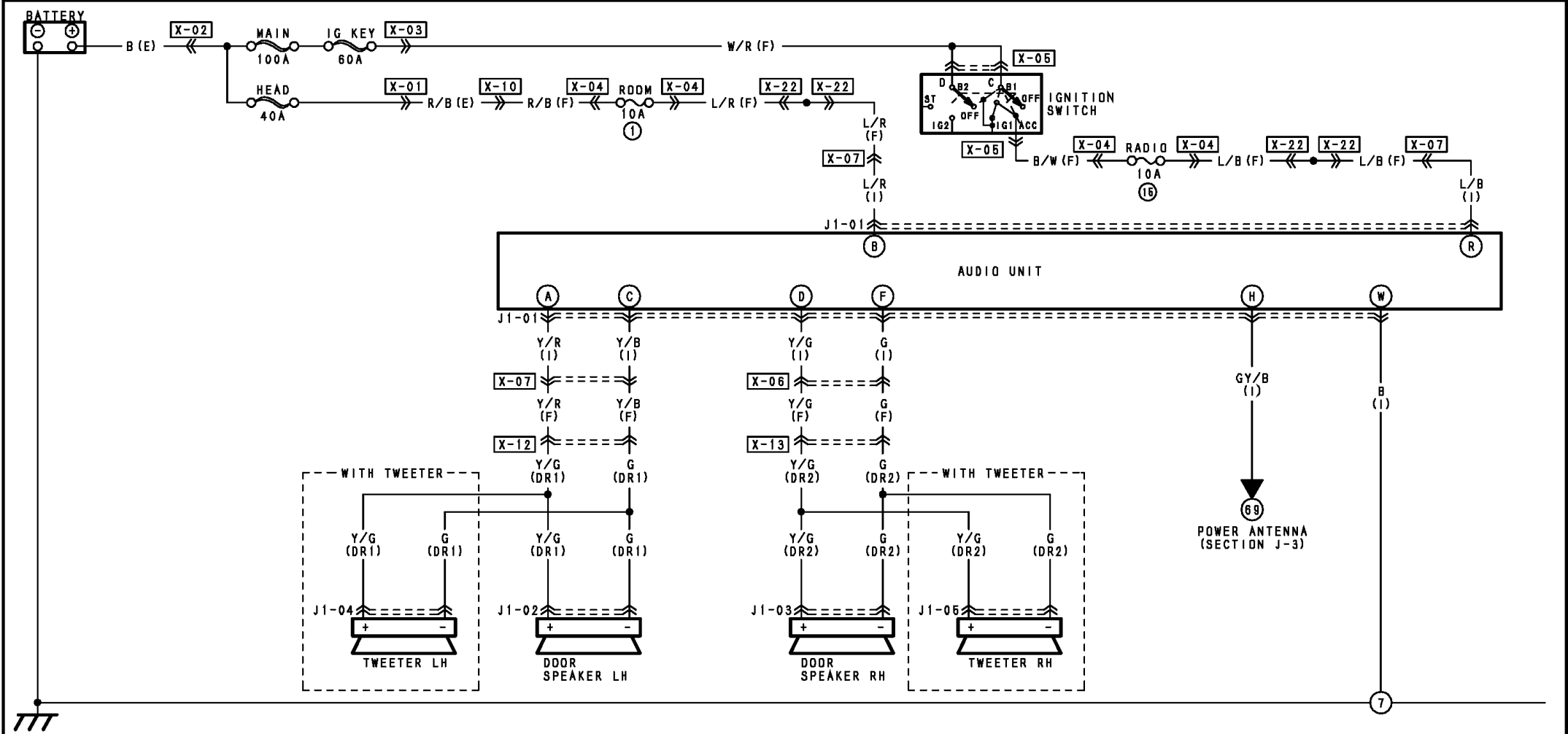

J1-01 AUDIO UNIT (1)

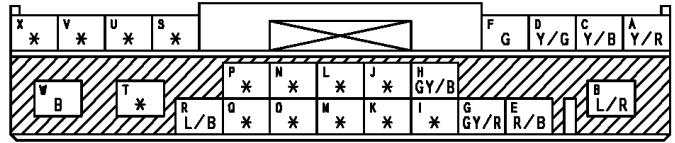

J1-02 DOOR SPEAKER LH (DR1)



J1-03 DOOR SPEAKER RH (DR2)



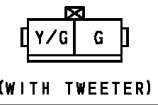

J1-04 TWEETER LH (DR1)

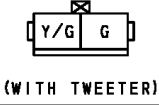

J1-05 TWEETER RH (DR2)



HARNES SYMBOL :  (F)  (E)  (R)

# Audio System (Normal Audio) \ J-1

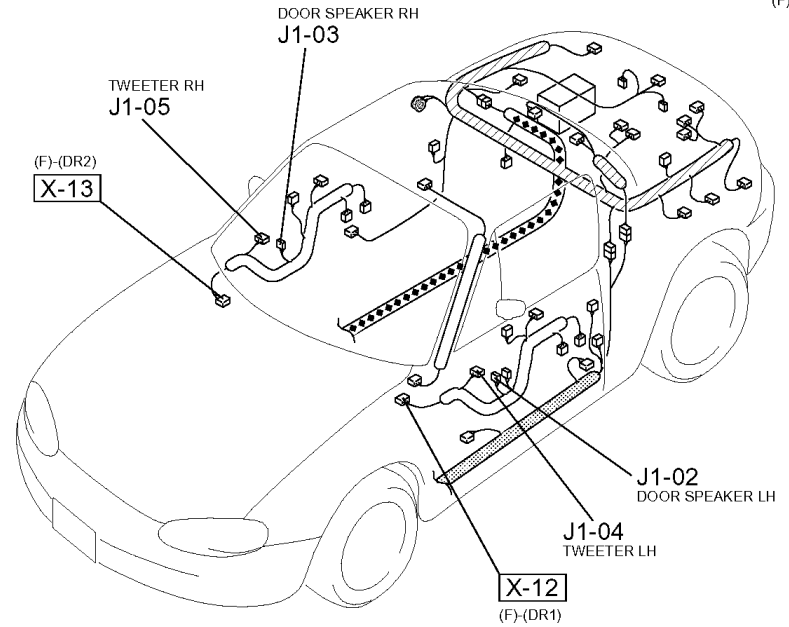
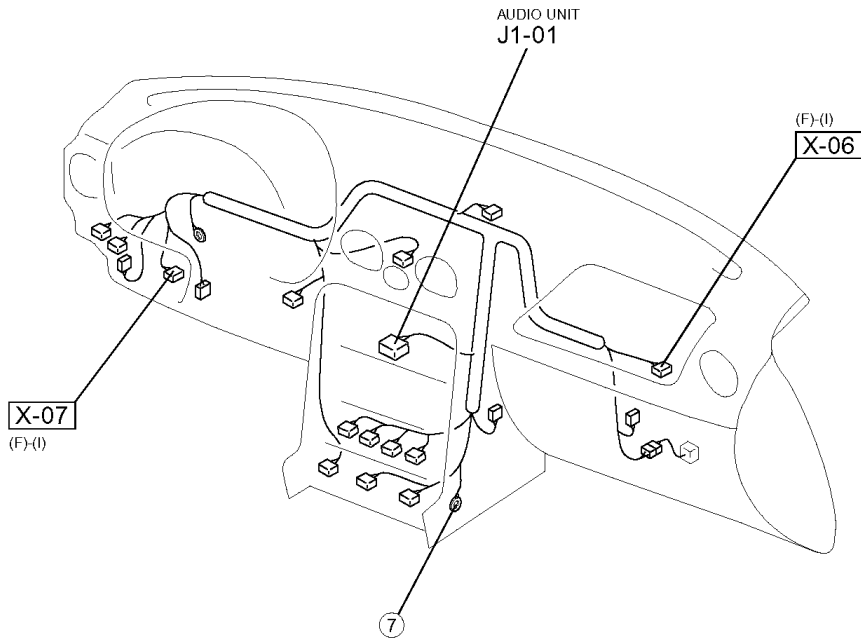
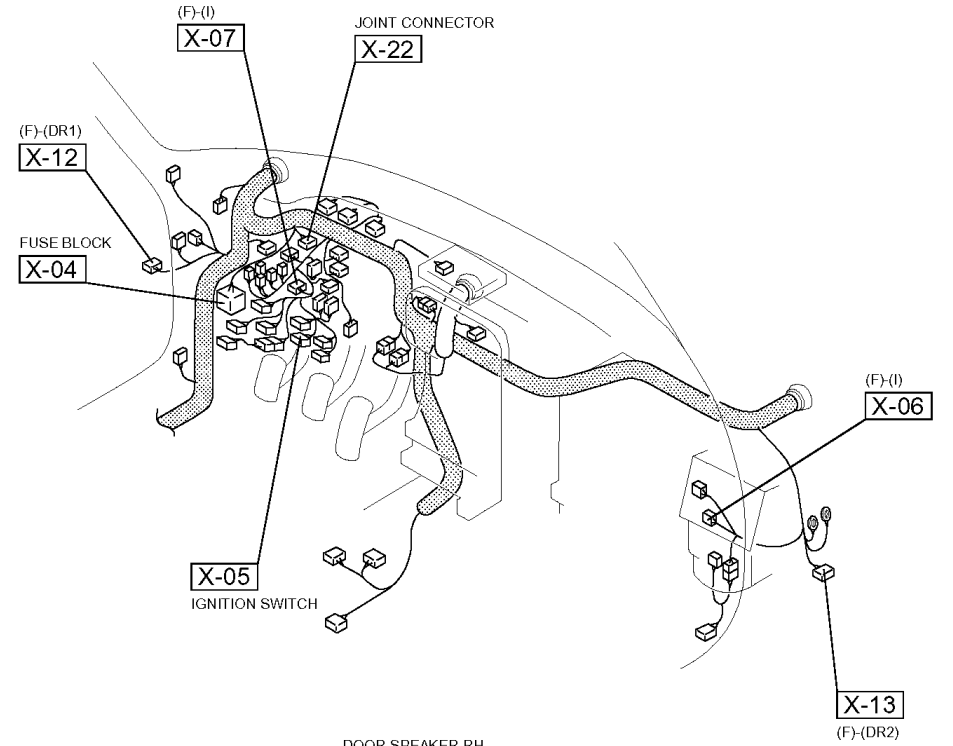
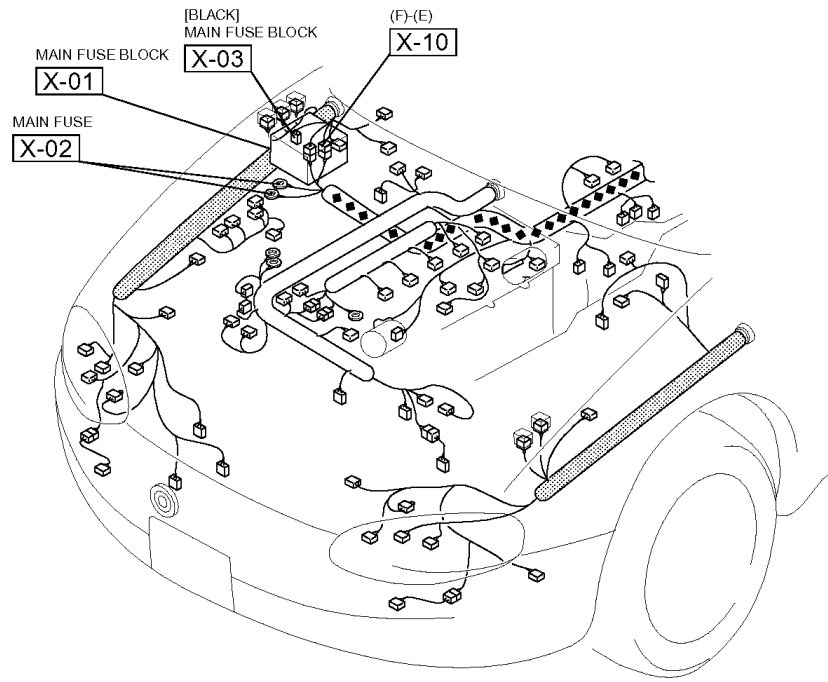

# Audio System (Bose Audio) \ J-2

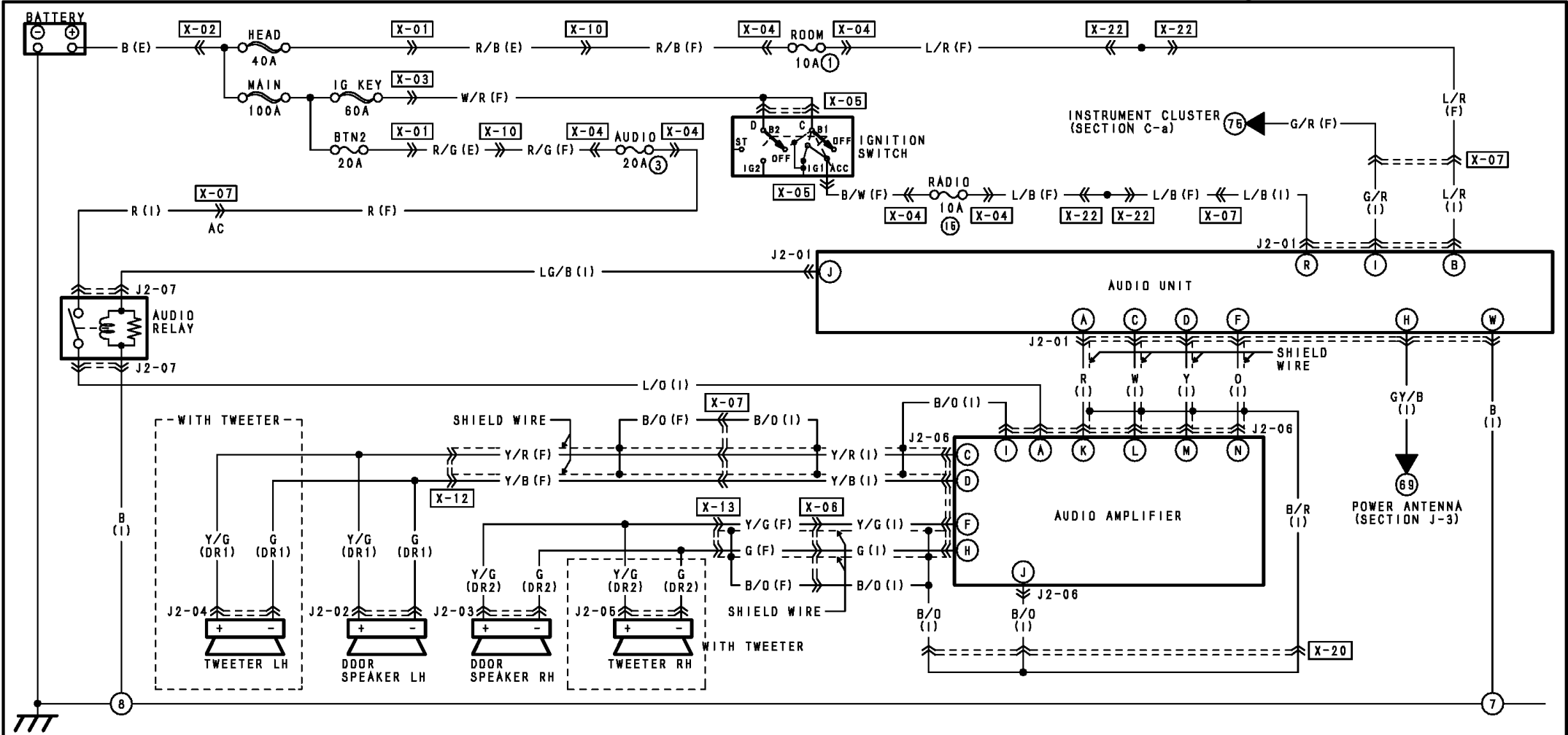

J2-01 AUDIO UNIT (1)

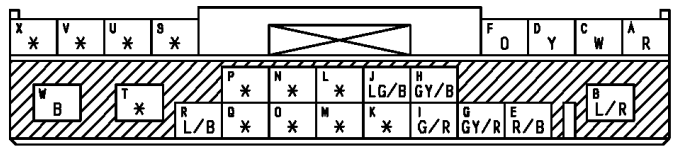

J2-02 DOOR SPEAKER LH (DR1)



J2-03 DOOR SPEAKER RH (DR2)



J2-04 TWEETER LH (DR1)

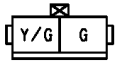

(WITH TWEETER)

J2-05 TWEETER RH (DR2)

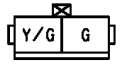

(WITH TWEETER)

J2-06 AUDIO AMPLIFIER (1)

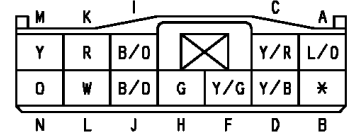

J2-07 AUDIO RELAY (1)

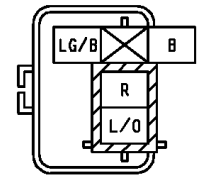



HARNES SYMBOL :  (F)  (E)  (R)

# Audio System (Bose Audio) \ J-2

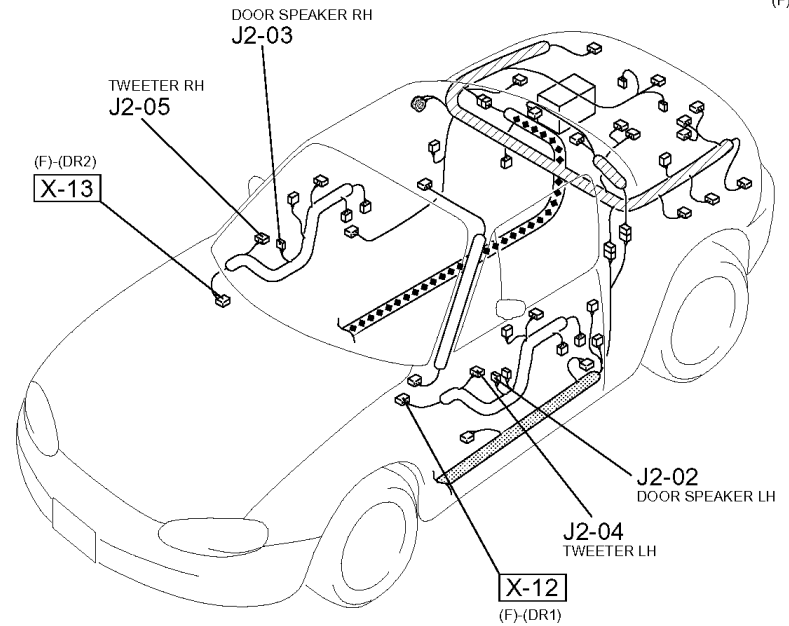
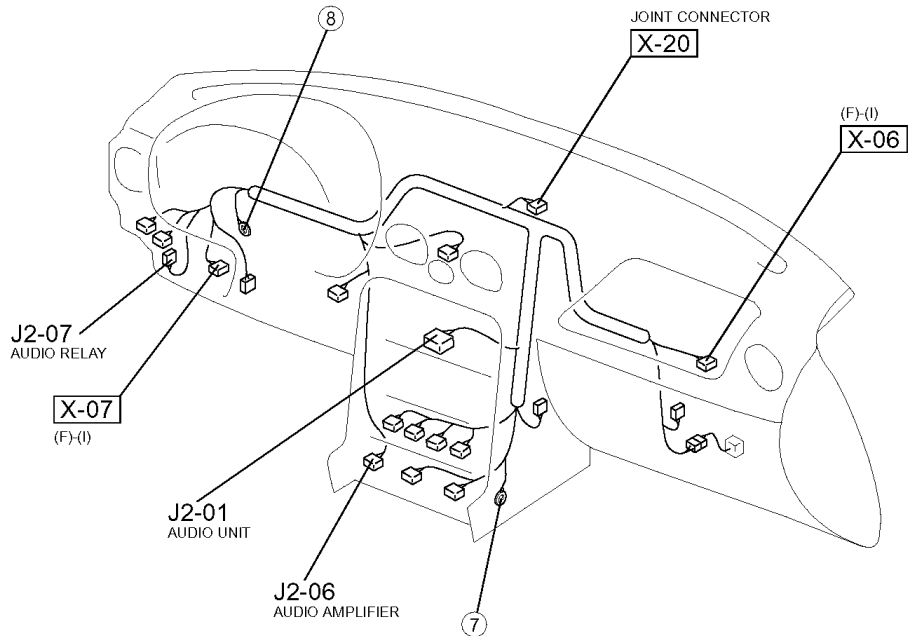
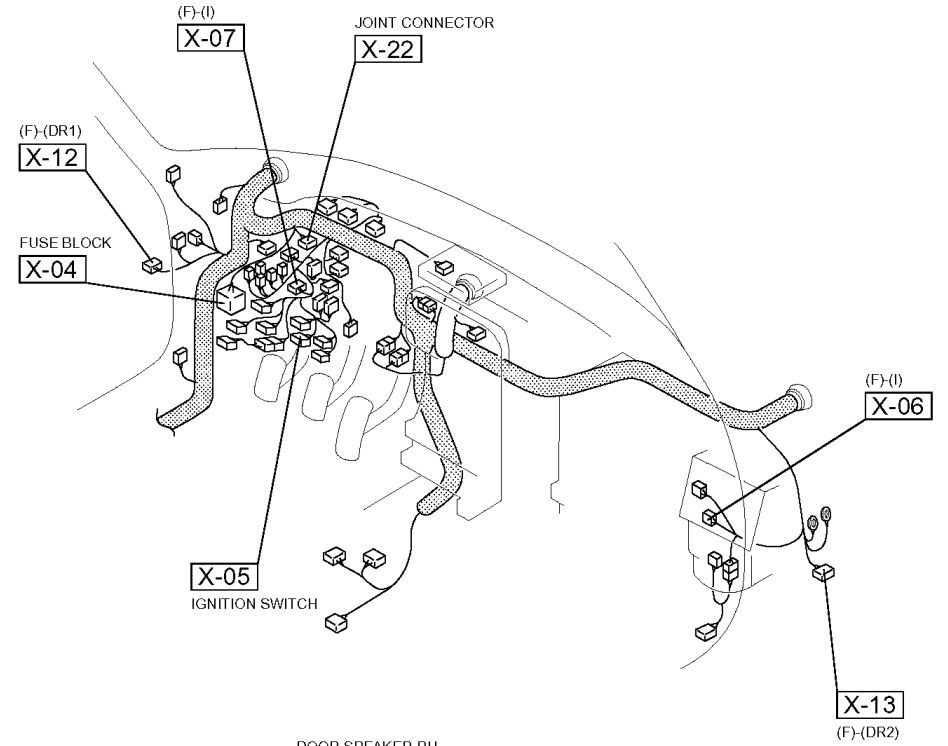
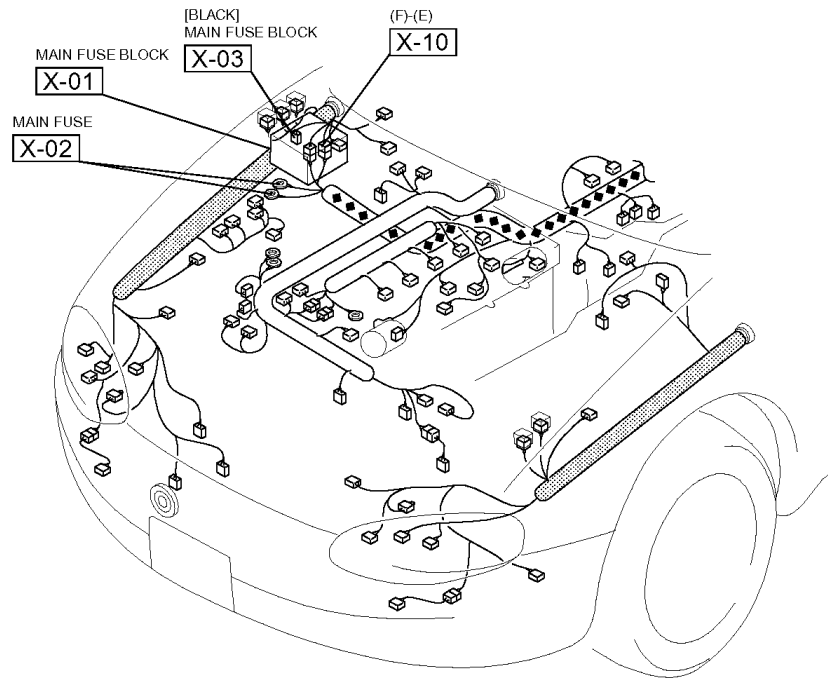

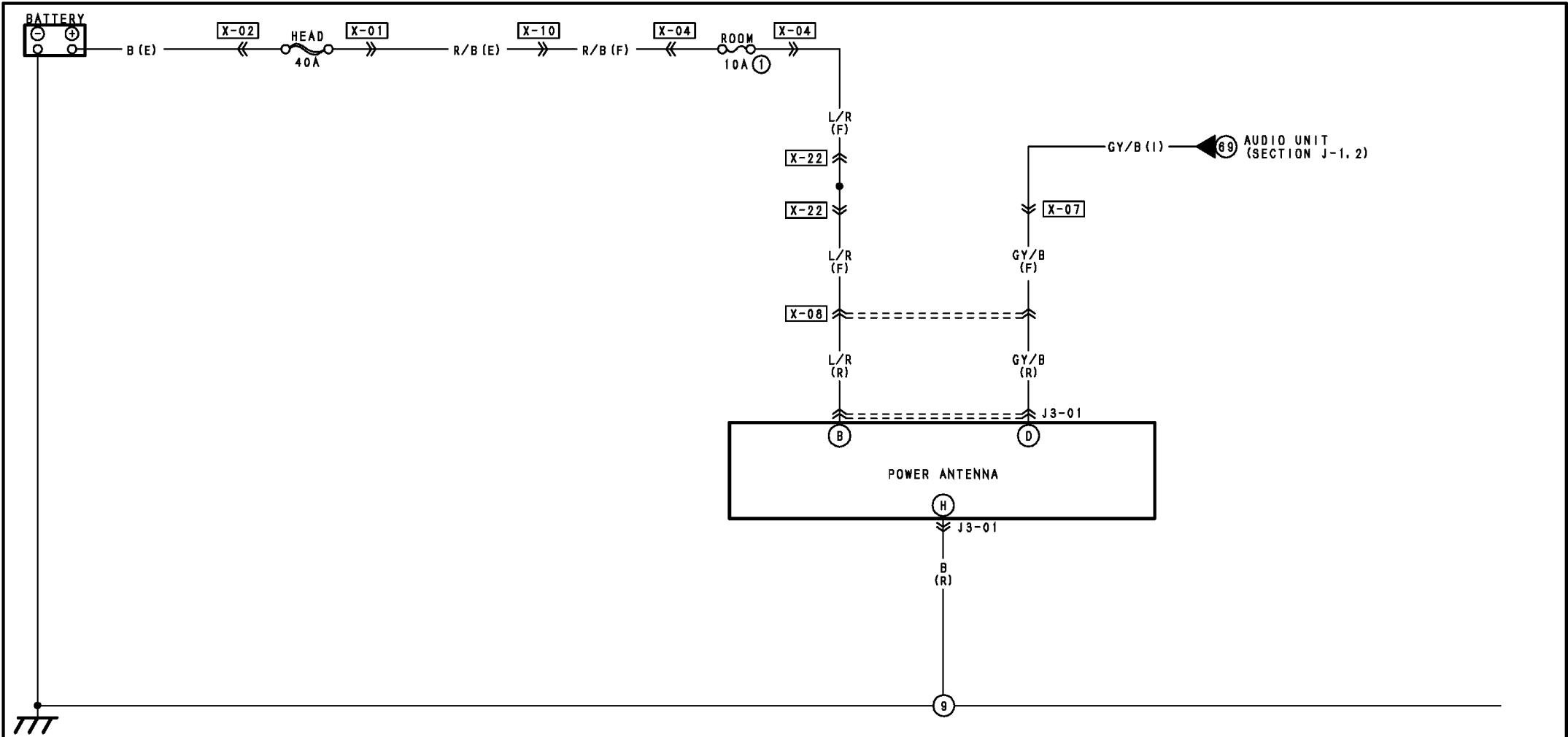

J3-01 POWER ANTENNA (R)

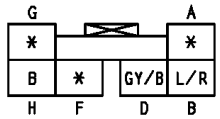

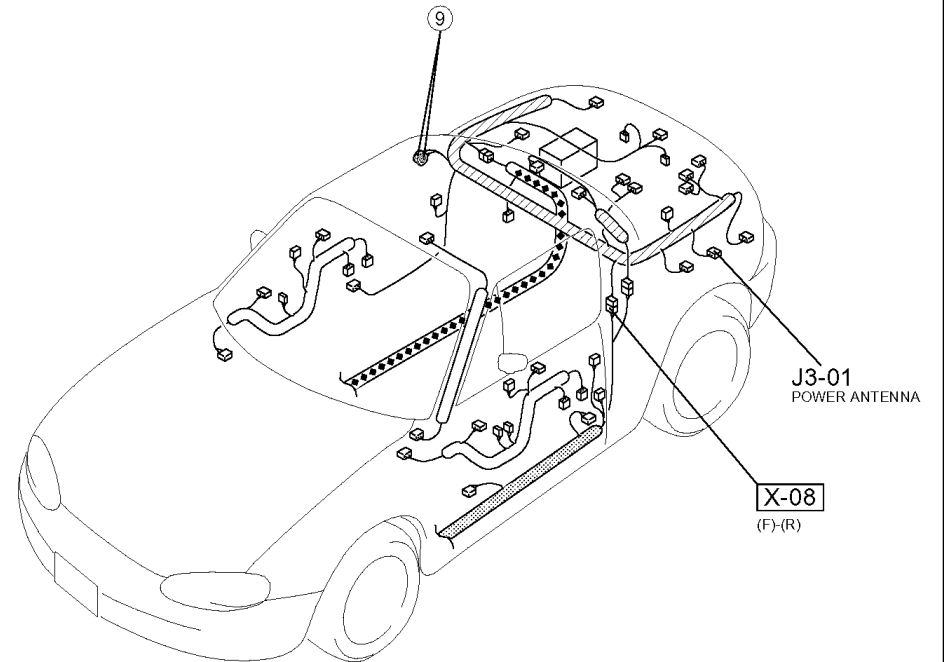
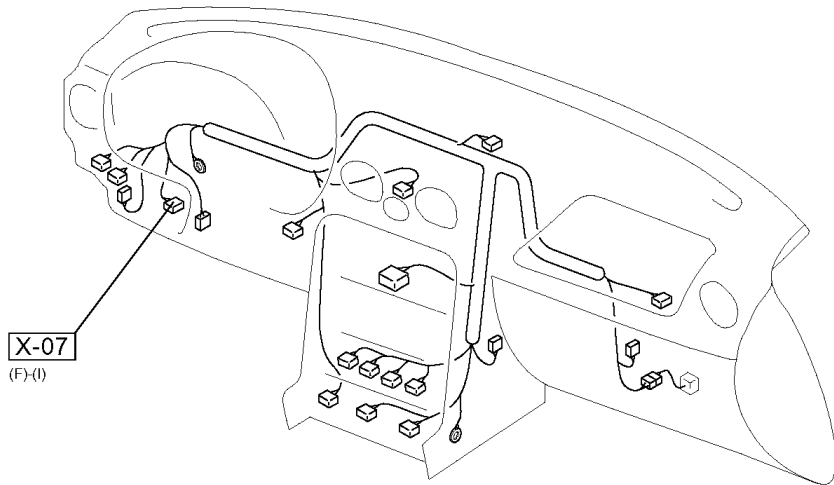
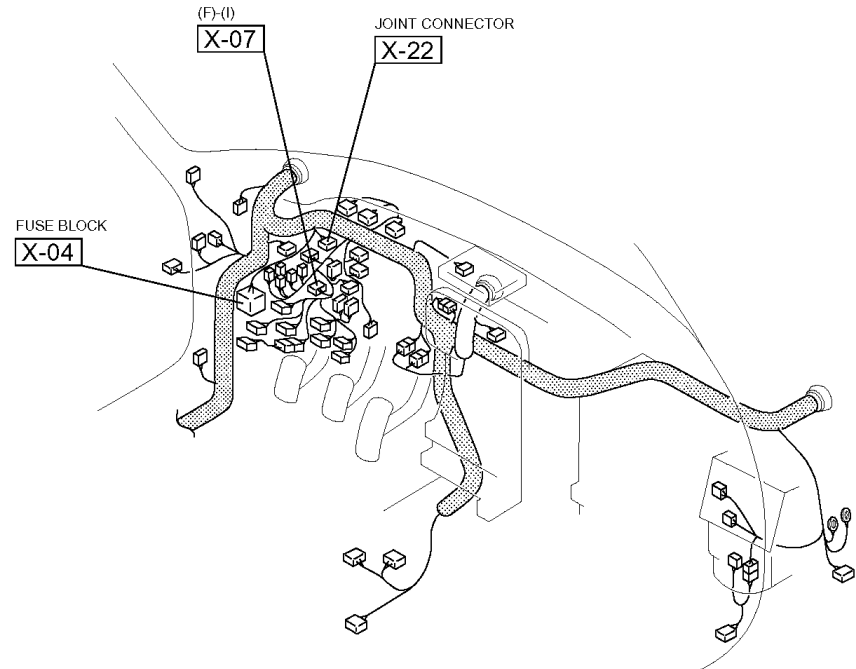
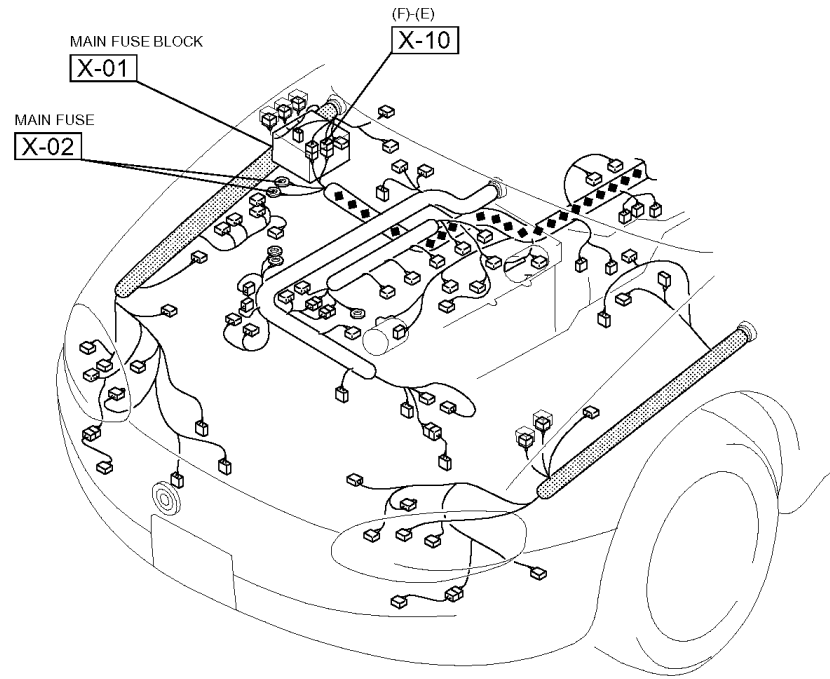

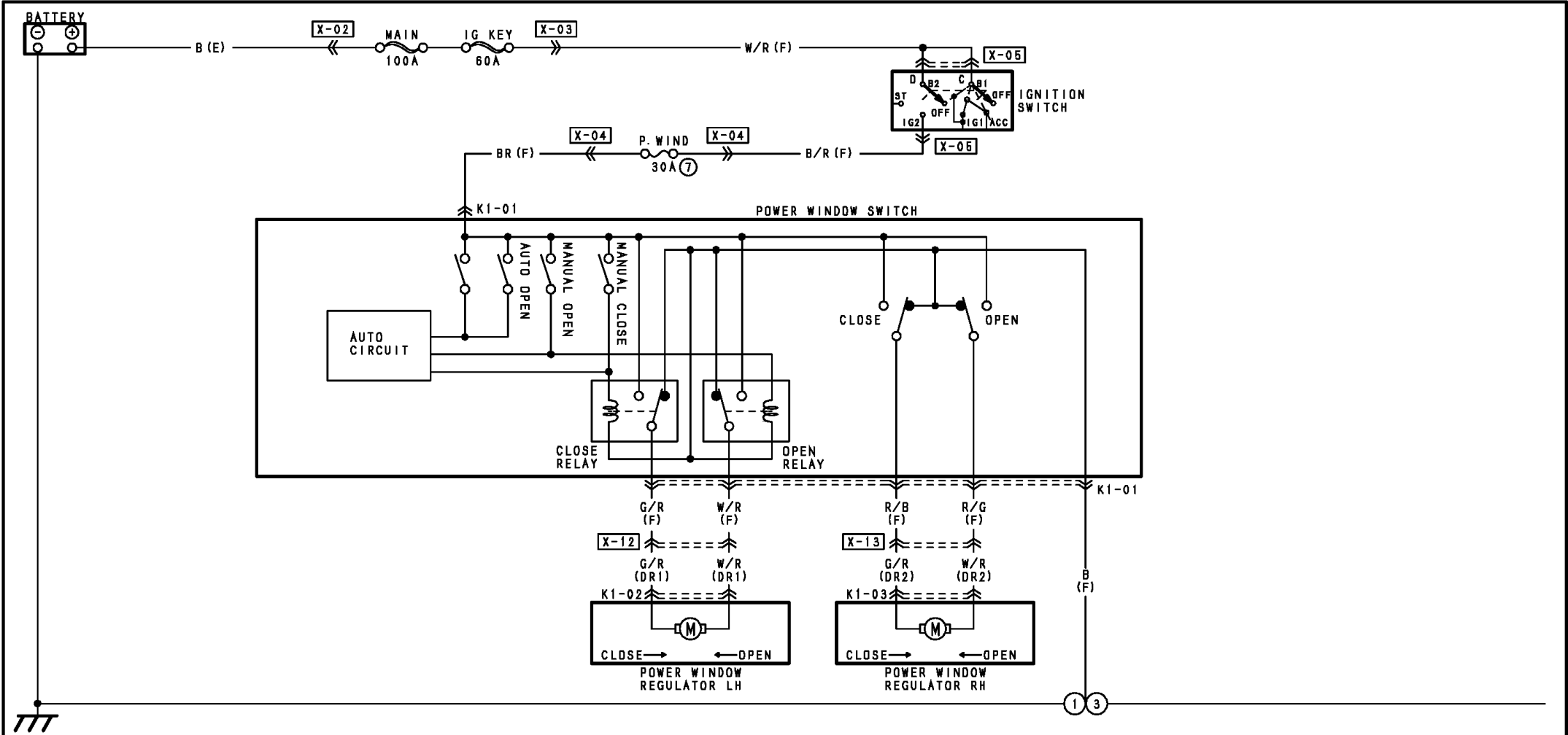
K1-01 POWER WINDOW SWITCH (F)	K1-02 POWER WINDOW REGULATOR LH (DR1)	K1-03 POWER WINDOW REGULATOR RH (DR2)	

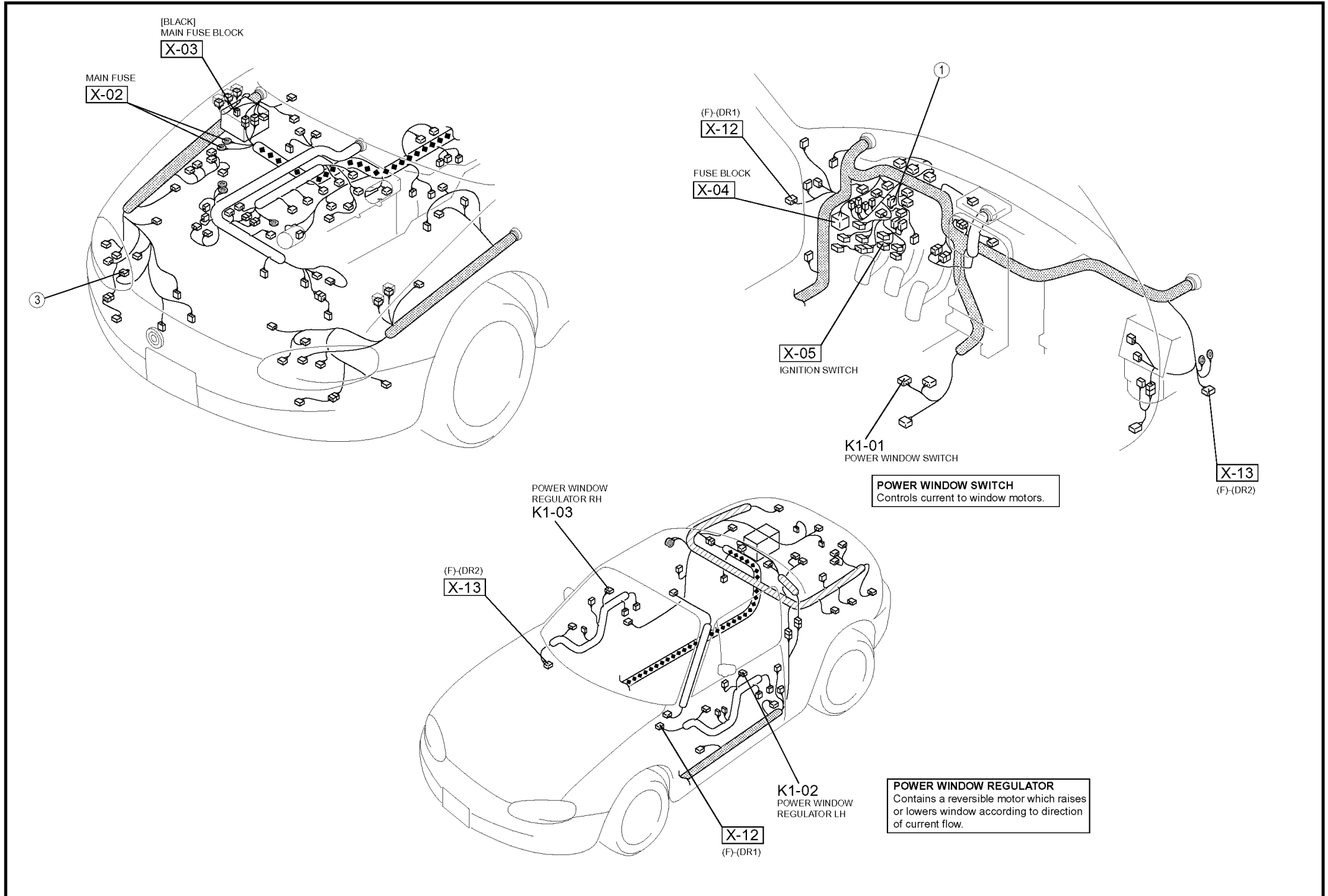

# Power Door Lock System \ K-2

< > WITH LOCK SWITCH

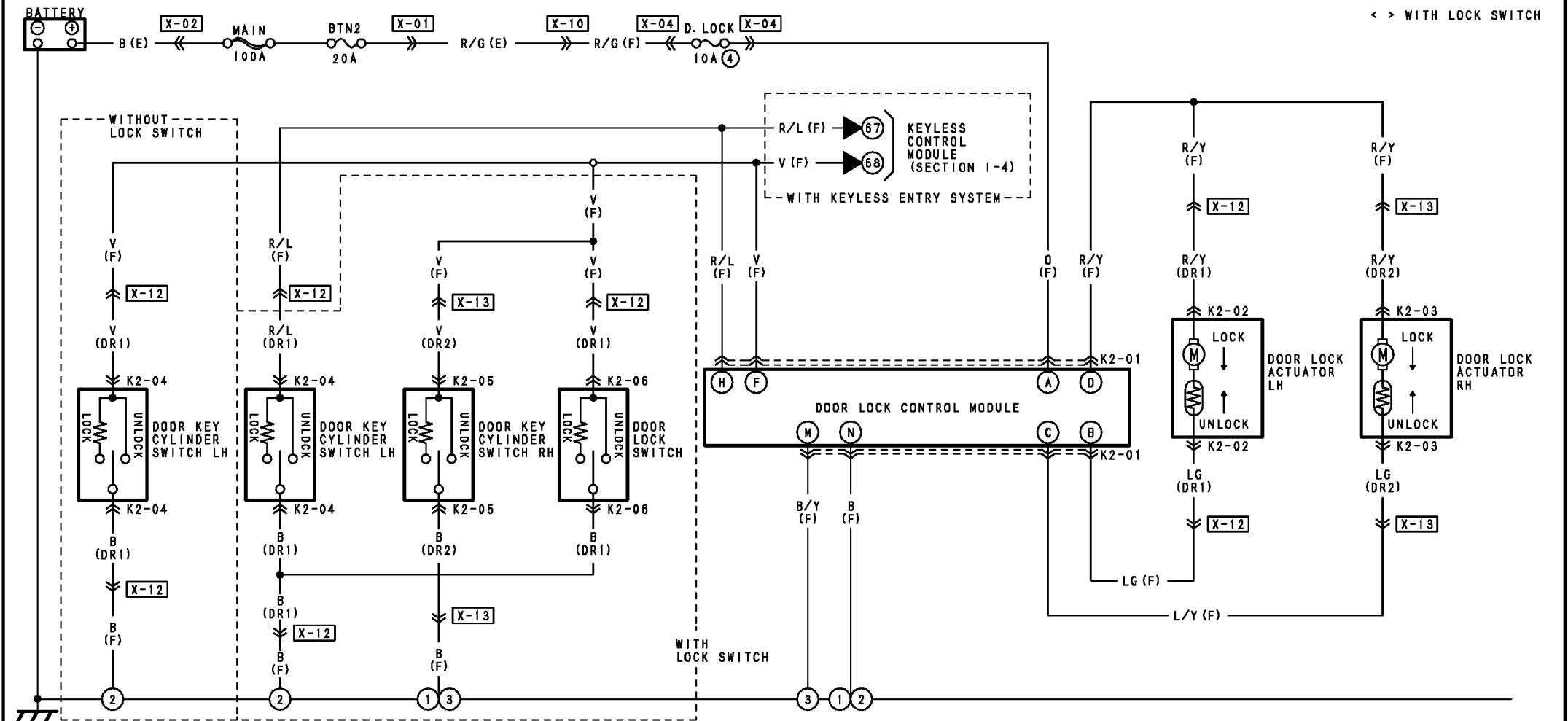

K2-01 DOOR LOCK CONTROL MODULE (F)

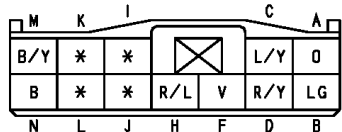

K2-02 DOOR LOCK ACTUATOR LH (DR1)



K2-03 DOOR LOCK ACTUATOR RH (DR2)



K2-04 DOOR KEY CYLINDER SWITCH LH (DR1)

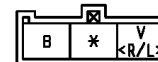

K2-05 DOOR KEY CYLINDER SWITCH RH (DR2)

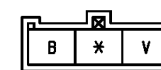

(WITH LOCK SWITCH)

K2-06 DOOR LOCK SWITCH (DR1)

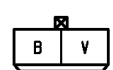

(WITH LOCK SWITCH)

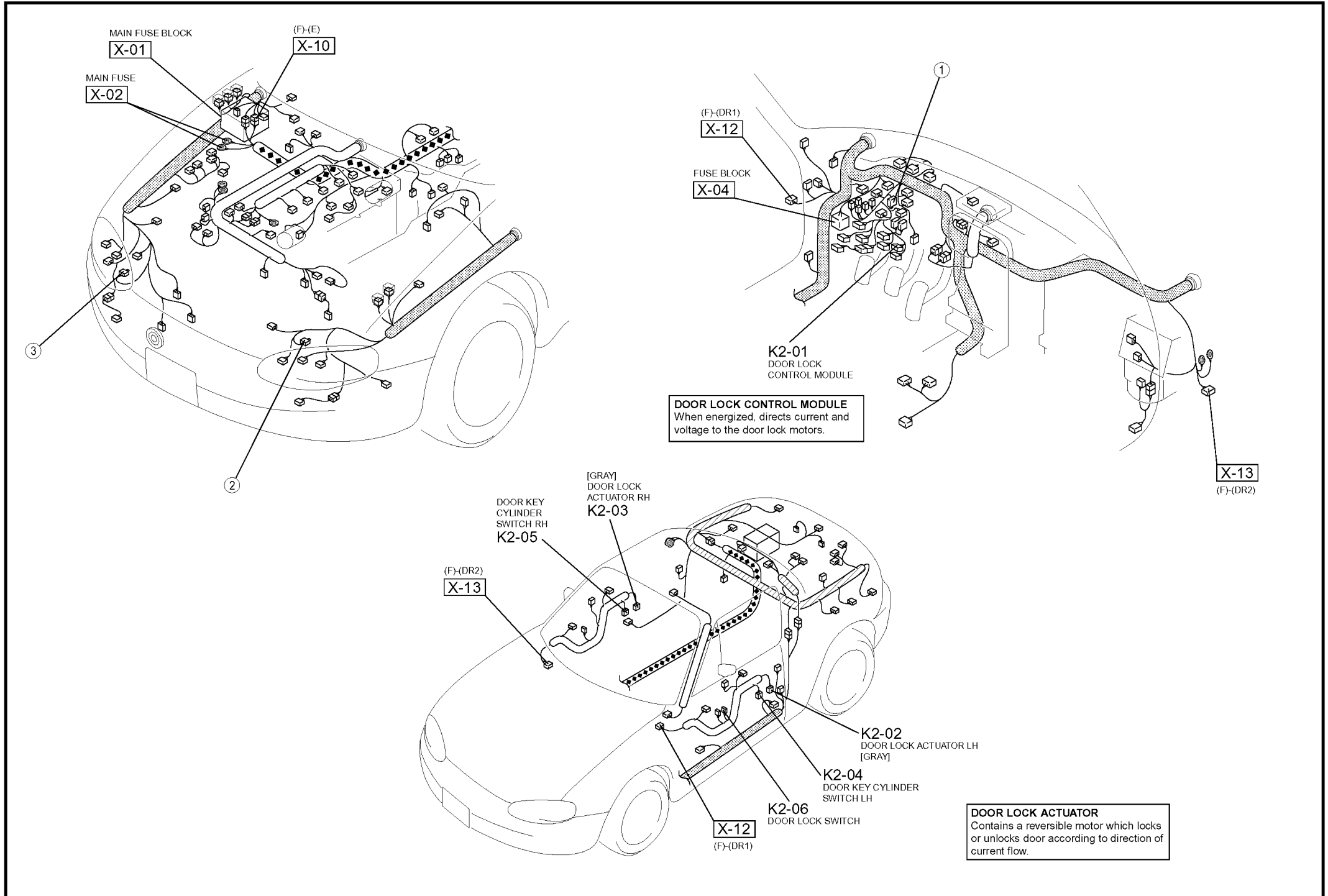

# Power Outside Mirrors \ L

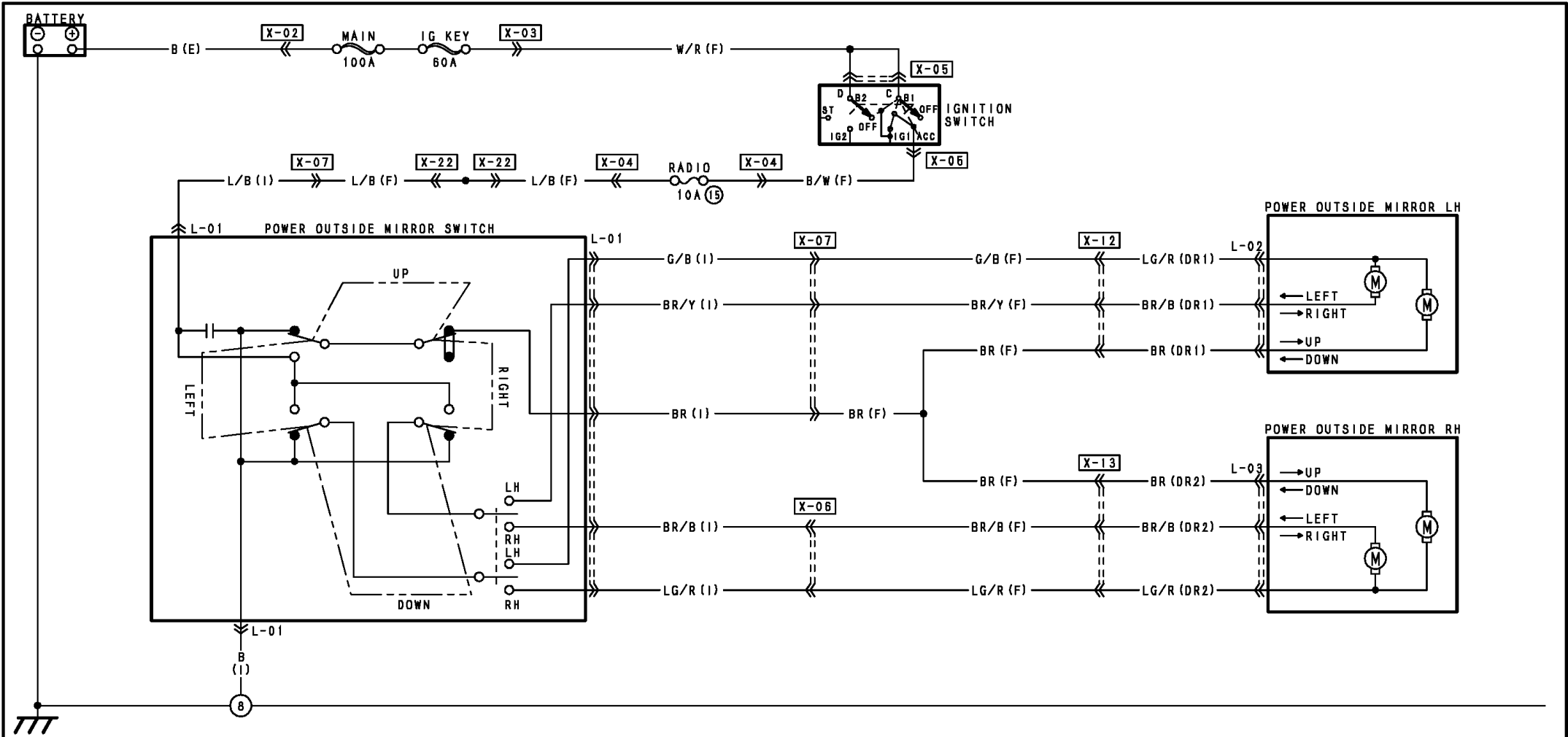

L-01 POWER OUTSIDE MIRROR SWITCH (I)

L/B	LG/R	G/B
B	BR	BR/B

L-02 POWER OUTSIDE MIRROR LH (DR1)

*	*	*
BR	LG/R	BR/B

L-03 POWER OUTSIDE MIRROR RH (DR2)

*	*	*
BR	LG/R	BR/B

--	--	--	--



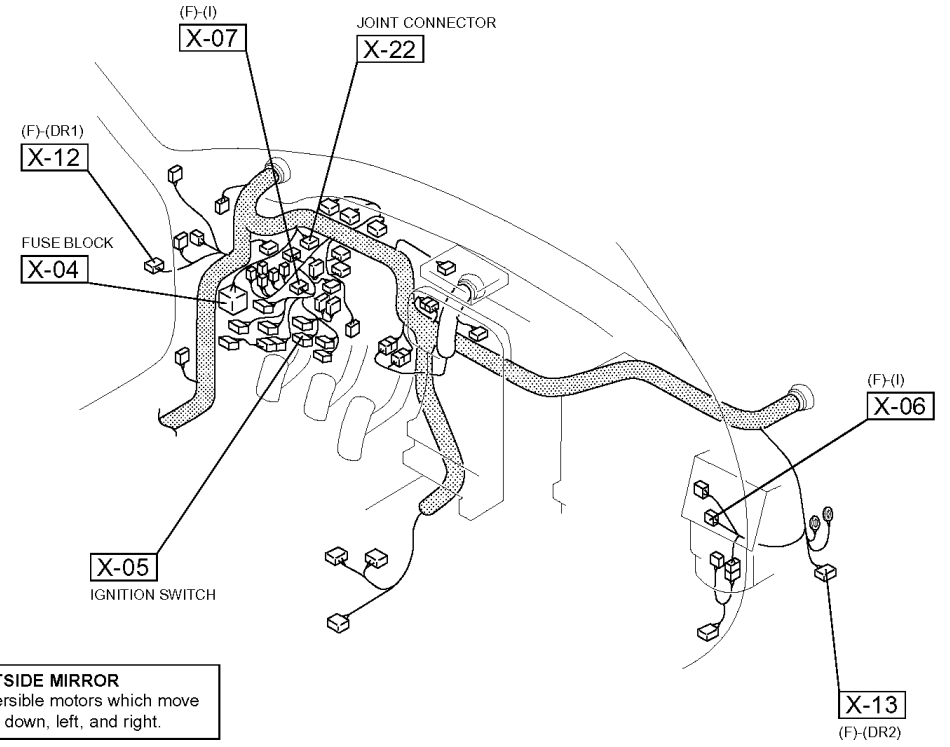
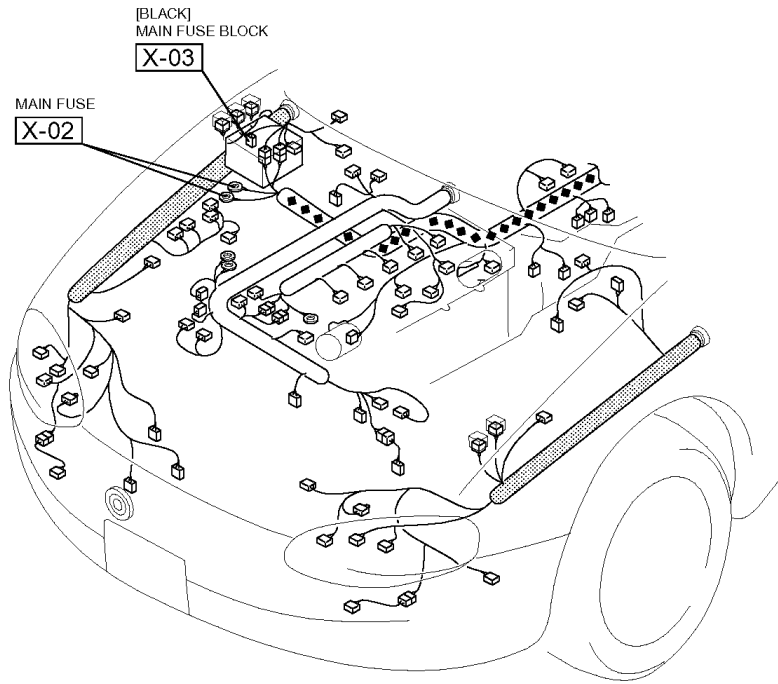

**POWER OUTSIDE MIRROR SWITCH**  
Controls current to power outside mirrors.

**POWER OUTSIDE MIRROR**  
Contains reversible motors which move the mirror up, down, left, and right.

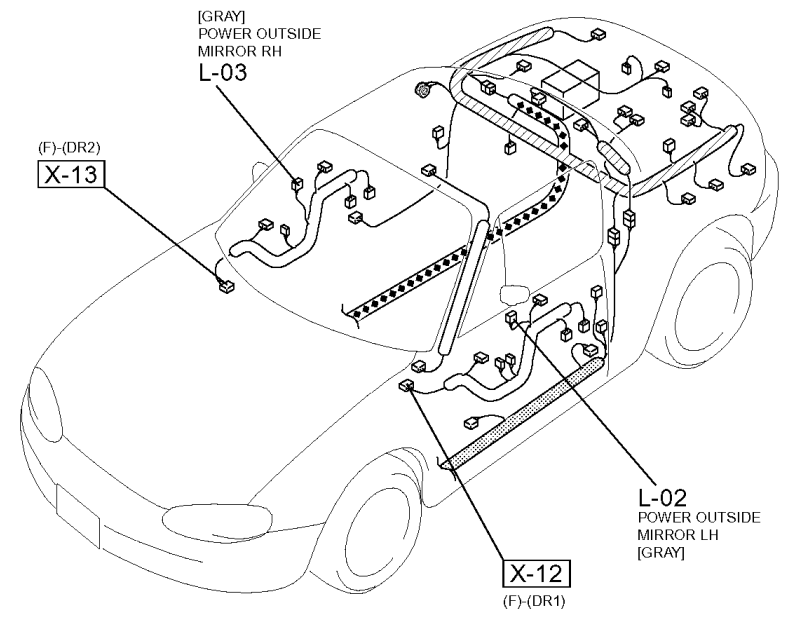
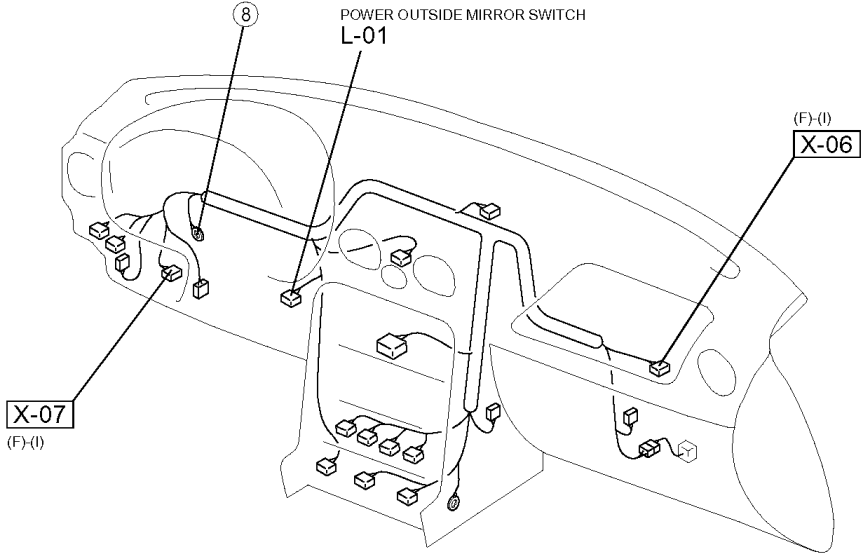

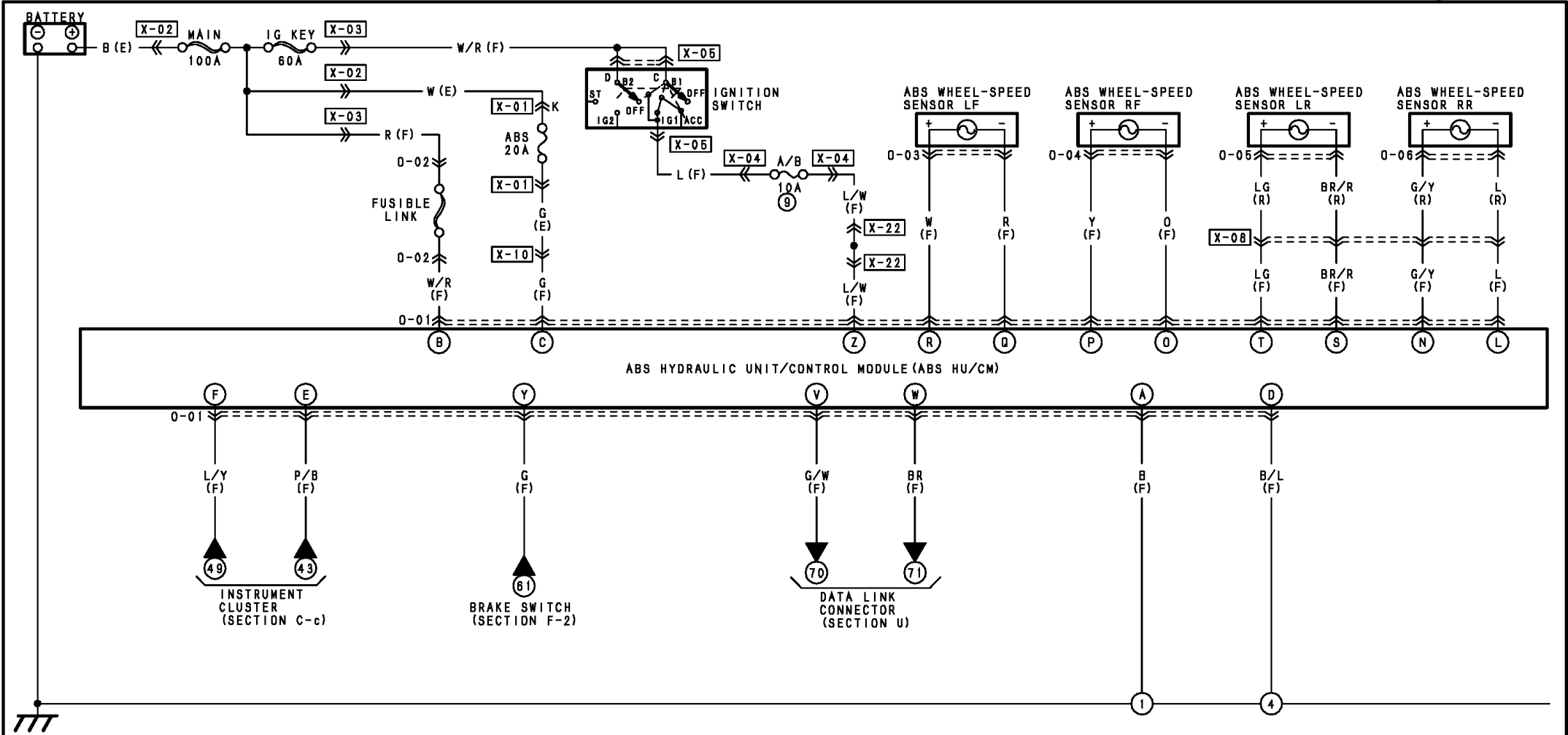

0-01 ABS HU/CM (F)

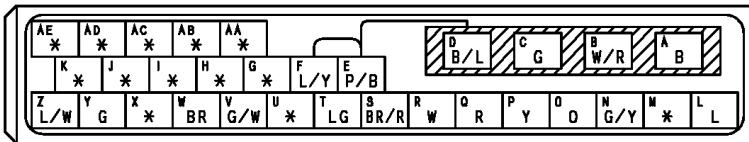

0-02 FUSIBLE LINK (F)



0-03 ABS WHEEL-SPEED SENSOR LF (F)

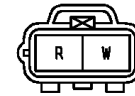

0-04 ABS WHEEL-SPEED SENSOR RF (F)

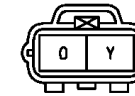

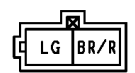

0-05 ABS WHEEL-SPEED SENSOR LR (R)

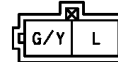

0-06 ABS WHEEL-SPEED SENSOR RR (R)



HARNES SYMBOL :  (F)  (E)  (R)

# Antilock Brake System \ O-a

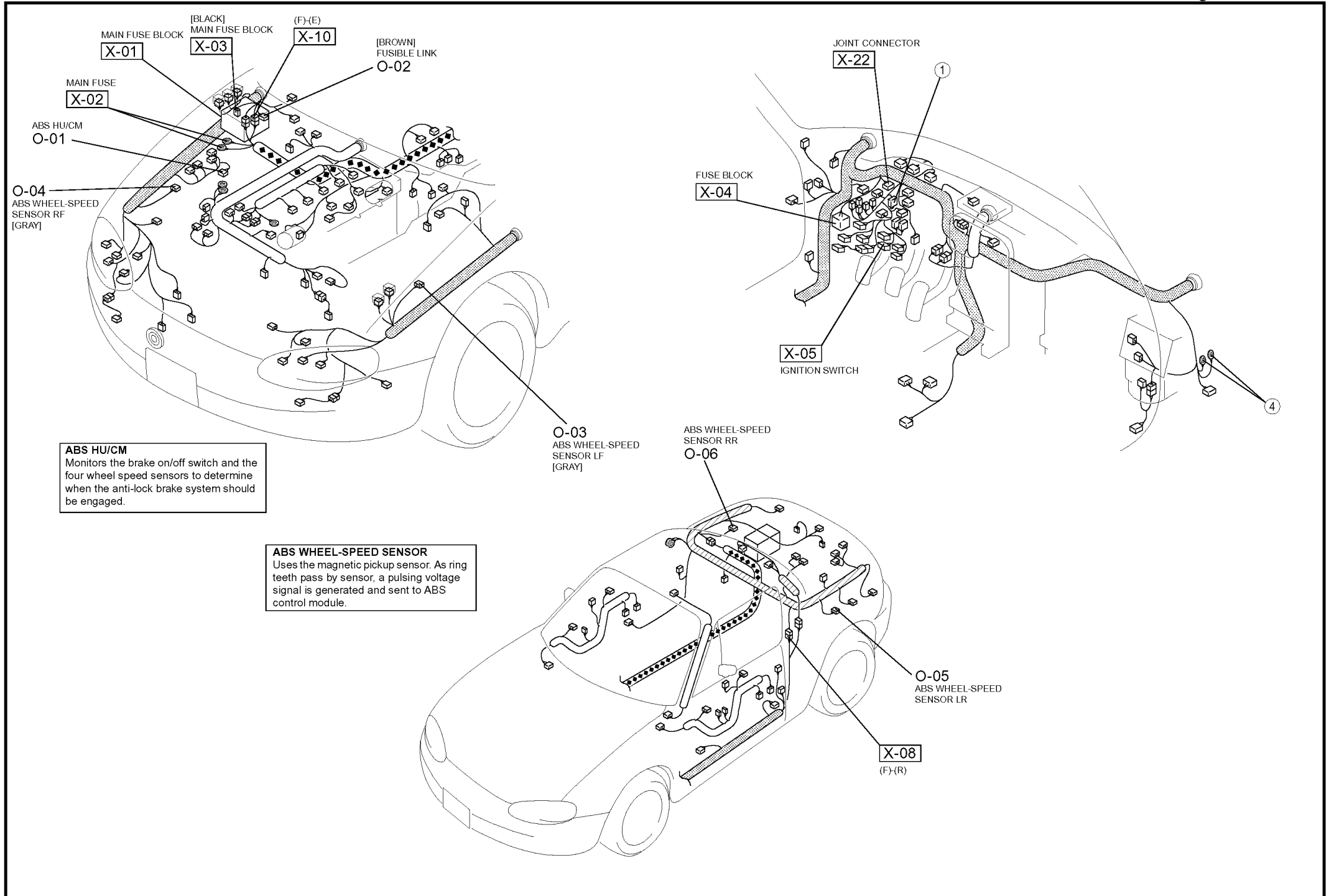

**ABS HU/CM**  
Monitors the brake on/off switch and the four wheel speed sensors to determine when the anti-lock brake system should be engaged.

**ABS WHEEL-SPEED SENSOR**  
Uses the magnetic pickup sensor. As ring teeth pass by sensor, a pulsing voltage signal is generated and sent to ABS control module.

# Cruise Control System | Q

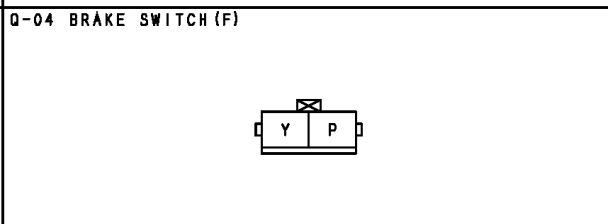
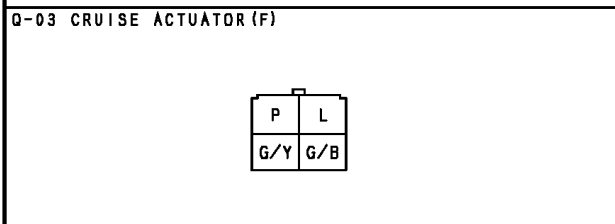
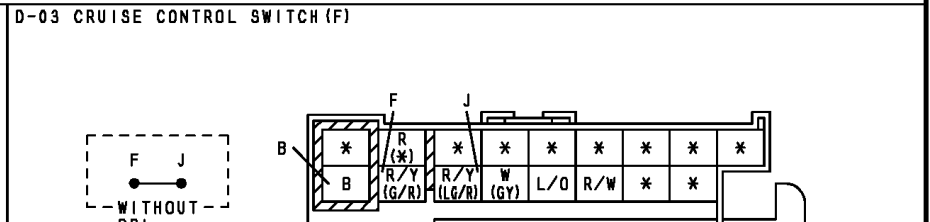
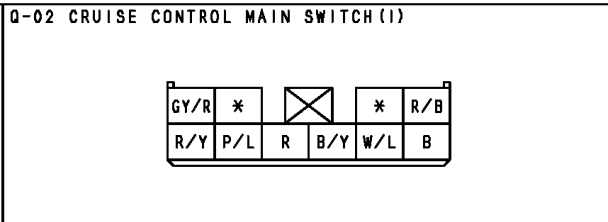
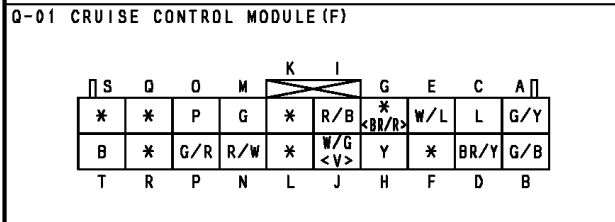
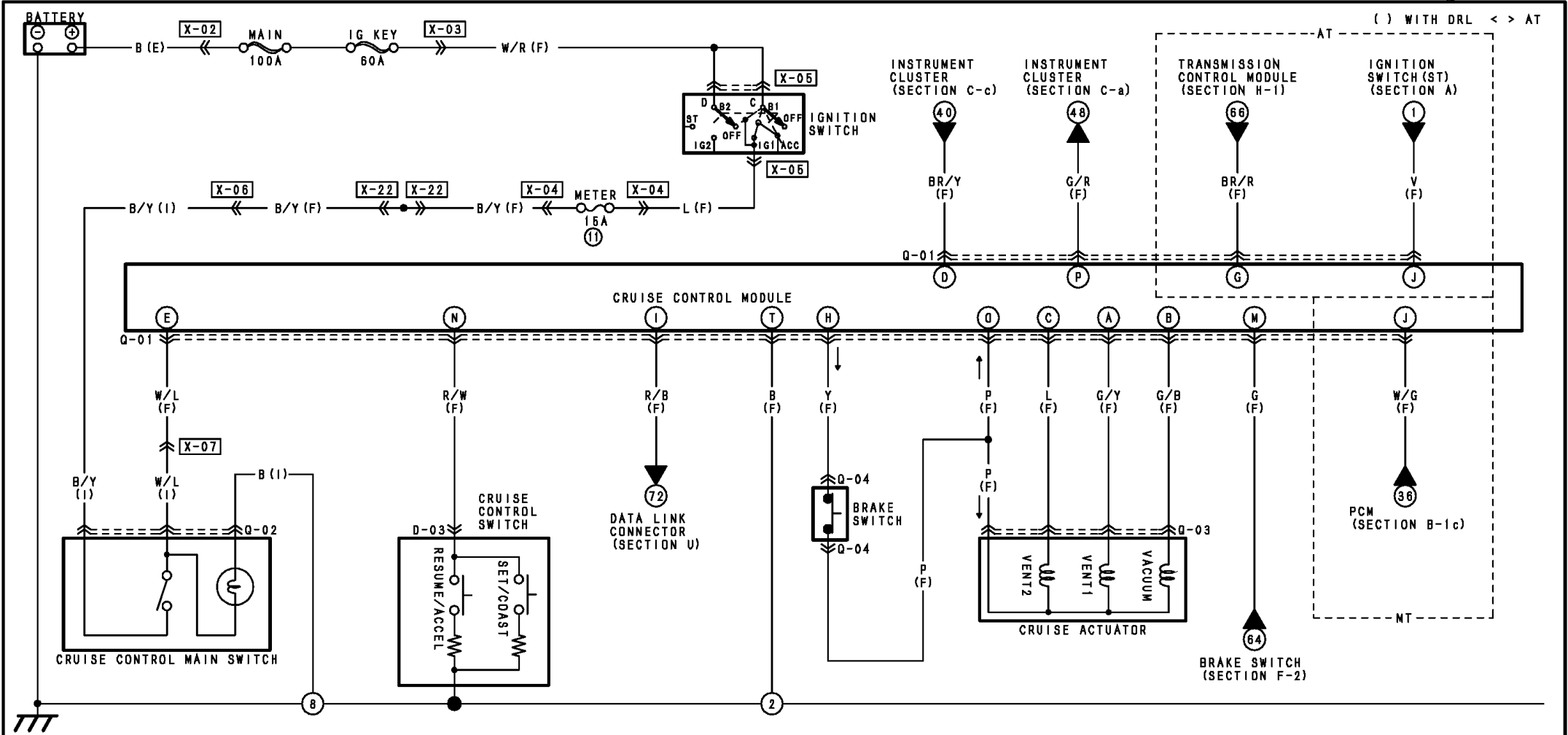

HARNESS SYMBOL :  (F)  (E)  (R)

# Cruise Control System \ Q

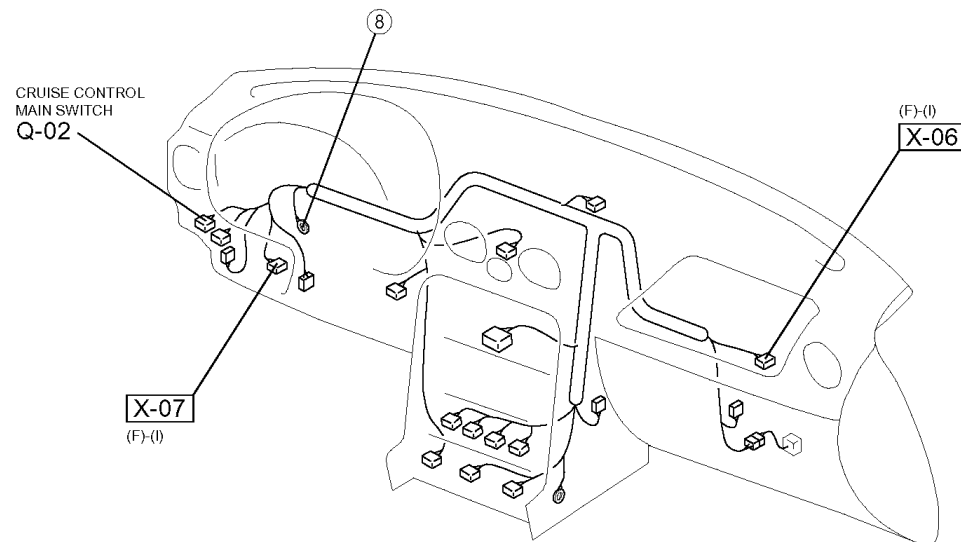
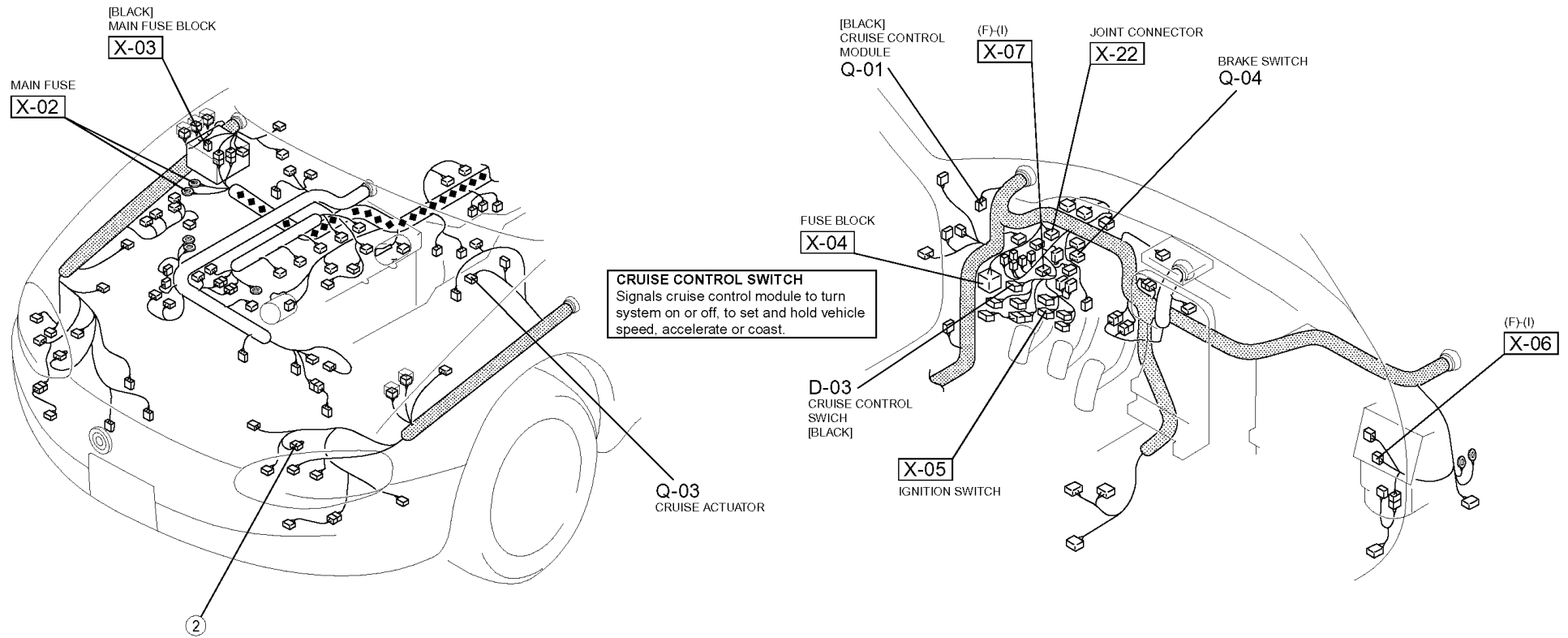

# AIR BAG SYSTEM

## AIR BAG SYSTEM SERVICE WARNINGS

### Component Disassembly

- Disassembling and reassembling the components of the air bag system can render the system inoperative, which may result in serious injury or death in the event of an accident. Do not disassemble any air bag system component.

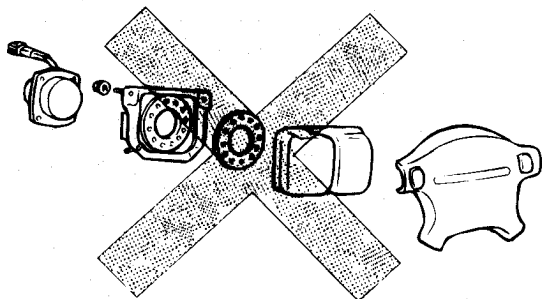

X5U810WAW3

### Air Bag Module Inspection

- Inspecting the air bag module by using an ohmmeter can deploy the air bag module, which may cause serious injury. Do not use an ohmmeter to inspect the air bag module. Always use the on-board diagnostic function to diagnose the air bag for malfunctions. (Refer to (0802) DIAGNOSTIC TROUBLE CODE TABLE [AIR BAG SYSTEM].)

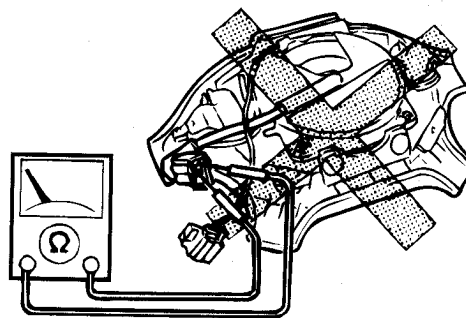

X5U810WA0

### Wiring Harness Repair

- Incorrectly repairing an air bag system wiring harness can accidentally deploy the air bag module, which can cause serious injury. If a problem is found in the system wiring, replace the wiring harness. Do not try to repair it.

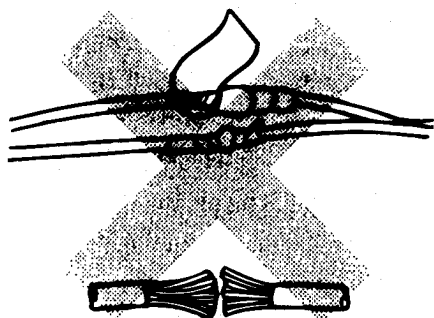

X5U810WA4

### Air Bag Module Handling

- A live (undeployed) air bag module may accidentally deploy when it is handled and cause serious injury. When carrying a live (undeployed) air bag module, point the front surface away from your body to lessen the chance of injury in case it deploys.

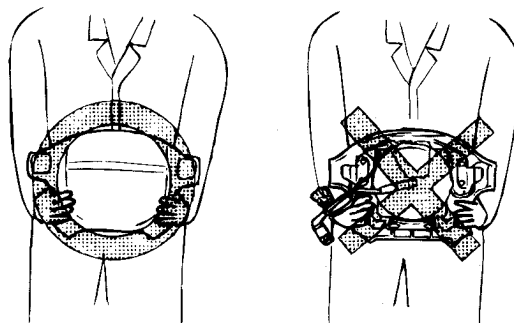

RIGHT

WRONG

X5U810WA1

AIR BAG SYSTEM SERVICE CAUTIONS/SERVICE WARNINGS

\*The references in this section can be found in Workshop Manual[1662-10-99G(1999-7)]

- A live (undeployed) air bag module placed face down on a surface is dangerous. If the air bag module deploys, the motion of the module can cause serious injury. Always face the front surface up to reduce the motion of the module in case it accidentally deploys.

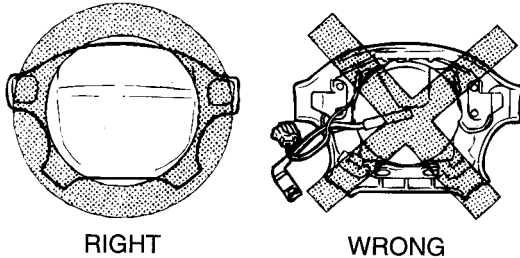

RIGHT

WRONG

XSU810WA2

#### SAS Control Module Handling

- Disconnecting the SAS control module connector or removing the SAS control module with the ignition switch at ON can cause the air bag modules to deploy, which may seriously injure you. Before disconnecting the SAS control module connector or removing the SAS control module, turn the ignition switch to LOCK, then disconnect the negative battery cable and wait for more than 1 minute to allow the backup power supply of the SAS control module to deplete its stored power.
- Connecting the SAS control module connector without firmly installing the SAS control module to the vehicle is dangerous. The crash sensor inside the control module may send an electrical signal to the air bag modules. This will deploy the air bag modules, which may result in serious injury. Therefore, before connecting the connector, firmly mount the control module to the vehicle.

- For vehicles with a single point sensor, once an air bag is deployed due to an accident or other causes, the SAS control module must be replaced with a new one even if the used one does not have any external signs of damage. The used SAS control module may have been damaged internally which may cause improper operation, resulting in major injuries or even death. The used single point SAS control module cannot be bench-checked or self-checked.

#### Component Handling

- Oil, grease, water, etc. on components may cause the air bag to fail to deploy in an accident, which may cause serious injury. Do not allow oil, grease, water, etc. on components.
- Inserting a screwdriver, etc. into the connector of the air bag module may damage the connector and cause the air bag module to deploy improperly, which may cause serious injury. Do not insert any foreign objects into the connector.

#### Component Reusing

- Once an air bag module is deployed due to an accident or other causes, even if it does not have any external signs of damage, the air bag module may have been damaged internally which may cause improper operation. The improper operation may cause serious injury. Always self-check the undamaged air bag module to determine whether it can be reused. (Refer to (0802) *DIAGNOSTIC TROUBLE CODE TABLE [AIR BAG SYSTEM]*.)

\*The references in this section can be found in Workshop Manual[1662-10-99G(1999-7)]

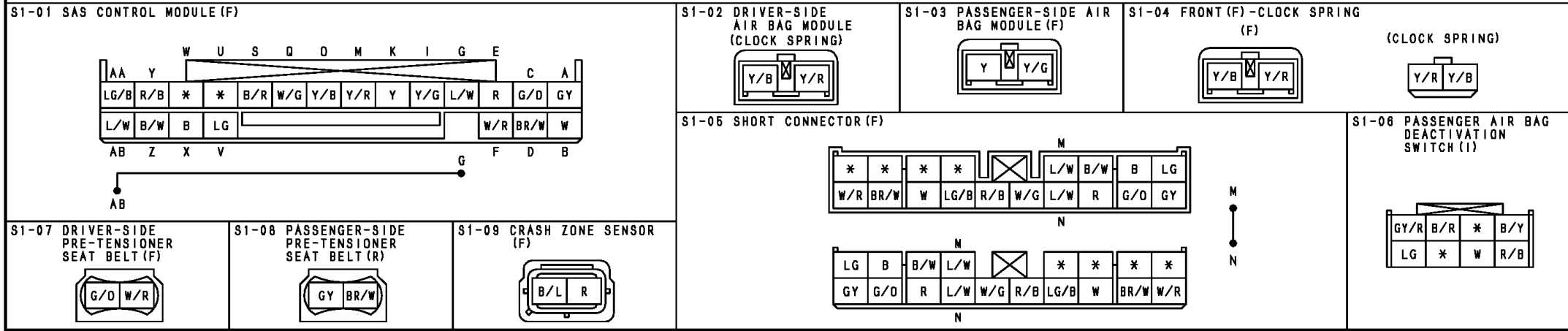
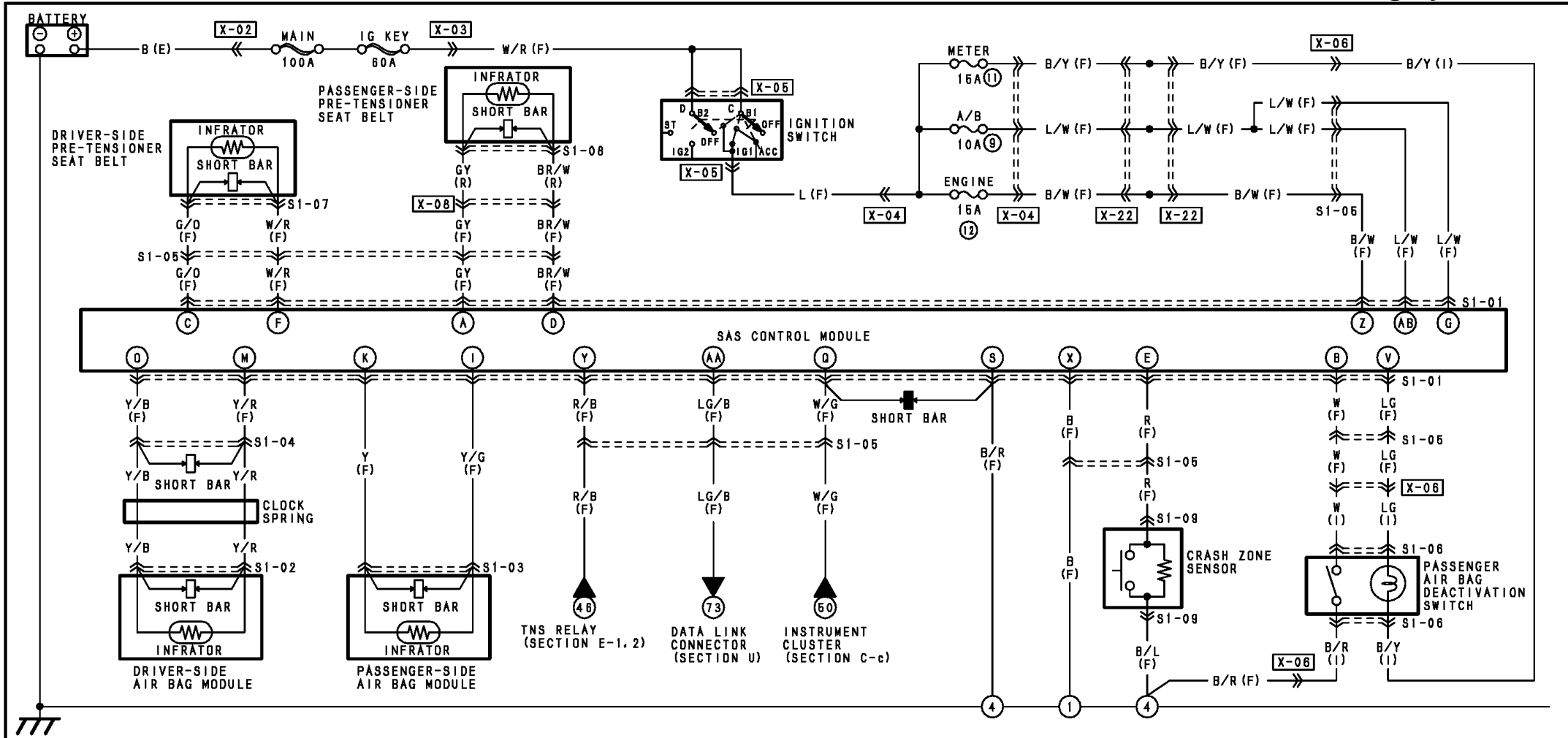



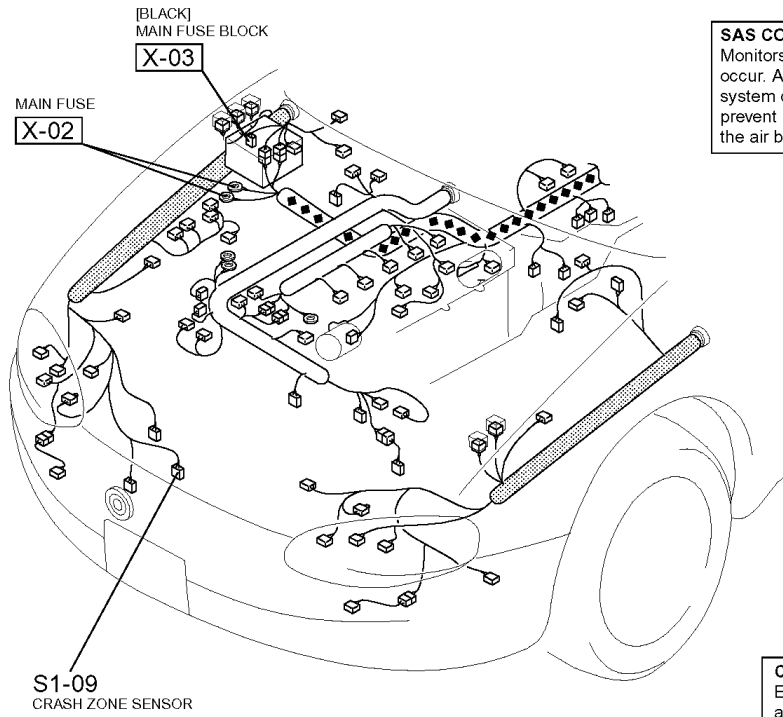

**SAS CONTROL MODULE**  
Monitors shock level when collisions occur. Also, monitors air bag electrical system components and connections to prevent mis-operation or no operation of the air bag.

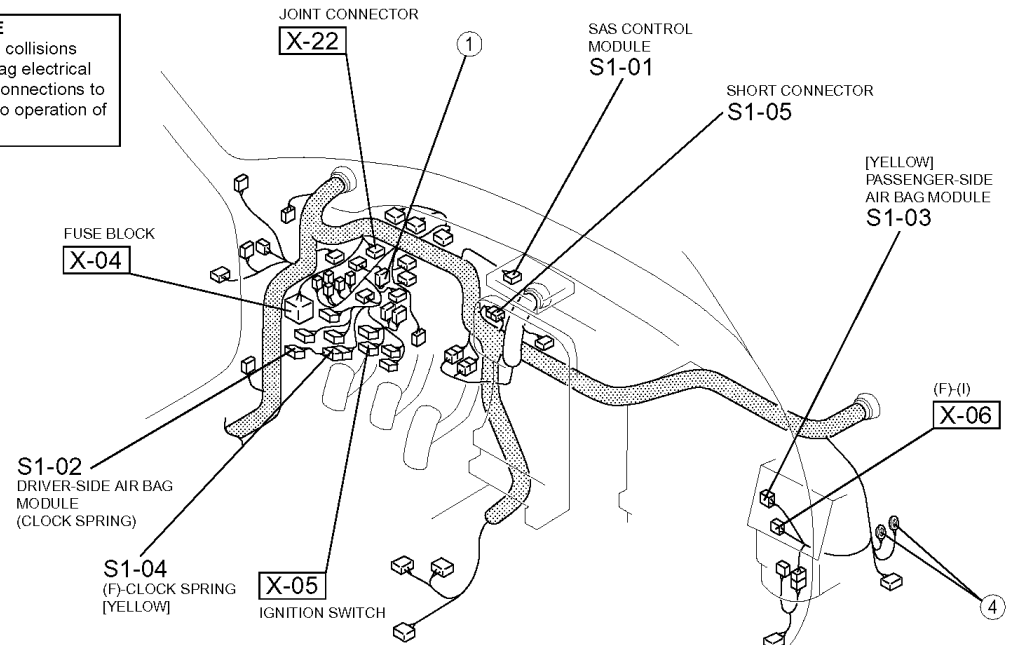

**CLOCK SPRING**  
Electrically connects steering wheel and air bag to body harness.

PASSENGER-SIDE PRE-TENSIONER SEAT BELT  
S1-08

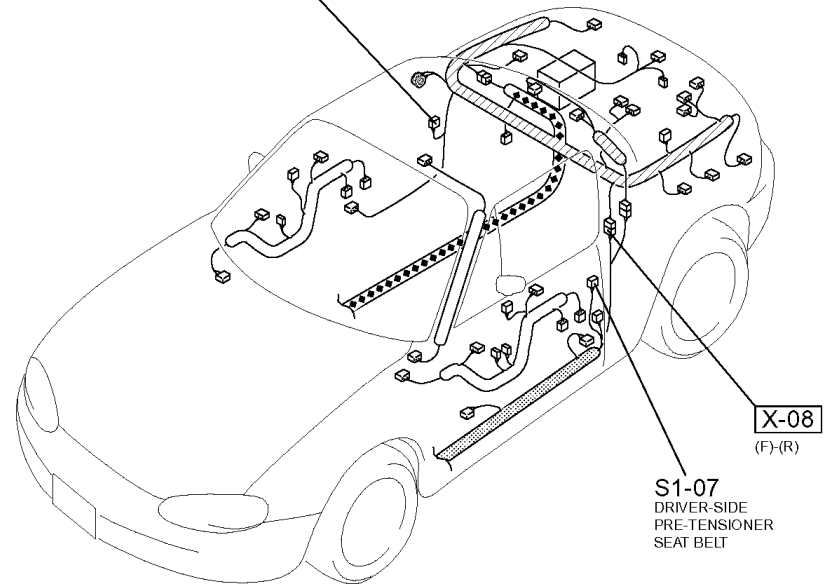
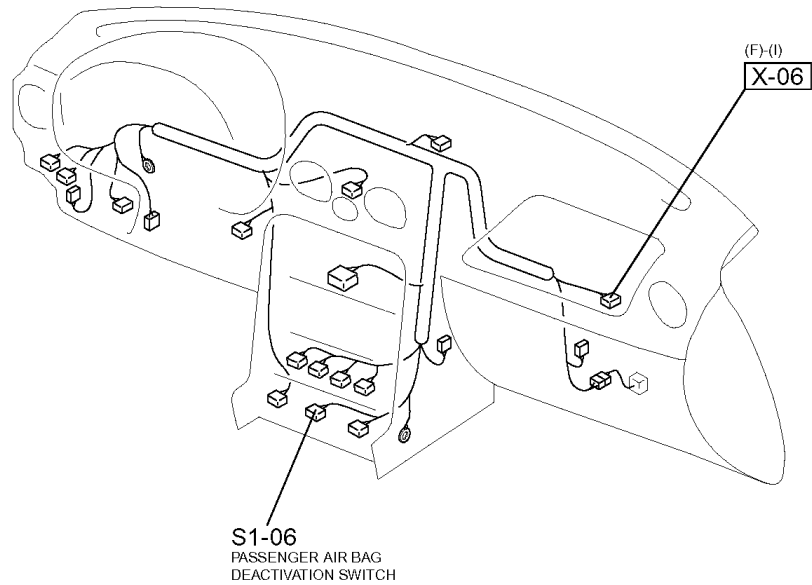

# Immobilizer System \ T

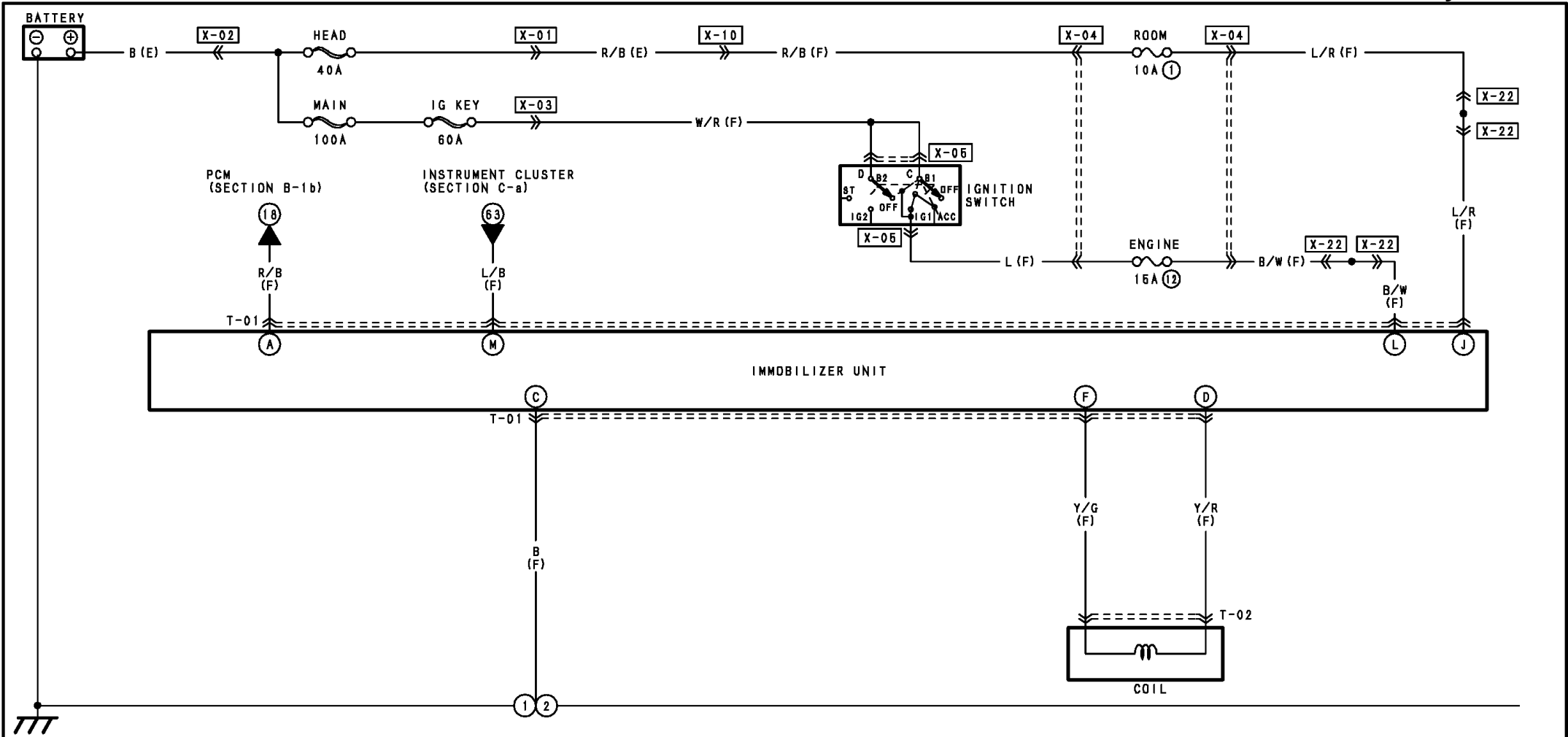

T-01 IMMOBILIZER UNIT (F)

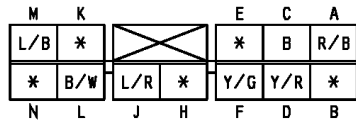

T-02 COIL (F)



HARNESS SYMBOL :  (F)  (E)  (R)

# Immobilizer System \ T

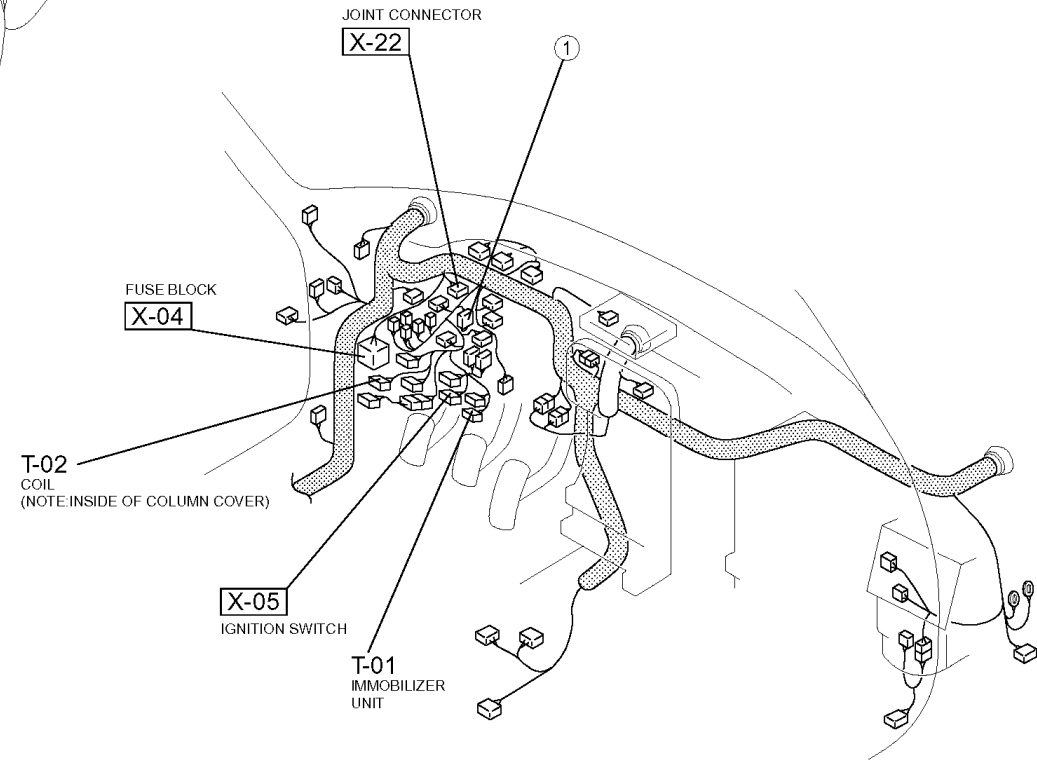
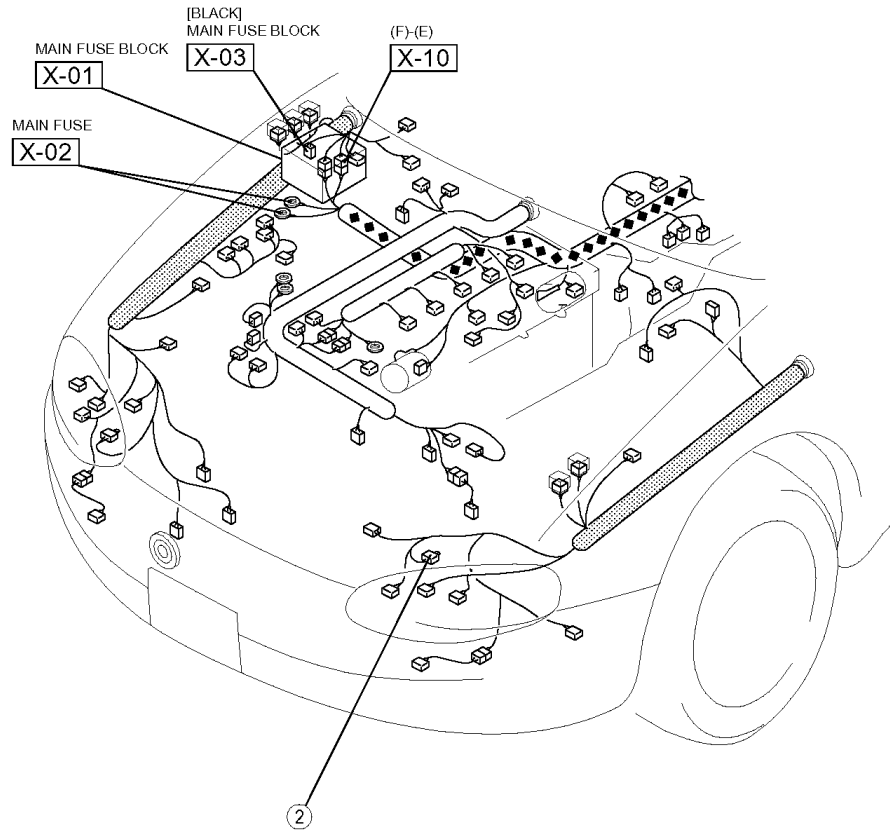

**IMMOBILIZER UNIT**  
 The immobilizer system prevents the engine from starting even if ignition switch is short-circuited. As a result, it keeps the vehicle from stolen.

[ ] WITH ABS

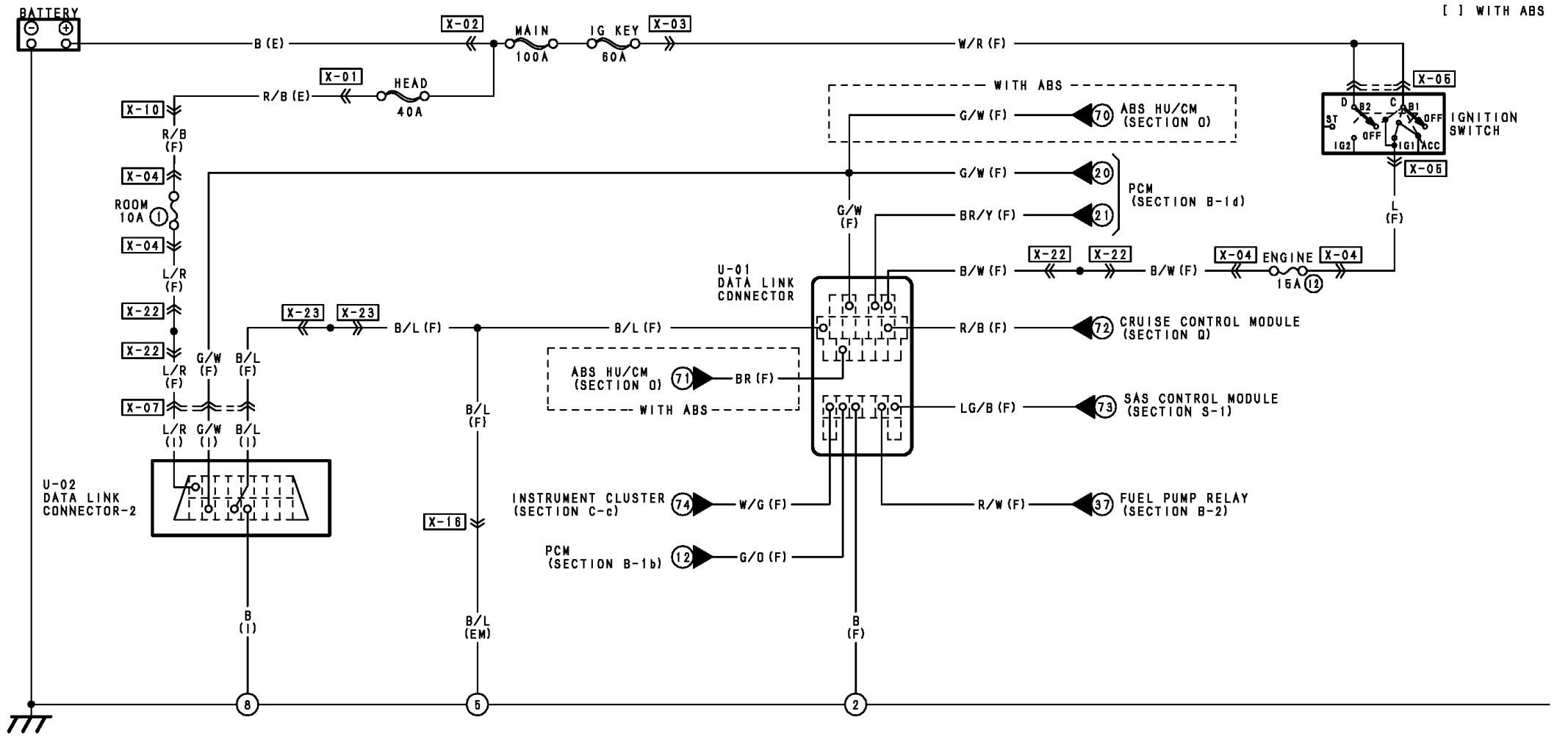

U-01 DATA LINK CONNECTOR (F)

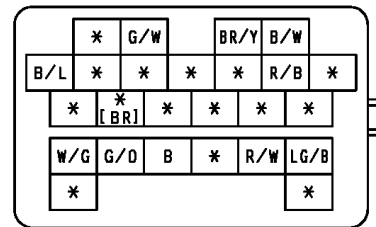
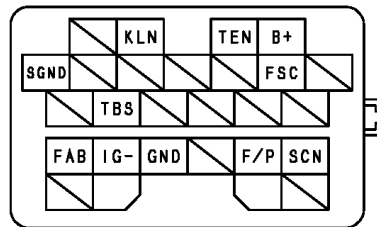

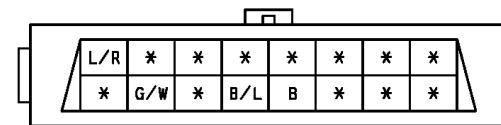

NOTE: THIS IS THE CONNECTOR AS SEEN FROM THE TERMINAL SIDE.

U-02 DATA LINK CONNECTOR-2 (I)



NOTE: THIS IS THE CONNECTOR AS SEEN FROM THE TERMINAL SIDE.

HARNESS SYMBOL :  (F)  (E)  (R)

# Data Link Connectors \ U

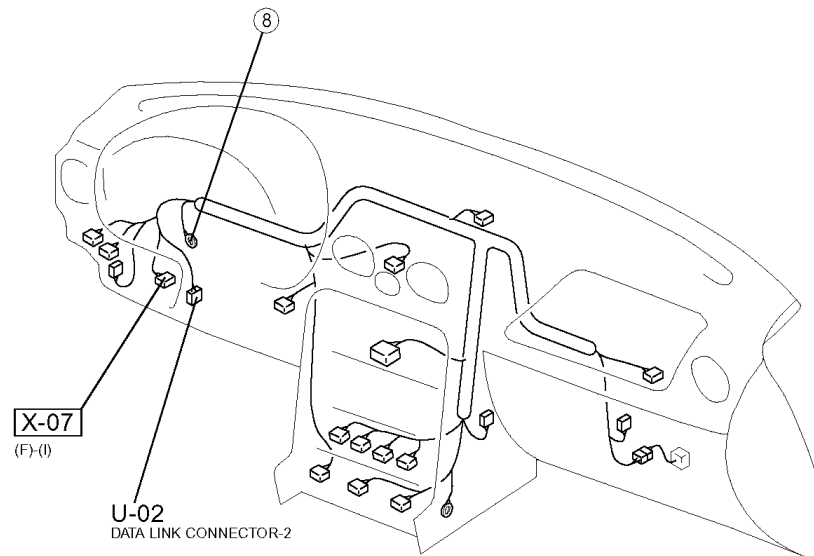
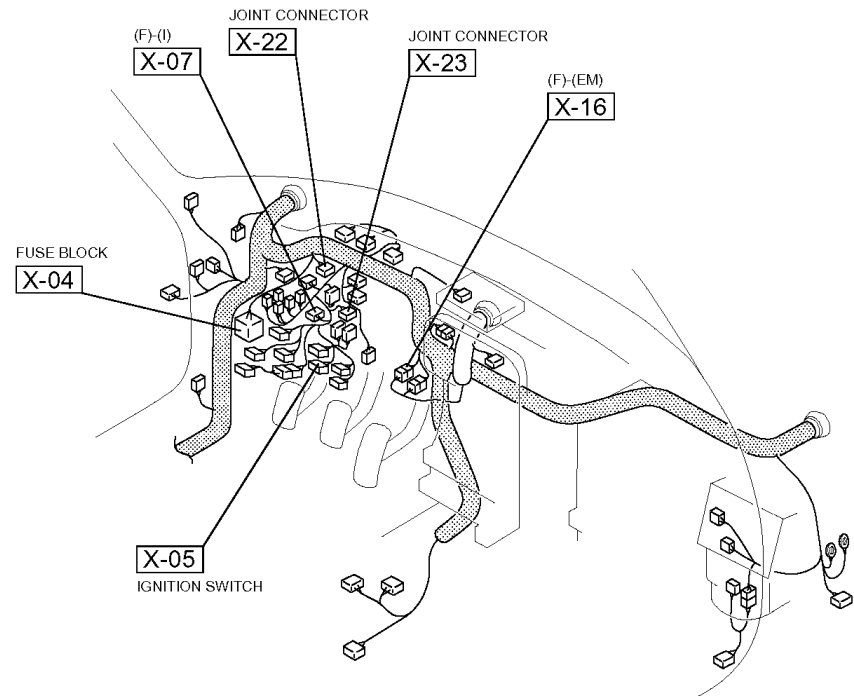
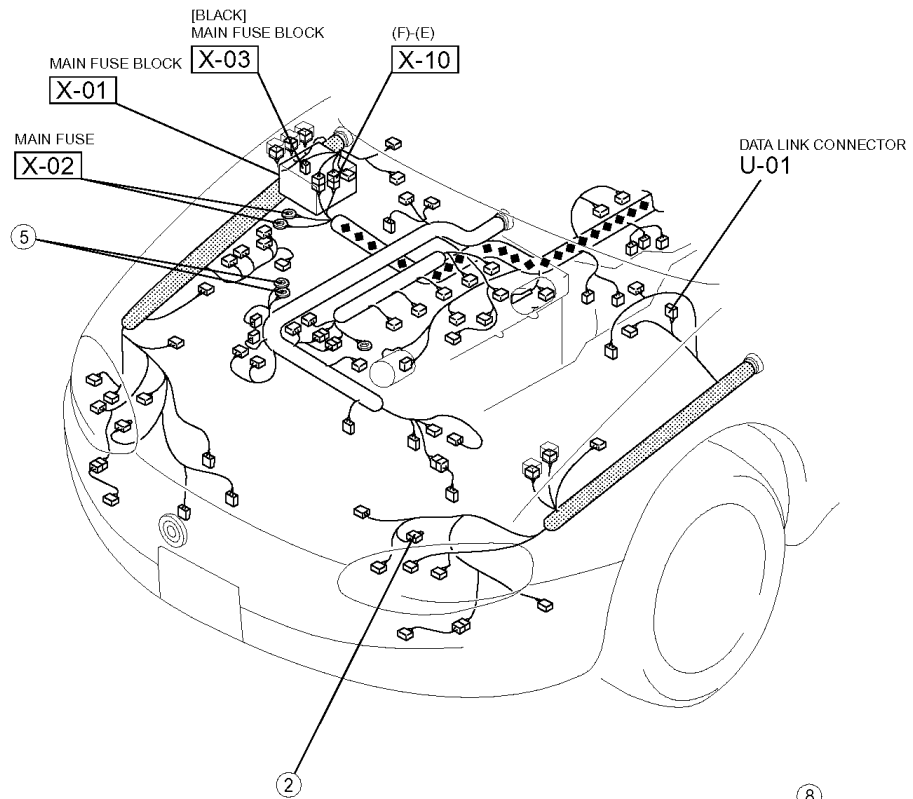

# Common Connector List \ X-1

X-01 MAIN FUSE BLDC (E)

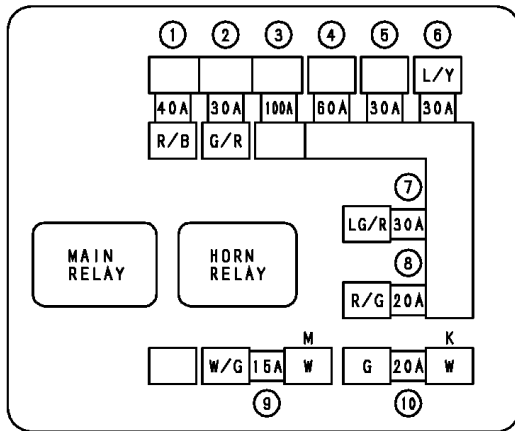

- 1: HEAD
- 2: FUEL INJ
- 3: MAIN
- 4: IG KEY
- 5: BLOWER
- 6: FAN
- 7: BTN1
- 8: BTN2
- 9: STOP
- 10: ABS

NOTE: THIS IS THE CONNECTOR AS SEEN FROM THE TERMINAL SIDE.

X-02 MAIN FUSE (E)

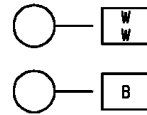

X-03 MAIN FUSE BLOCK (F)

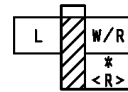

< > WITH ABS

X-04 FUSE BLOCK (F)

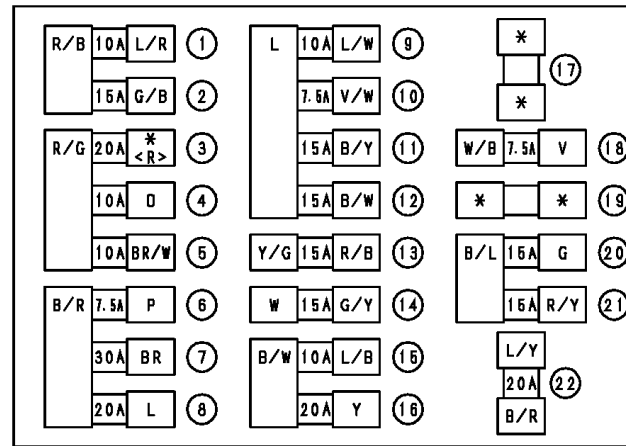

NOTE: THIS IS THE CONNECTOR AS SEEN FROM THE TERMINAL SIDE.

< > BOSE AUDIO

- 1: ROOM
- 2: DEFOG
- 3: AUDIO
- 4: D. LOCK
- 5: HAZARD
- 6: A/C
- 7: P. WIND
- 8: WIPER
- 9: A/B
- 10: TURN
- 11: METER
- 12: ENGINE
- 13: TAIL
- 14: F. FOG
- 15: RADIO
- 16: CIGAR
- 17: -
- 18: ST. SIG
- 19: -
- 20: HEAD RH
- 21: HEAD LH
- 22: AD FAN

X-05 IGNITION SWITCH (F)

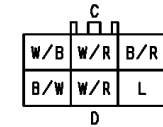

X-06 FRONT (F) - INSTRUMENT PANEL (I)

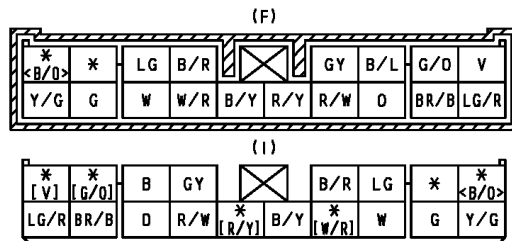

[ ] WITH KEYLESS ENTRY SYSTEM < > BOSE AUDIO

X-07 FRONT (F) - INSTRUMENT PANEL (I)

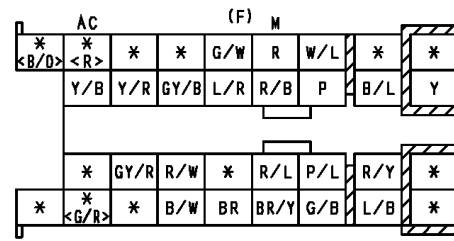

[ ] WITH KEYLESS ENTRY SYSTEM

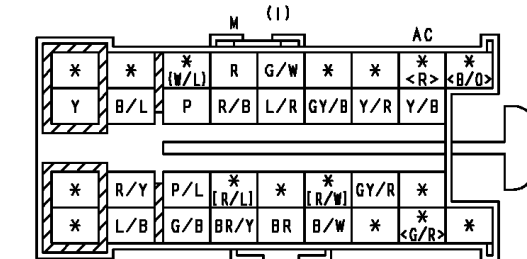

[ ] WITH CRUISE CONTROL SYSTEM < > BOSE AUDIO

X-08 FRONT (F) - REAR (R)

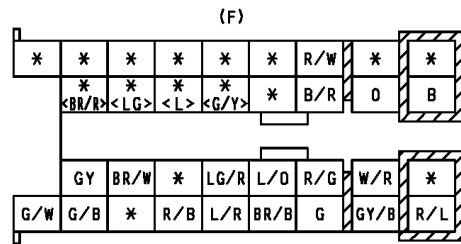

X-08 FRONT (F) - REAR (R)

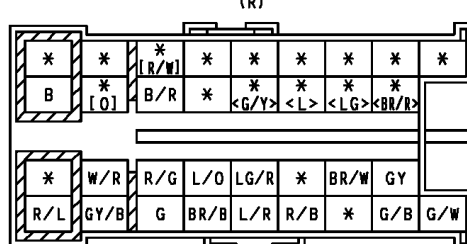

[ ] WITH KEYLESS ENTRY SYSTEM < > WITH ABS

X-09 FRONT (F) - ENGINE (E)

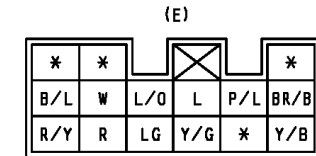
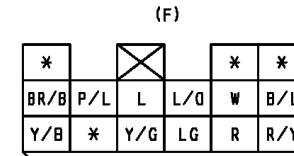

(AT)

X-10 FRONT (F) - ENGINE (E)

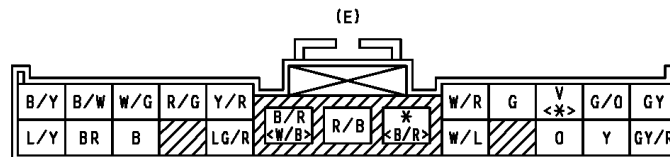
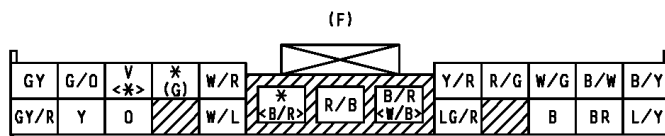

[ ] WITH ABS < > AT

X-11 FRONT (F) - INTERIOR LIGHT (IN)

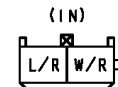
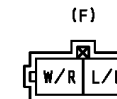

# Common Connector List \ X-2

