

DIYPNP Installation Guide

4/5/2016 v2.1



Things you'll need to have to install DIYPNP:

Serial to USB cable
6' of vacuum line
Vacuum tee
Timing light
Laptop
WBo2

Tools you may need:

10mm socket
Pliers
Razor/scissors

What's in the box:



Assembled and configured diyautotune.com DIYPNP unit
DB15 pigtail for inputs/outputs (page 5)
GM AIT sensor kit
EBC Boost Solenoid (optional)
Unused parts during assembly (not pictured)

Wiring Your Megasquirt (MS):

1.6L:

Your ECU is located under the passenger foot rest. Remove the side sill with a Phillips head screw driver and pull the carpet back, the cover can be lifted off after removing (5) 10mm nuts.



1.8L:

Your ECU is located behind the passenger seat. Remove the side sill with a Phillips head screw driver and pull the carpet back, off the ECU. The ECU can be lifted off after removing 3 10mm nuts.



Remove the ECU, plug the OEM connectors into your new harness and attach the DB37 connector to your MS (be certain to screw in the connector).

99-05

Your ECU is under the dash next to the steering column. The singular Motorsports mounting bracket is recommended for NB installations.

See: <http://www.good-win-racing.com/Mazda-Performance-Part/61-1587.html>

Air Intake Temp (AIT) Sensor / Fuel Pump / EBC solenoid

The MS harness is wired so hooking up the AIT sensor, activating the fuel pump (1.6L only), and EBC is very easy and without the need to splice, crimp, or solder.

With the provided wire in the AIT bundle, wire your new GM AIT sensor by pushing the spade connectors directly into the AFM/MAF harness. Polarity doesn't matter.

1.6L owners will have a provided length of wire they can use to jump the two pins for the fuel pump. This connects to the MS to the fuel pump relay so it can control the fuel pump properly.

1.6L owners will have to connect the solenoid to a switched power supply inside the engine bay. The blue power connector is the ideal choice. See *below*.

1.6L AFM Connector

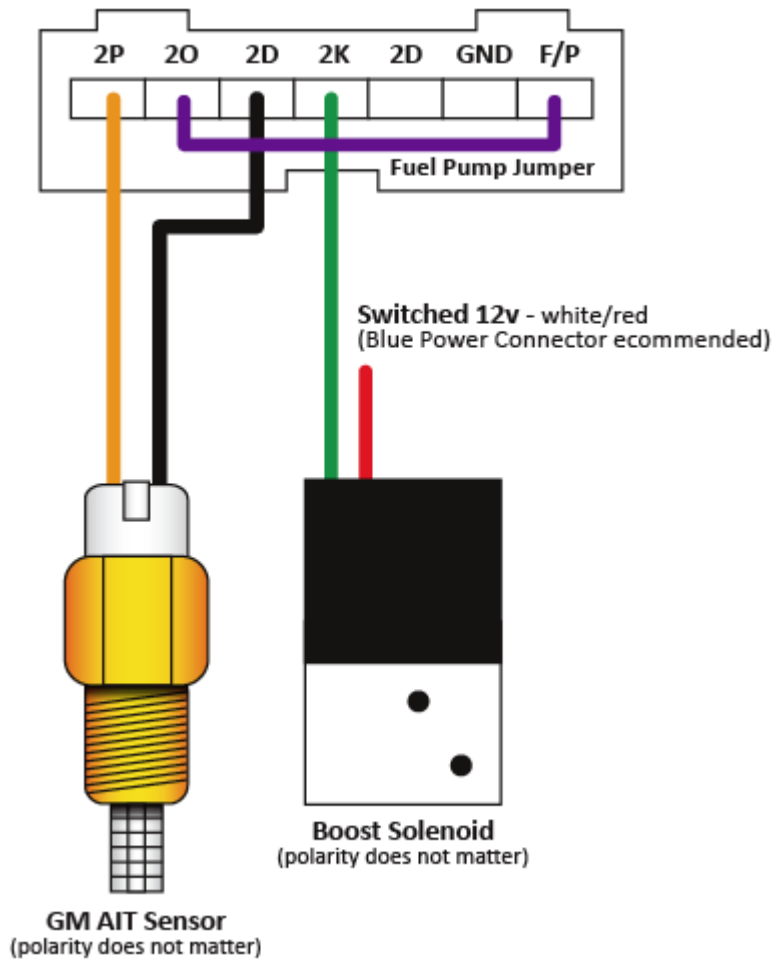

1.8L NA MAF Connector

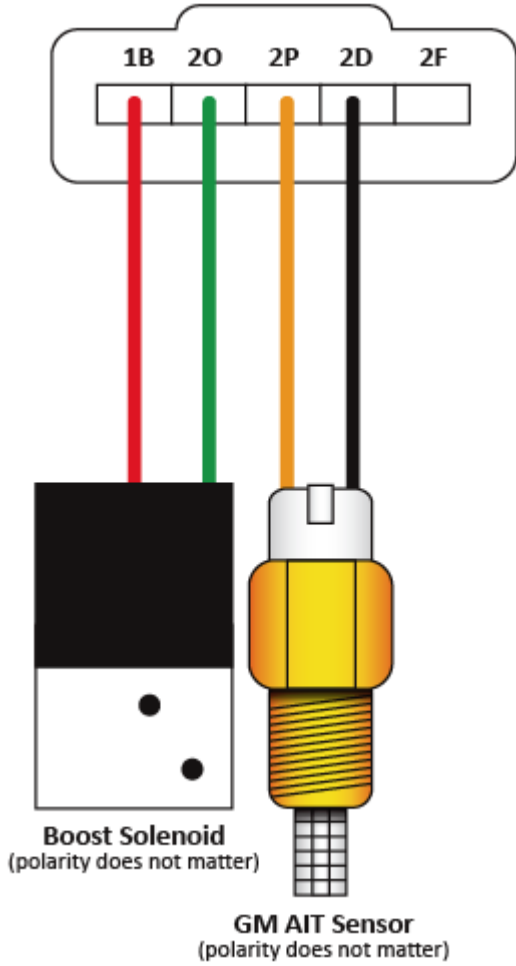

1.8L NB & NB2 MAF Connector

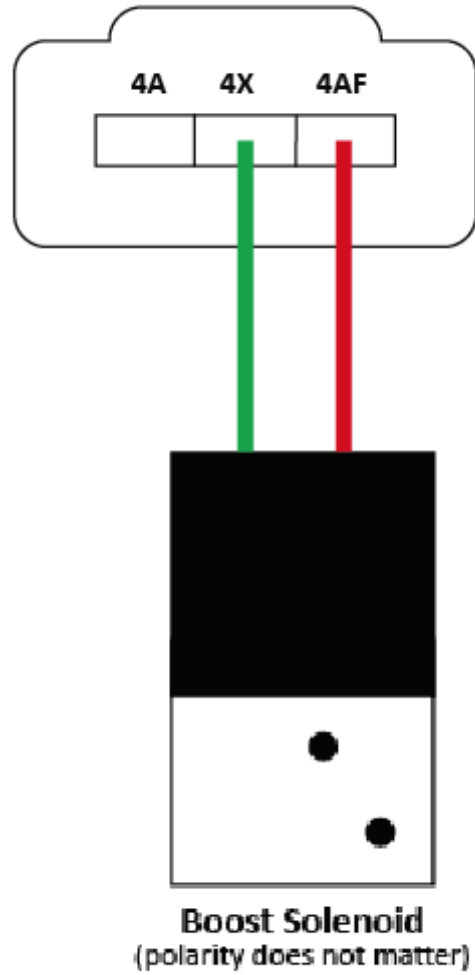

99-05: Your AIT sensor is located behind the MAF on the intake pipe, unplug it and use that connector in the same fashion as the above.

Installation note: *Fold the wires over the side of the connector and then wrap it a few times with electrical tape to prevent them from pulling out; tuck away under the brake booster.*

WBO2:

Your DB15 connector is prewired to power your WBo2 Controller and accept your WBo2 input.

Wire:

Power to pin 1.

Ground to pin 2.

WB Output to pin 4. (Yellow wire on LC1/2/MTX-L)

DB15 Connector

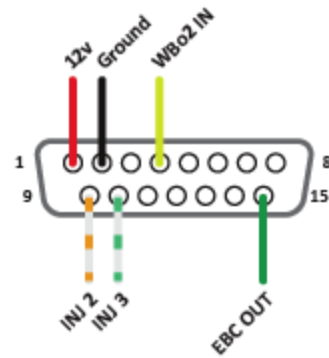

Installation Note: If your DB15 has additional wires on it please refer to the pinout on the right.

Powering a Boost Solenoid (1.6L only):

Connect one wire of the solenoid to the little blue +12v connector near the driver headlight (it has a cap on it, when you pull it off it's just a little spade), or any or other switched/fused +12volt power source in the engine bay (white/red).



The Blue Power Connector is the easiest to use as you'll most likely be mounting it there anyway.

Plumbing a Boost Solenoid:

The boost goes into the lower port on the side with two ports. The exhaust to the wastegate is on the side with only one port. This should be labeled.

The best boost source would be between the intercooler and throttle body. It is not recommended to source boost from the intake manifold because the vacuum can

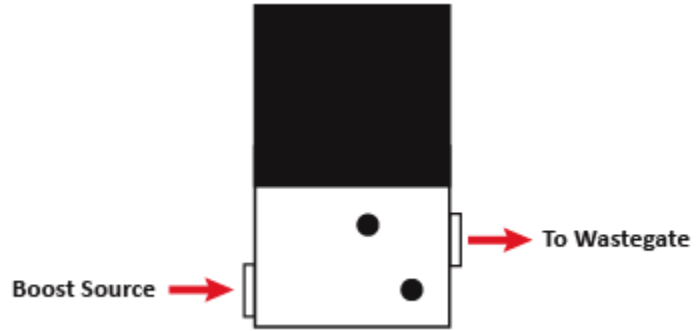

potential damage the wastegate or cause issues. Sourcing boost from the turbo is the easiest.

MAP SENSOR:

Run a vacuum line from your intake manifold to the MAP sensor inside MS. The ideal spot is teeing off the FPR on the back of the manifold. If you use a different port the map signal tends to spike when it shouldn't due to turbulence.



There is a grommet on the firewall you can pass the vacuum line through. Pop it out, drill a hole to fit the vacuum line through, and start feeding it in. You'll need to reach up behind the insulation and glove box to find it.

TPS:

*****1.6L users YOU MUST DISCONNECT your stock TPS connector*****

Failure to disconnect the TPS will result in the MS unable to connect to laptop and start the car.

The stock TPS sensor is just an On/Off switch and the MS cannot do anything with the signal.

Your harness is prewired to work in conjunction with a vTPS (like the Wells TPS201 mod as outlined on miataturbo.net) or automatic throttle body. Wiring it this way gives you an easy upgrade opportunity: allowing you to use TPSdot enrichments instead of MAPdot.

See: <http://www.miataturbo.net/forum/t12239/#post157397>

To install a vTPS simply connect to the stock TPS harness as follows:

Function	OE Wire Color
TPS Signal	Lt. Green / White
Ground	Black / Green
5v	Red

Installation Note: You will also need to remove the resistor jumping 4L and 4D within the DIYPNP unit when upgrading. Failure to remove this resistor will prevent the vTPS from reading.

How to wire a 1.8L throttle body to the 1.6L harness:

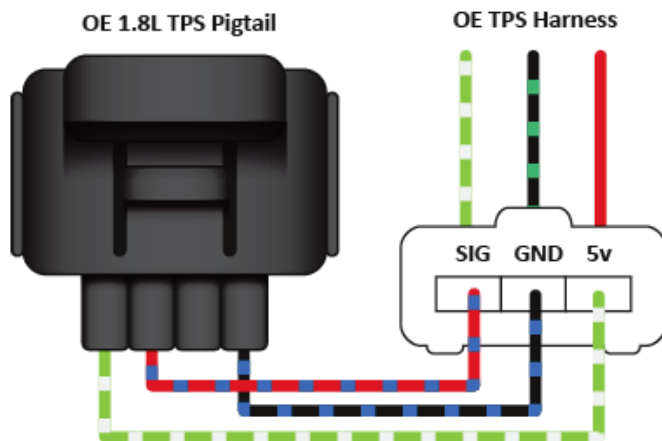

NOTE: IF YOU DON'T HAVE A TACH SIGNAL ON YOUR DASH (90-95):

Use a spare 1K resistor from your package and jump IG- and B+ in your diagnostics box. Shaped it into a wide "U" and trim the legs down so it fits inside the cover. Make sure it doesn't touch any other pins -- B+ connects directly to the battery.

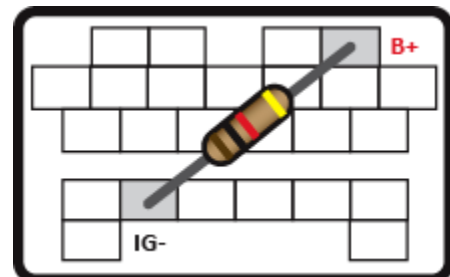

DONE WITH THE HARDWARE, ONTO THE SOFTWARE.

Once you've finished the external DIYPNP wiring and have connected the factory harness to the MS harness, connect your serial to usb cable to your MS, and power up the unit (key ON). You should hear the fuel pump activate.

Make sure the usb>serial drivers install properly and your computer assigns the cable a com port.

If you cannot get past this stage, contact me before continuing.

Software Setup:

Download the latest release of Tuner Studio software.

<http://www.tunerstudio.com/index.php/downloads>

NOTE: *It is highly recommended that you pay to register the product. This gains you access to VE Analyze LIVE which can autotune your fuel map.*

To start, go to the file menu, and select **New Project**.

Under the pull up menu in Projects, you will be given a few choices related to the project. Since you want to set up for your car, the first thing you want to do is SELECT NEW PROJECT.

This screen should open up:

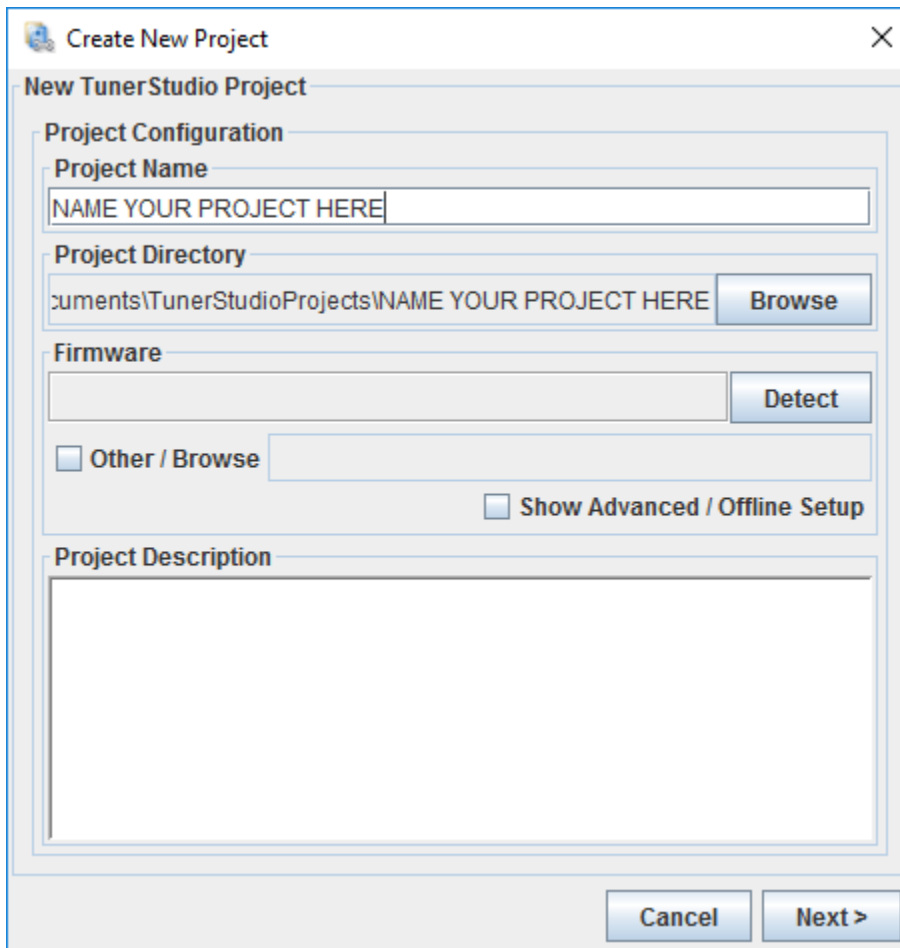

The screenshot shows a Windows-style dialog box titled "Create New Project" with a close button (X) in the top right corner. The dialog is divided into several sections:

- New TunerStudio Project**: The main title of the dialog.
- Project Configuration**: A section containing:
 - Project Name**: A text input field with the placeholder text "NAME YOUR PROJECT HERE".
 - Project Directory**: A text input field showing a path "uments\TunerStudioProjects\NAME YOUR PROJECT HERE" and a "Browse" button to the right.
 - Firmware**: A text input field and a "Detect" button to its right.
 - Other / Browse**: A checkbox followed by a text input field.
 - Show Advanced / Offline Setup**: A checkbox.
- Project Description**: A large, empty text area for entering details about the project.

At the bottom of the dialog, there are two buttons: "Cancel" and "Next >".

Name the project something that you can easily identify, and make it specific. For example, "My DIYPNP Project" you can name it whatever you like, it doesn't really matter.

Make sure under "Project Directory," to save it to the Tuner Studio Projects Folder, which should default in your My Documents folder. Otherwise on some Vista and 7 machines, you may have issues saving files.

Next, you need to select the firmware you will be using. With the MS unit installed and powered with key ON, click **DETECT**.

The software should find your MS3x unit, and determine the firmware. Hit **Accept**. You *may* be prompted to download the firmware file locally, so you'll need an internet connection if prompted.

On the next page, choose your Configuration settings. Choose your WB choice, Temperature Display settings, and match the rest like the right:

On the next page, the software will test the connection to your MS3X, so make sure the MS remains ON:

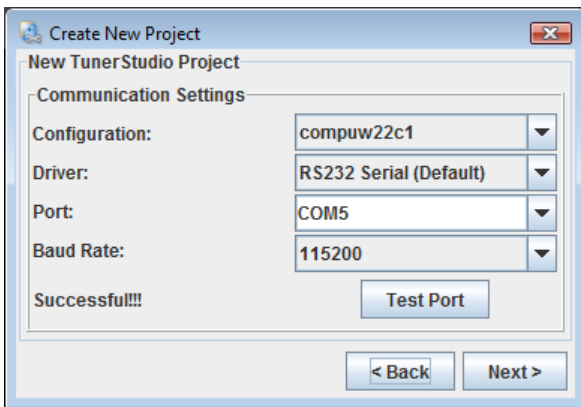

If you don't have a "Successful!!!" message like above, please contact me.

Click **next** and select the default dashboard, you must register the program (which you should) in order to change the display.

When you hit **Okay**, the software should connect to the MS3x and you should see data on the gauges on the digital dashboard.

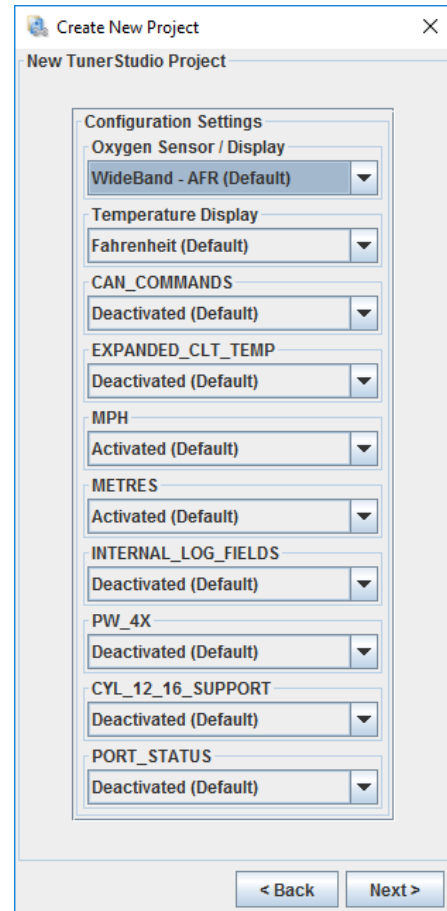

Configuring your Sensors

Under Tools > Calibrate TPS

- With your foot OFF the throttle, click 'GET CURRENT' for the Closed Throttle ADC Count
- Floor it and hold it there. Click 'GET CURRENT' for the Full Throttle ADC Count
- Click Close

Calibrate your CLT Sensor and IAT Sensor.

- Again from TunerStudio, click 'Tools > Calibrate Thermistor Tables'. Make sure 'Coolant Temperature Sensor' is selected at the top.

For the 90-97 CLT, use "RX7_CLT (S4 & S5)" from the common sensor values.

For the 99-05 CLT, use the following table with a bias resistor setting of 2490 ohms:

Temperature	F / C	Resistance In Ohms
14 / -10		9000
68 / 20		2500
176 / 80		320

- Enter these values, and click 'Write to Controller'.

Select 'Intake Temperature Sensor' at the top in the drop down box.

- For the GM IAT sensor, select GM from the "common sensor values" and click 'Write to Controller'. Now click Close to Exit.

Finally, you should calibrate your O2 Sensor to the ECU.

To do this, click 'Tools > Calibrate AFR Table'.

- Choose your O2 Sensor from the list. Choose Narrowband for the stock O2 Sensor. Or select your wideband and the proper configuration of said wideband from the drop-down list. If you are using an LC-1 or MTX-L, try using .23v – 7:35 and 5v – 22.39:1.
- Click 'Write to Controller'. Once finished writing, click 'Close'.

Now click 'Tools > Un/Lock Calibrations' and change the sensors from unlocked to locked, then click burn and close.

Configuring your tune:

Once you start the car, the first thing you have to do it match the ignition timing! MS has no idea what your timing is so driving on your new ECU without doing this is potential for serious failure.

Start and idle the car and allow it to warm-up and stabilize.

Open up Basic Setup > More Ignition Options.

To adjust the timing you adjust the trigger angle, that's it. No more rotating the CAS, this is same concept.

Change the "Fixed Advance" from 'Use table' to 'Fixed Timing', then make sure 'Timing for Fixed Advanced' is set to "10.0". By doing this, you're telling your Megasquirt to hold the ignition timing at 10° no matter what. This is essentially what you are doing when you would jump GND and TEN in the past. Since MS has control of your timing now, this is how you can lock the timing.

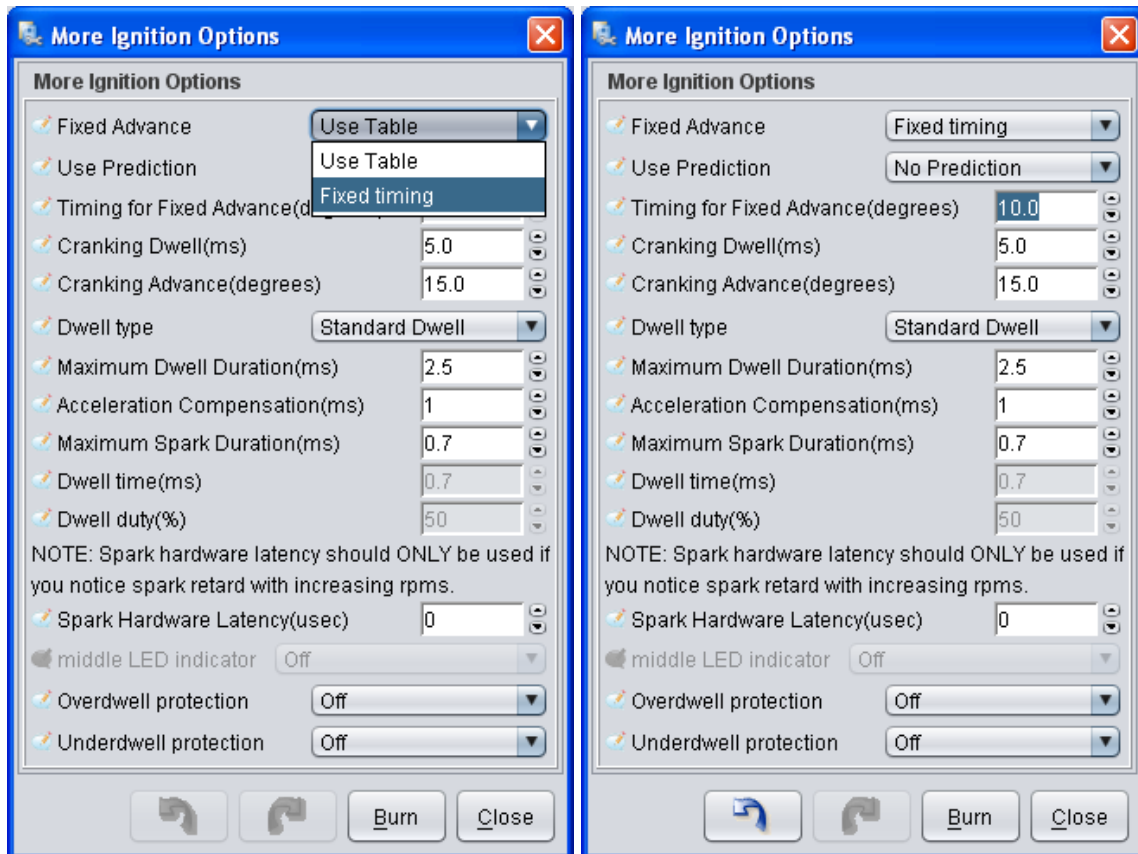

Use your timing light and verify the timing is correct. The timing mark should land on 10°. If it's not a match, change the *trigger angle* a few points and try again.

Go to Tools > Trigger Wizard



Click + or – until your timing mark lines up to 10°. Once your timing light indicates 10° you have now synced the CAS position and the MS.

Back in “More Ignition Options”

Let's make sure your spark hardware latency is configured. You can see by default it's set to 0. You can verify by locking ignition timing 10°, which it should still be and then slowly running the engine from idle to 6,000 RPM while observing with a timing gun. If the spark tends to retard as RPM goes up, you need to add latency correction until it stays at 10°. This will prevent your timing from dropping in higher rpms.

Now, change the “Fixed Angle” back to “Use Map”. If you fail to do this, your timing will remain at 10° regard of RPM or load; this will overheat your motor fast and run very sluggish. If you go back out with a timing light you should see you're probably idling in the 15-18° range.

That's it! You're now ready to tune this baby up. You changed your timing back to “use map” right?

Your spark table, by default, is a good conservative table; so focus on fuel.

Go to basic setting > VE Table 1

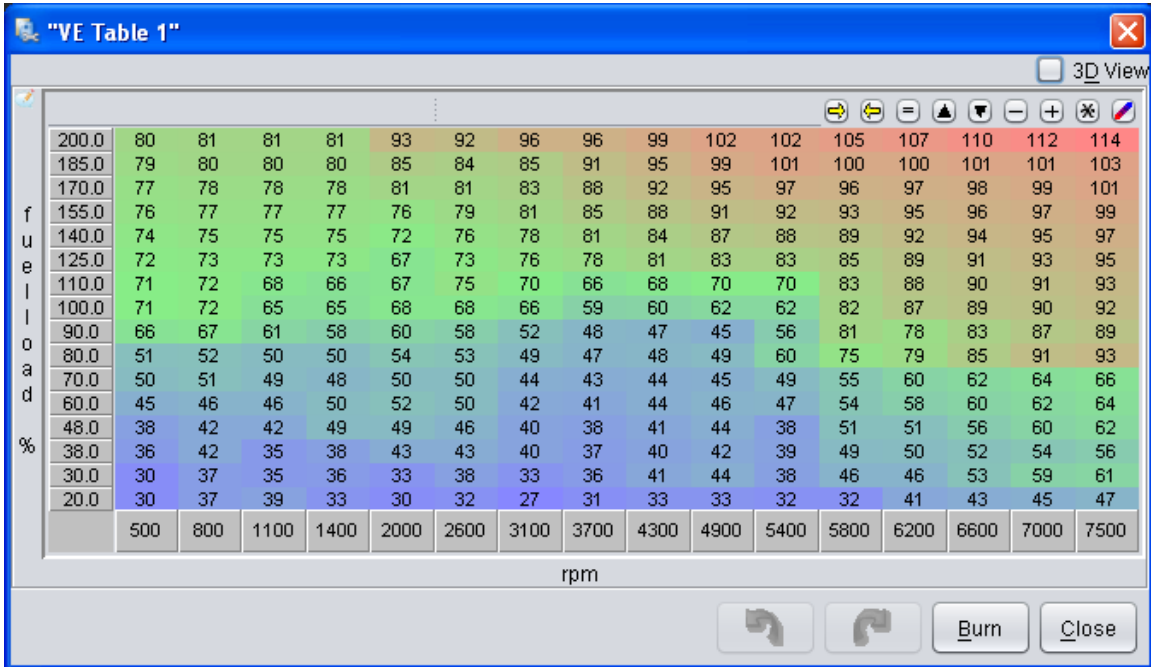

That's the fuel map, when idling you can see where it's reading the map at. When you drive you can see your AFR gauge react to whatever situation your map is in. Adjust as needed. It should be close...you might have to increase the table by 5-10 point throughout to idle good.

If you highlight cell you can plug numbers in on the top. If you want to increase by 5 points, highlight the cells you want, hit the plus sign, and then enter in a value.

"VE Table 1" 3D View

200.0	80	81	81	81	93	92	96	96	99	102	102	105	107	110	112	114
185.0	79	80	80	80	85	84	85	91	95	99	101	100	100	101	101	103
170.0	77	78	78	78	81	81	83	88	92	95	97	96	97	98	99	101
155.0	76	77	77	77	76	79	81	85	88	91	92	93	95	96	97	99
140.0	74	75	75	75	72	76	78	81	84	87	88	89	92	94	95	97
125.0	72	73	73	73	67	73	76	78	81	83	83	85	89	91	93	95
110.0	71	72	68	66	67	75	70	66	68	70	70	83	88	90	91	93
100.0	71	72	65	65	68	68	66	59	60	62	62	82	87	89	90	92
90.0	66	67	61	58	60	58	52	48	47	45	56	81	78	83	87	89
80.0	51	52	50	50	54	53	49	47	48	49	60	75	79	85	91	93
70.0	50	51	49	48	50	50	44	43	44	45	49	55	60	62	64	66
60.0	45	46	46	50	52	50	42	41	44	46	47	54	58	60	62	64
48.0	38	42	42	49	49	46	40	38	41	44	38	51	51	56	60	62
38.0	36	42	35	38	43	43	40	37	40	42	39	49	50	52	54	56
30.0	30	37	35	36	33	38	33	36	41	44	38	46	46	53	59	61
20.0	30	37	39	33	30	32	27	31	33	33	32	32	41	43	45	47
	500	800	1100	1400	2000	2600	3100	3700	4300	4900	5400	5800	6200	6600	7000	7500
	rpm															

Burn Close

Tuning:

Setup your AFR target.

Turn EGO Control on. Step size 1% will allow the ECU to make on the fly adjustments based of your AFR reading to try to match your AFR targets table. You can change the speed it reacts (events per step), how much it can change your table numbers (Auth) and other parameters.

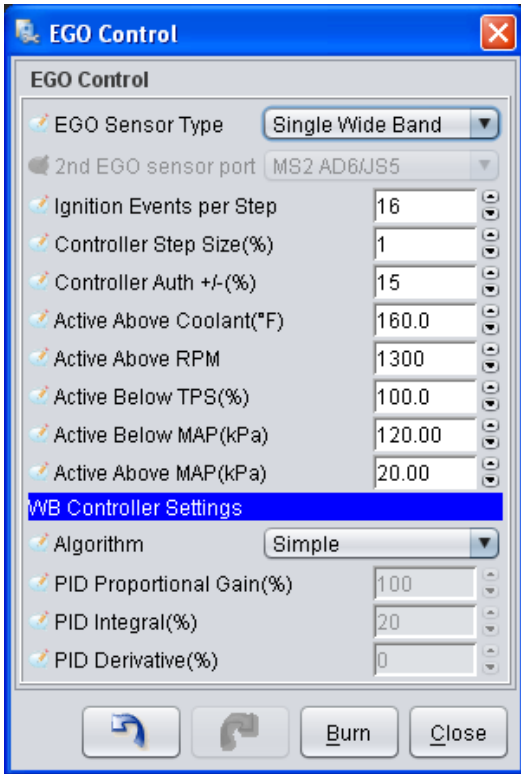

Then go to Basic Settings > AFR table 1 – Setup your AFR targets how you'd like, these are my defaults.

	500	800	1100	1400	2000	2600	3100	3700	4900	5000	5600	7200
200.0	11.5	11.5	11.5	11.5	11.5	11.5	11.5	11.5	11.5	11.5	11.5	11.5
187.0	11.6	11.6	11.6	11.6	11.6	11.6	11.6	11.6	11.6	11.6	11.6	11.6
175.0	11.8	11.8	11.8	11.8	11.8	11.8	11.8	11.8	11.8	11.8	11.8	11.8
145.0	12.2	12.2	12.2	12.2	12.2	12.2	12.2	12.2	12.2	12.2	12.2	12.2
120.0	12.6	12.6	12.6	12.6	12.6	12.6	12.6	12.6	12.6	12.6	12.6	12.2
100.0	14.7	14.7	14.7	14.7	14.7	14.7	14.7	14.7	14.7	14.7	14.7	12.6
95.0	14.7	14.7	14.7	14.7	14.7	15.5	15.5	15.5	15.5	15.5	15.5	12.6
87.0	14.7	14.7	14.7	14.7	14.7	15.5	15.5	15.5	15.5	15.5	15.5	12.6
75.0	14.7	14.7	14.7	14.7	14.7	15.5	15.5	15.5	15.5	15.5	15.5	12.6
60.0	14.7	14.7	14.7	14.7	14.7	15.5	15.5	15.5	15.5	15.5	15.5	12.6
45.0	14.7	14.7	14.7	14.7	14.7	15.5	15.5	15.5	15.5	15.5	15.5	12.6
30.0	14.7	14.7	14.7	14.7	14.7	14.7	14.7	14.7	14.7	14.7	14.7	12.6

These are the AFR targets you're telling the MS you want to hit.

If you click the VE Analyze Live tab, TunerStudio software can autotune your fuel map based off your AFR targets while you drive, this will be the quickest way to get your map tuned to your setup.

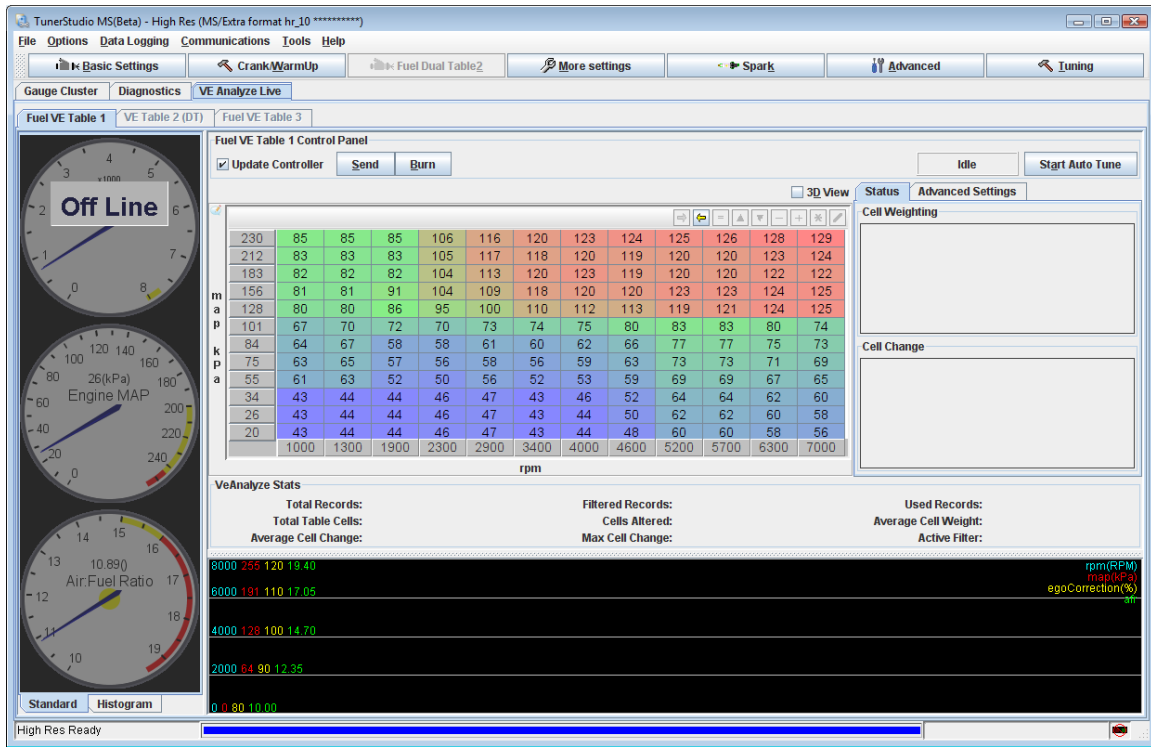

Please visit: <http://www.miataturbo.net/forum/t42925/?highlight=tunerstudio> for more discussion on tuning with VE Analyze Live.

To record logs go to Datalogging > Start Logging.

Go out for a cruise once you get the fuel relatively close. And record the session.

Final note: your over boost protection might kick in if you hit boost lower than the threshold, so you might need to change that as well. I have it set low just in case.

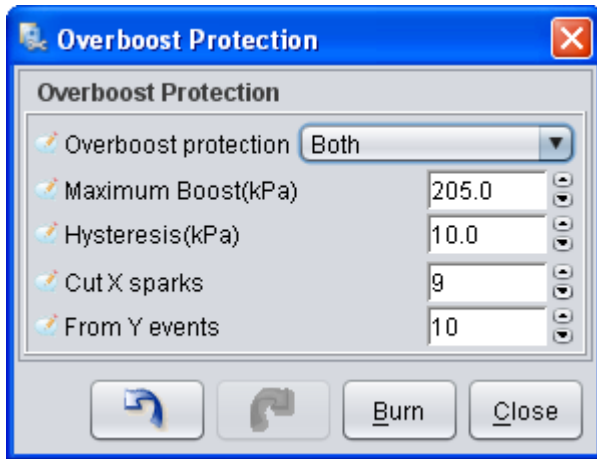

Go to megasquirtnp.com and read through their articles on tuning and installation for better help.

Msextra.com is a great forum for MS specific questions.

And of course the miataturbo.net megasquirt forum.