

Mazda
MX-5 *miata*
MX-5

2003 Wiring Diagram

FOREWORD

This wiring diagram incorporates the wiring schematics of the basic vehicle and available optional equipment. Actual vehicle wiring may vary slightly depending on optional equipment or local specifications, or both. All information in this booklet is based on information available at the time of printing. Mazda Motor Corporation reserves the right to make changes without previous notice.

Mazda Motor Corporation
HIROSHIMA, JAPAN

APPLICATION:

This manual applies to vehicles beginning with the Vehicle Identification Numbers (VIN) on the following page.

CONTENTS

TITLE	Section
GENERAL INFORMATION OF WIRING DIAGRAMS	GI
GROUND POINTS	Y
ELECTRICAL WIRING SCHEMATIC	W
SYSTEM CIRCUIT DIAGRAM/ CONNECTOR LOCATIONS	A-U
COMMON CONNECTORS	X
PARTS INDEX	PI

**VEHICLE IDENTIFICATION NUMBER (VIN)
(CHASSIS NUMBER)**

**JM1 NB353*0# 300001—
JM1 NB353*3# 300001—**

WIRING COLOR CODE

COLOR	CODE	COLOR	CODE
BLACK	B	LIGHT GREEN	LG
BLUE	L	ORANGE	O
BROWN	BR	PINK	P
DARK BLUE	DL	RED	R
DARK GREEN	DG	SKY BLUE	SB
GRAY	GY	VIOLET	V
GREEN	G	WHITE	W
LIGHT BLUE	LB	YELLOW	Y

SYSTEM INDEX

GENERAL INFORMATION	2	EXTERIOR LIGHTING SYSTEM	
GROUND POINT	12	HEADLIGHT	
ELECTRICAL WIRING SCHEMATIC	14	WITHOUT DRL	38
ENGINE-RELATED SYSTEM		WITH DRL	40
CHARGING SYSTEM	16	FRONT SIDE MARKER LIGHT	42
STARTING SYSTEM	16	LICENSE PLATE LIGHT	42
ENGINE CONTROL SYSTEM	18	PARKING LIGHT	42
FUEL CONTROL SYSTEM	26	TAILLIGHT	42
COOLING FAN SYSTEM	28	FRONT FOG LIGHT	44
CHASSIS-RELATED SYSTEM		TURN AND HAZARD WARNING LIGHT	46
EC-AT CONTROL SYSTEM	52	BACK-UP LIGHT	48
KEY INTERLOCK SYSTEM	54	BRAKE LIGHT	48
SHIFT-LOCK SYSTEM	54	HIGH-MOUNT BRAKE LIGHT	48
ANTILOCK BRAKE SYSTEM	76	AIR CONDITIONING-RELATED SYSTEM	
CRUISE CONTROL SYSTEM	78	CONDENSER FAN SYSTEM	50
INSTRUMENT CLUSTER-RELATED SYSTEM		HEATER AND AIR CONDITIONER	50
INSTRUMENT CLUSTER	30	ACCESSORY	
BODY-RELATED SYSTEM		CIGARETTE LIGHTER	58
WINDSHIELD WIPER AND WASHER	36	AUDIO SYSTEM	
HORN	48	STANDARD AUDIO	64
REAR WINDOW DEFROSTER	58	BOSE AUDIO	66
KEYLESS ENTRY SYSTEM	62	POWER ANTENNA	68
TRUNK LID OPENER	62	OTHER	
POWER WINDOW SYSTEM	70	DATA LINK CONNECTOR	86
POWER DOOR LOCK SYSTEM	72	COMMON CONNECTOR LIST	88
POWER OUTSIDE MIRROR	74	PARTS INDEX	90
AIR BAG SYSTEM SERVICE CAUTION / SERVICE WARNING	80		
AIR BAG SYSTEM	82		
IMMOBILIZER SYSTEM	84		
INTERIOR LIGHTING SYSTEM			
TRUNK COMPARTMENT LIGHT	42		
ILLUMINATION LIGHT	56		
INTERIOR LIGHT	60		

Contents of wiring diagrams

- This document comprises the 6 groups shown below.

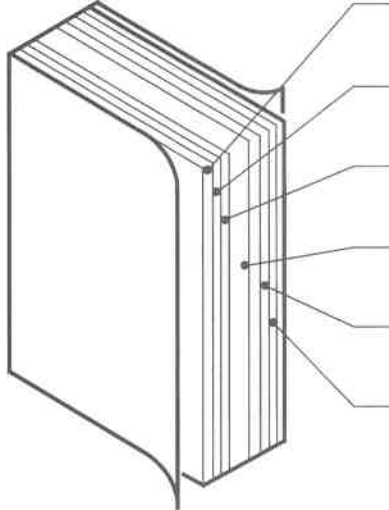

GI	General information of wiring diagrams	A how-to on using and reading wiring diagrams, using test equipment, checking harness and connectors, and finding trouble spots
Y	Ground points	Ground routes from and to the battery
W	Electrical wiring schematic	Shows main fuses and other fuses for each system
A-U	System circuit diagram/ connector locations	Shows circuit and connector diagrams and component and connector location diagrams
X	Common connectors	Shows connectors common throughout system
PI	Parts Index	Gives page number of circuit diagram for each component

System circuit diagram/connector diagram

- These diagrams show the circuits for each system, from the power supply to the ground. The power supply side is on the upper part of the page, the ground side on the lower part. The diagrams describe circuits with the ignition switch off.

Below is an explanation of the various points in the diagram.

System name

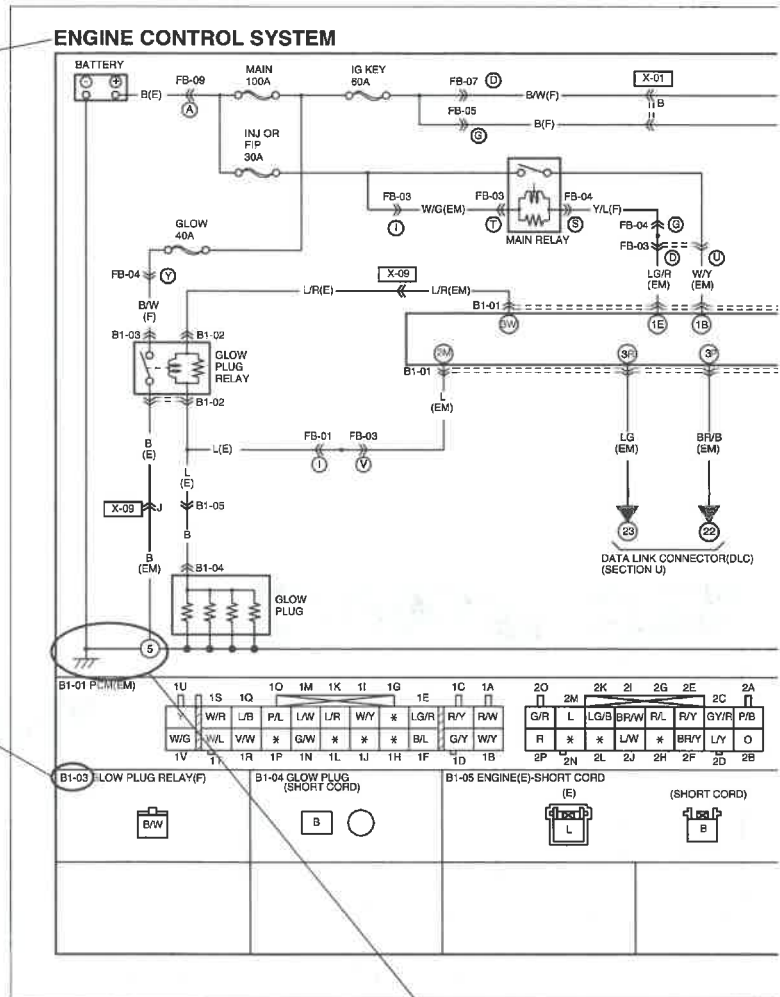

Connector code

The prefix letter indicates the system in which the connector is used.

- Y : Ground connector
- A : Charging system/starting system connectors
- B : Engine control system connectors
- C : Gauge control system connectors
- D : Wiper system connectors
- E : Lighting system connectors
- F : Signal system connectors
- G : Air-conditioning system connectors
- H : Transmission control/Key interlock/Shift-lock system connectors
- I : Interior light system connectors
- J : Audio/radio connectors
- K : Power window/power door lock system connectors
- L : Remote control mirror system connectors
- O : Anti-lock brake system connectors
- Q : Auto cruise control system connectors
- S : Passive shoulder belt control/Airbag system connectors
- T : Others
- U : Data link connector
- X : Common connectors

Ground numbers

A harness ground is represented differently than a unit ground.

Types of grounds	Symbol
<p>Harness</p>	
<p>Unit</p>	

System code

The number indicates that the circuit continues to the related system diagram.

Current symbol

Current flows in the direction of the arrow.

Indicates shielded wire.*

*Shielded wire :
Prevents signal disturbances from electrical interference.
Wire is covered by a metal meshing for grounding.

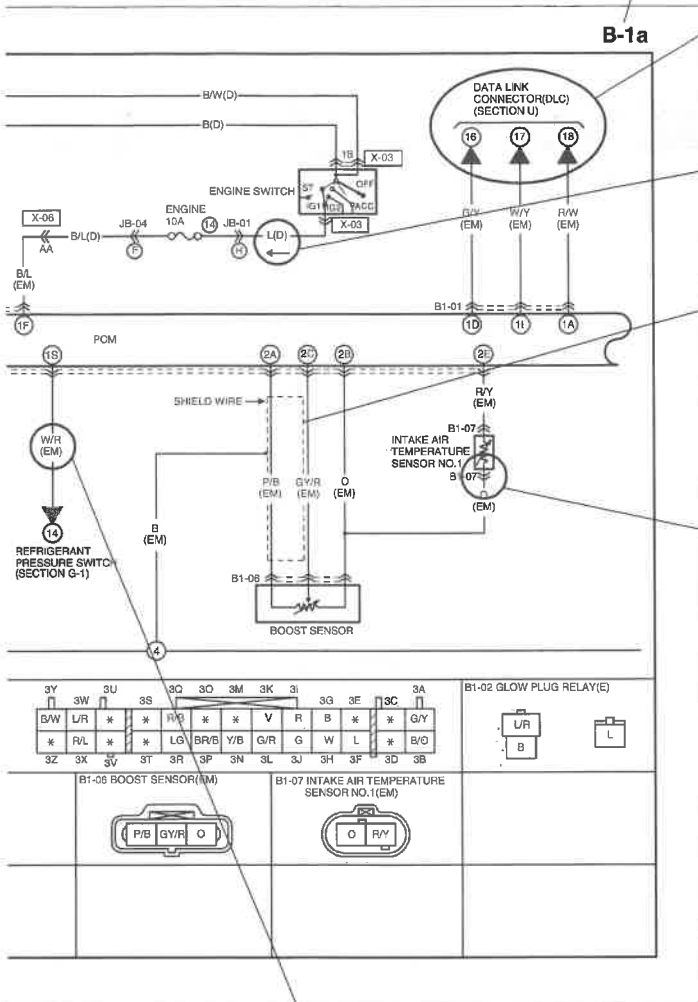

Connector symbols

- Male and female connectors are represented as follows in the circuit and connector diagrams.

		Circuit diagram symbol	Connector diagram symbol
Male			
Female			

- Like connectors are linked by dashed lines between the connector symbols.
- Connector diagrams show connectors on the harness side. The terminal indicates the view from the harness side.

(Example)

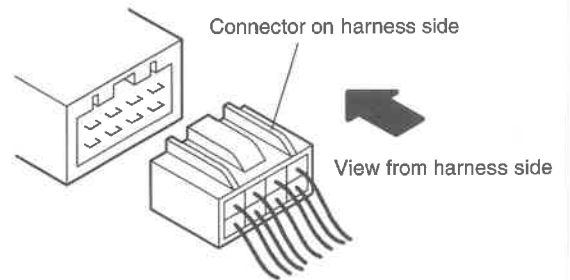

- Colors for connectors except white are given in locations.
- Unused terminals are indicated by *.

Wire color code (harness symbol)

- Two-color wires are indicated by a two-letter symbol. The first indicates the base color of the wire, the second the color of the stripe. For example:

W/R is a white wire with a red strip
BR/Y is a brown wire with a yellow strip

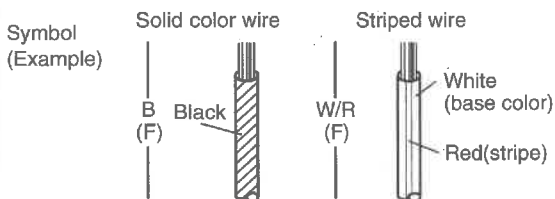

- The harness symbol is in () following the harness symbols (refer to P-7.).

Routing diagram

- The routing diagram shows where electrical components are on the system circuit diagram by call out line and connector symbols.

Connector symbol

Shows the system that uses the connector.

(Example)

Connector	Symbol
Common connectors	X-19
System connectors	I-03

Component name

Shows the names of components in routing diagrams.



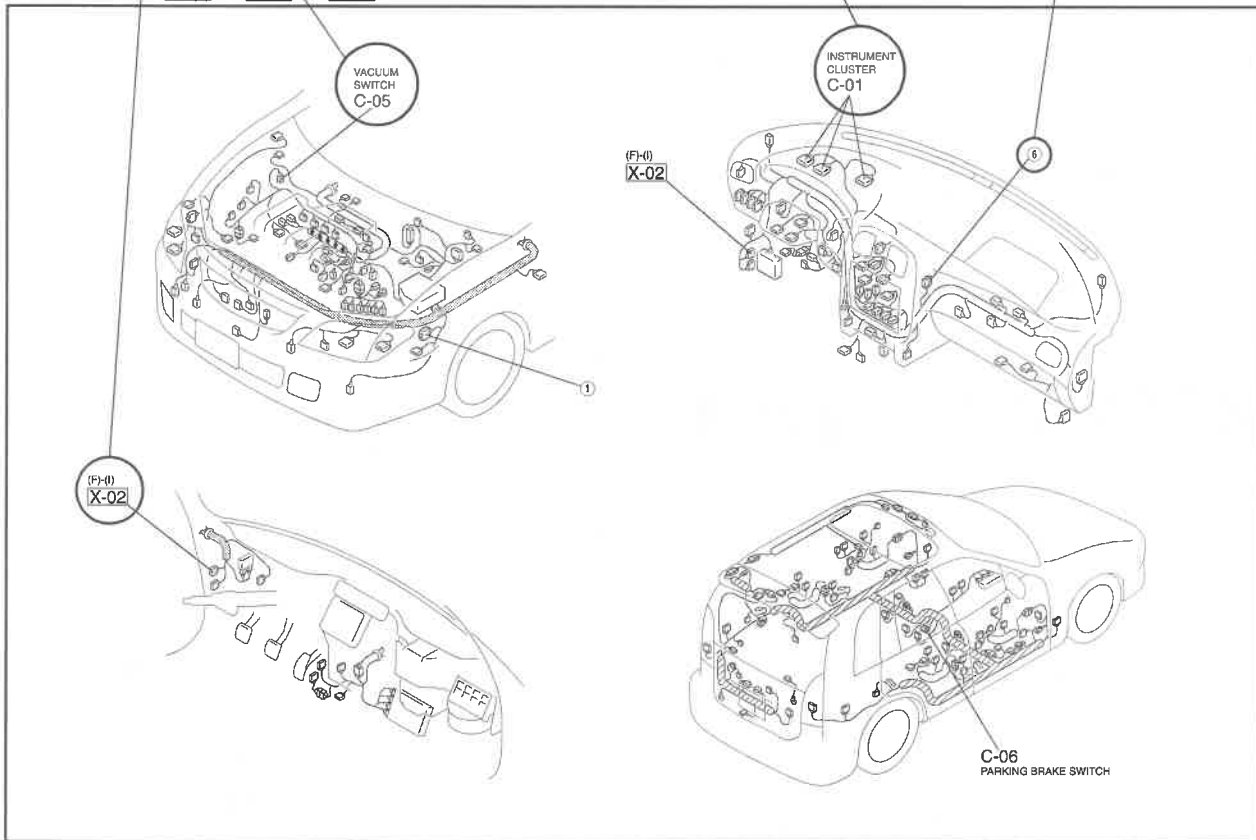

Ground symbol

Shows the ground in system diagrams.











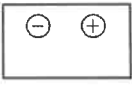

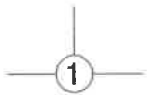

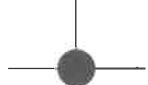
HARNESS SYMBOL :  (F)  (E)  (R)

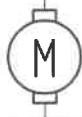
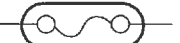

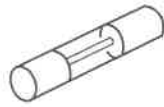
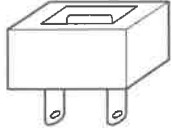
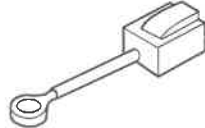
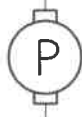

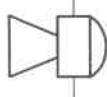
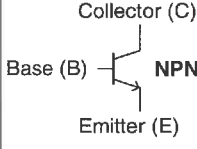
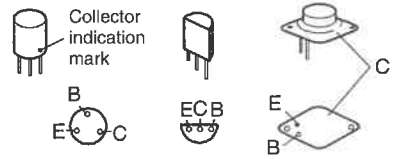

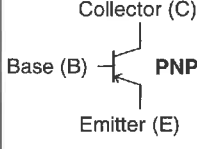
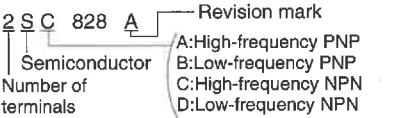

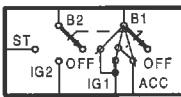

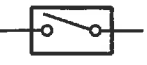

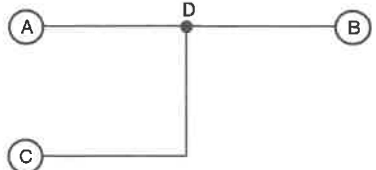
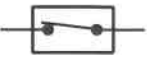
Harness symbols

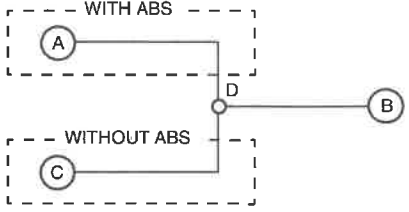
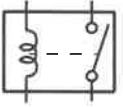
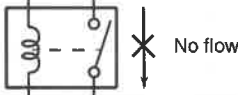
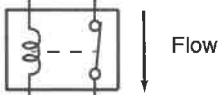
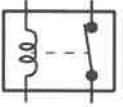
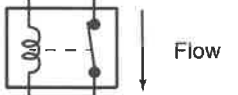
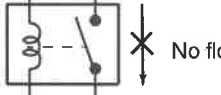
DESCRIPTION OF HARNESS	SYMBOL		DESCRIPTION OF HARNESS	SYMBOL	
FRONT HARNESS	(F)		DOOR NO.1 HARNESS	(DR1)	
FRONT NO.2 HARNESS	(F2)		DOOR NO.2 HARNESS	(DR2)	
ENGINE HARNESS	(E)		DOOR NO.3 HARNESS	(DR3)	
DASH HARNESS	(D)		DOOR NO.4 HARNESS	(DR4)	
REAR HARNESS	(R)		FLOOR HARNESS	(FR)	
REAR NO.2 HARNESS	(R2)		INTERIOR LIGHT HARNESS	(IN)	
REAR NO.3 HARNESS	(R3)		A/C HARNESS	(AC)	
INSTRUMENT PANEL HARNESS	(I)				
EMISSION HARNESS	(EM)				
EMISSION NO.2 HARNESS	(EM2)				
EMISSION NO.3 HARNESS	(EM3)				

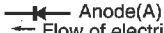
Symbols

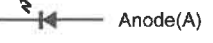
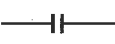
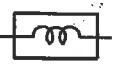
Symbol	Meaning	Symbol	Meaning	
<p>Battery</p> 	<ul style="list-style-type: none"> Generates electricity through chemical reaction. Supplies direct current to circuits. 	<p>Light</p> 	<ul style="list-style-type: none"> Emits light and generates heat when current flows through filament. 	
<p>Ground (1)</p> 	<ul style="list-style-type: none"> Connecting point to vehicle body or other ground wire where current flows from positive to negative terminal of battery. Ground (1) indicates a ground point to body through wire harness. Ground (2) indicates point where component is grounded directly to body. <p>Remarks</p> <ul style="list-style-type: none"> Current will not flow through a circuit if ground is faulty. 	<p>Resistance</p> 	<ul style="list-style-type: none"> A resistor with a constant value. Mainly used to protect electrical components in circuits by maintaining rated voltage. 	
<p>Ground (2)</p> 		<p>Fuse (1)</p>  <p>(box)</p>	<p>Motor</p> 	<ul style="list-style-type: none"> Converts electrical energy into mechanical energy.
<p>Fuse (2)</p>  <p>(Cartridge)</p>	<p>Precautions</p> <ul style="list-style-type: none"> Do not replace with fuses exceeding specified capacity. <p><Blade type> <Tube type></p>   <p><Cartridge type> <Fusible link></p>  	<p>Pump</p> 	<ul style="list-style-type: none"> Pulls in and discharges gases and liquids. 	
<p>Main fuse/ Fusible link</p> 		<p>Cigarette lighter</p> 	<p>Horn</p> 	<ul style="list-style-type: none"> Electrical coil that generates heat.
<p>Transistor (1)</p>  <p>NPN</p> 		<ul style="list-style-type: none"> Electrical switching component. Turns on when voltage is applied to the base (B). 	<p>Speaker</p> 	<ul style="list-style-type: none"> Generates sound when current flows.
<p>Transistor (2)</p>  <p>PNP</p>  <p>2 S C 828 A — Revision mark</p> <p>Semiconductor Number of terminals</p> <p>A: High-frequency PNP B: Low-frequency PNP C: High-frequency NPN D: Low-frequency NPN</p>	<ul style="list-style-type: none"> Reading code. 	<p>Heater</p> 	<ul style="list-style-type: none"> Generates heat when current flows. 	
		<p>Speed sensor</p> 	<ul style="list-style-type: none"> Movement of magnet in speedometer turns contact within sensor on and off. 	
		<p>Ignition switch</p> 	<ul style="list-style-type: none"> Turning ignition key switches circuit to operate various component. <p>(NOTE) Ignition switch is called engine switch on diesel vehicles.</p>	

Symbol	Meaning	Symbol	Meaning
<p>Switch (1)</p>  <p>Normally open (NO)</p>	<ul style="list-style-type: none"> Allows or breaks current flow by opening and closing circuits. 	<p>Harness Connection</p>  <p>When circuit C-D is connected to circuit A-B, the connection D is indicated by a black dot.</p>	 <p>For vehicles with ABS, use the A-B circuit.</p>
<p>Switch (2)</p>  <p>Normally closed (NC)</p>		<p>Selection</p>  <p>Diversion point D for the different circuits according to the vehicle's specification is indicated by a white dot.</p>	 <p>For vehicles without ABS, use the C-B circuit.</p>
<p>Relay (1)</p>  <p>Normally open (NO)</p>	<ul style="list-style-type: none"> Current flowing through coil produces electromagnetic force causing contact to open or close. <div style="display: flex; justify-content: space-around;"> <div style="text-align: center;"> <p>No current to coil</p>  </div> <div style="text-align: center;"> <p>Current to coil</p>  </div> </div>		
<p>Relay (2)</p>  <p>Normally closed (NC)</p>	<ul style="list-style-type: none"> Current flowing through coil produces electromagnetic force causing contact to close. <div style="display: flex; justify-content: space-around;"> <div style="text-align: center;"> <p>No current to coil</p>  </div> <div style="text-align: center;"> <p>Current to coil</p>  </div> </div>		
<p>Sensor (variable)</p> 	<ul style="list-style-type: none"> Resistance changes with other components operation. 	<p>Diode</p> 	<ul style="list-style-type: none"> Known as a semiconductor rectifier, the diode allows current flow in one direction only. <p>Cathode(K)  Anode(A)</p> <p>→ Flow of electric current</p> <p>K-□-A K-□-A K-□-A</p>
<p>Sensor (thermistor)</p> 	<ul style="list-style-type: none"> Resistance changes with temperature. 	<p>Light-emitting diode (LED)</p> 	<ul style="list-style-type: none"> A diode that lights when current flows. Unlike ordinary bulbs, the diode does not generate heat when lit. <p>Cathode(K)  Anode(A)</p> <p>Flow of current</p>
<p>Capacitor</p> 	<ul style="list-style-type: none"> Component that temporarily stores electrical charge. 		
<p>Solenoid</p> 	<ul style="list-style-type: none"> Current flowing through coil generates electromagnetic force to operate plungers. 	<p>Reference diode (Zener diode)</p> 	<ul style="list-style-type: none"> Allows current to flow in one direction up to a certain voltage; allows current to flow in the other direction once that voltage is exceeded.

Symbol	Meaning
<p>Extent of the change in the wiring position (1)</p>	<ul style="list-style-type: none"> The wiring position can be exchanged freely within the connector.
<p>Extent of the change in the wiring position (2)</p>	<ul style="list-style-type: none"> The wiring position can be exchanged according to the following combinations only. Between A and B, Between C and D, Between E and F
<p>Extent of the change in the wiring position (3)</p>	<ul style="list-style-type: none"> The wiring position can be exchanged according to the following combinations only. Between A, C and E, Between B, D and F

Abbreviations used in this booklet

3GR	Third Gear
4GR	Fourth Gear
A	Ampere
A/C	Air Conditioning
A/F	Air Fuel
A/R	Auto Reverse
AAS	Auto Adjusting Suspension
ABS	Anti-lock Braking System
ACC	Accessories
ACV	Air Control Valve
ADD	Additional
AIR	Secondary Air Injection
AIS	Air Injection System
ALL	Automatic Load Leveling
AM	Amplitude Modulation
AMP	Amplifier
ANT	Antenna
AP	Accelerator Pedal
AS	Autoshop
ASV	Air Supply Valve
AT	Automatic Transmission
ATX	Automatic Transaxle
B+	Battery Positive Voltage
BAC	Bypass Air Control
BARO	Barometric Pressure
CAC	Charge Air Cooler
CARB	Carburetor

CCT	Circuit
CIGAR	Cigarette
CIS	Continuous Fuel Injection System
CKP	Crankshaft Position Sensor
CLS	Closed Loop System
CMP	Camshaft Position Sensor
COMBI	Combination
CON	Conditioner
CONT	Control
CPU	Central Processing Unit
CSD	Cold Start Device
CTP	Closed Throttle Position
DEF	Defroster
DI	Distributor Ignition
DLC	Data Link Connector
DLI	Distributorless Ignition
DOHC	Double-Overhead Camshaft
DRL	Daytime Running light
DTC	Diagnostic Trouble Code(s)
DTM	Diagnostic Test Mode
ECPS	Electronically Controlled Power Steering
ECT	Engine Control Temperature
EGR	Exhaust Gas Recirculation
EI	Electronic Ignition
ELEC	Electric
ELR	Emergency Locking Retractor
ETR	Electronic Tuner

IF	Front
F/I	Fuel Injector
FC	Fan Control
FICB	Fast-Idle Cam Breaker
FM	Frequency Modulation
FP	Fuel Pump
FPR	Fuel Pump Relay
GEN	Generator
GND	Ground
H/D	Heater/Defroster
HEAT	Heater
HEI	High-Energy Ignition
HI	High
HO2S	Heated Oxygen Sensor
IAC	Idle Air Control
IAT	Intake Air Temperature
ICM	Ignition Control Module
IG	Ignition
ILLUMI	Illumination
INT	Intermittent
JB	Joint.Box
KS	Knock Sensor
LCD	Liquid Crystal Display
LF	Left Front
LH	Left Hand
LO	Low
LR	Left Rear
M	Motor
MAF	Mass Air Flow
MAP	Manifold Absolute Pressure
MFI	Multipoint Fuel Injection
MID	Middle
MIL	Malfunction Indicator Lamp
MIN	Minute
MIX	Mixture
MPX	Multiplex
MT	Manual Transmission
MTR	Mechanical Tuning Radio
MTX	Manual Transaxle
N	Neutral
NC	Normally Closed
NO	Normally Open
O2S	Oxygen Sensor
OBD	On-board Diagnostic
O/D	Over Drive
OFF	Switch Off
ON	Switch On

OSC	Oscillator
P	Power
P/S	Power Steering
PAIR	Pulsed Secondary Air Injection
PCM	Powertrain Control Module
PNP	Park/Neutral Position
PRCV	Pressure Regulator Control Solenoid Valve
PRG	Purge Solenoid Valve
PSP	Power Steering Pressure
PTC	Positive Temperature Coefficient Heater
QSS	Quick-Start System
R	Rear
REC	Recirculation
RF	Right Front
RH	Right Hand
RPM	Engine Speed
RR	Right Rear
SAS	Sophisticated Air Bag Sensor
SFI	Sequential Multipoint Fuel Injection
SOL	Solenoid
SPV	Spill Valve
ST	Start
SW	Switch
TC	Turbocharger
TCC	Torque Converter Clutch
TCM	Transmission(Transaxle)Control Module
TCS	Traction control system
TCV	Twin Scroll Turbocharger Solenoid Valve
TEMP	Temperature
TFT	Transaxle Fluid Temperature
TNS	Tail Number Side Lights
TICS	Triple Induction Control System
TP	Throttle Position Sensor
TR	Transmission Range
TR	Transmission(Transaxle)Range
TWS	Total Wiring System
V	Volt
VAF	Volume Air Flow Sensor
VENT	Ventilation
VOL	Volume
VR	Voltage Regulator
VRIS	Variable Resonance Induction System
VSS	Vehicle Speed Sensor
VTCS	Variable Tumble Control System
W	Watt(s)
WOT	Wide Open Throttle

GROUND POINT

<p>JC-01 JOINT CONNECTOR (F)</p>	<p>JC-02 JOINT CONNECTOR (F)</p>	<p>JC-03 JOINT CONNECTOR (F)</p>				
<p>6</p>	<p>7</p>					
<p>8</p>						

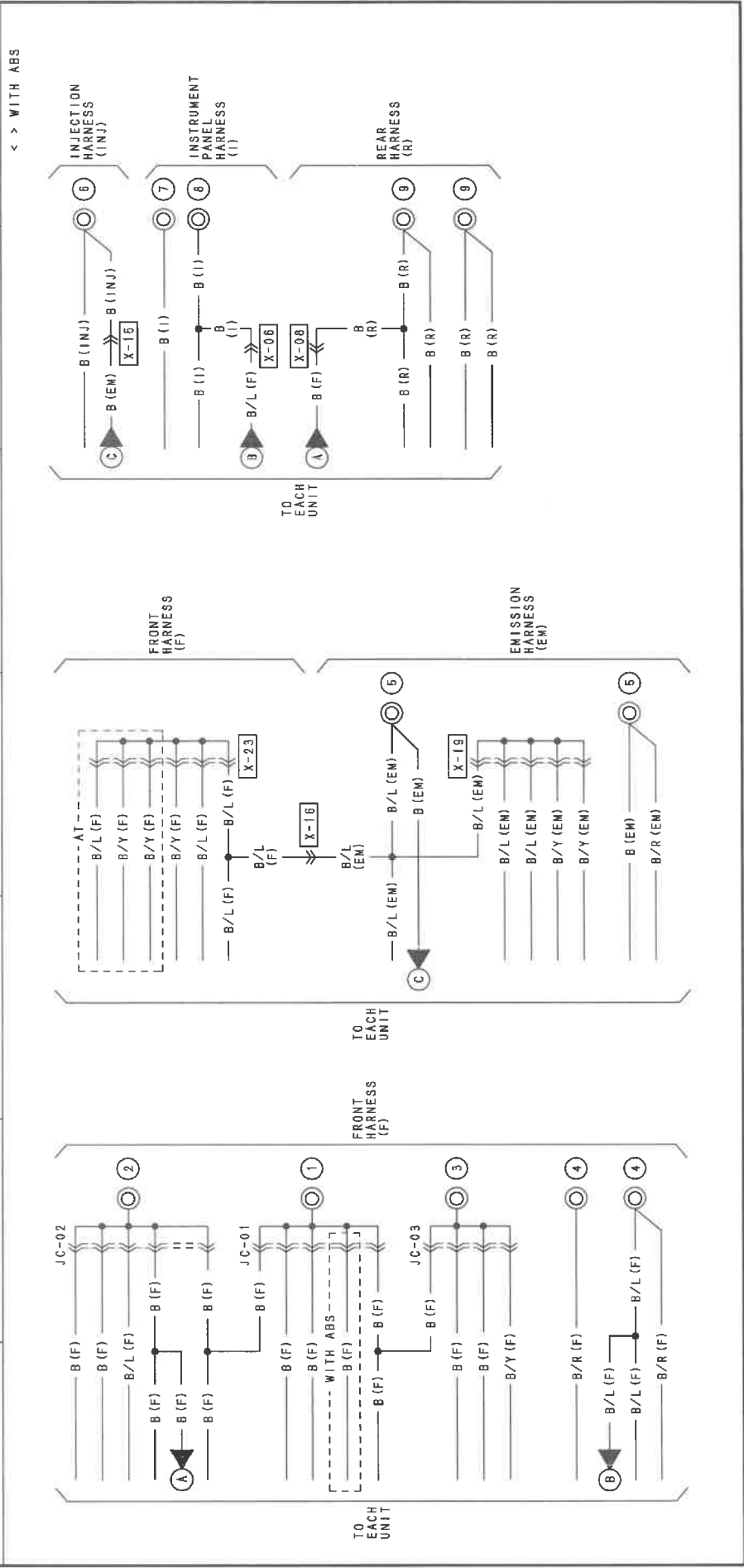

HARNES SYMBOL: [diagonal lines] (F) [diamond] (E) [zigzag] (R)

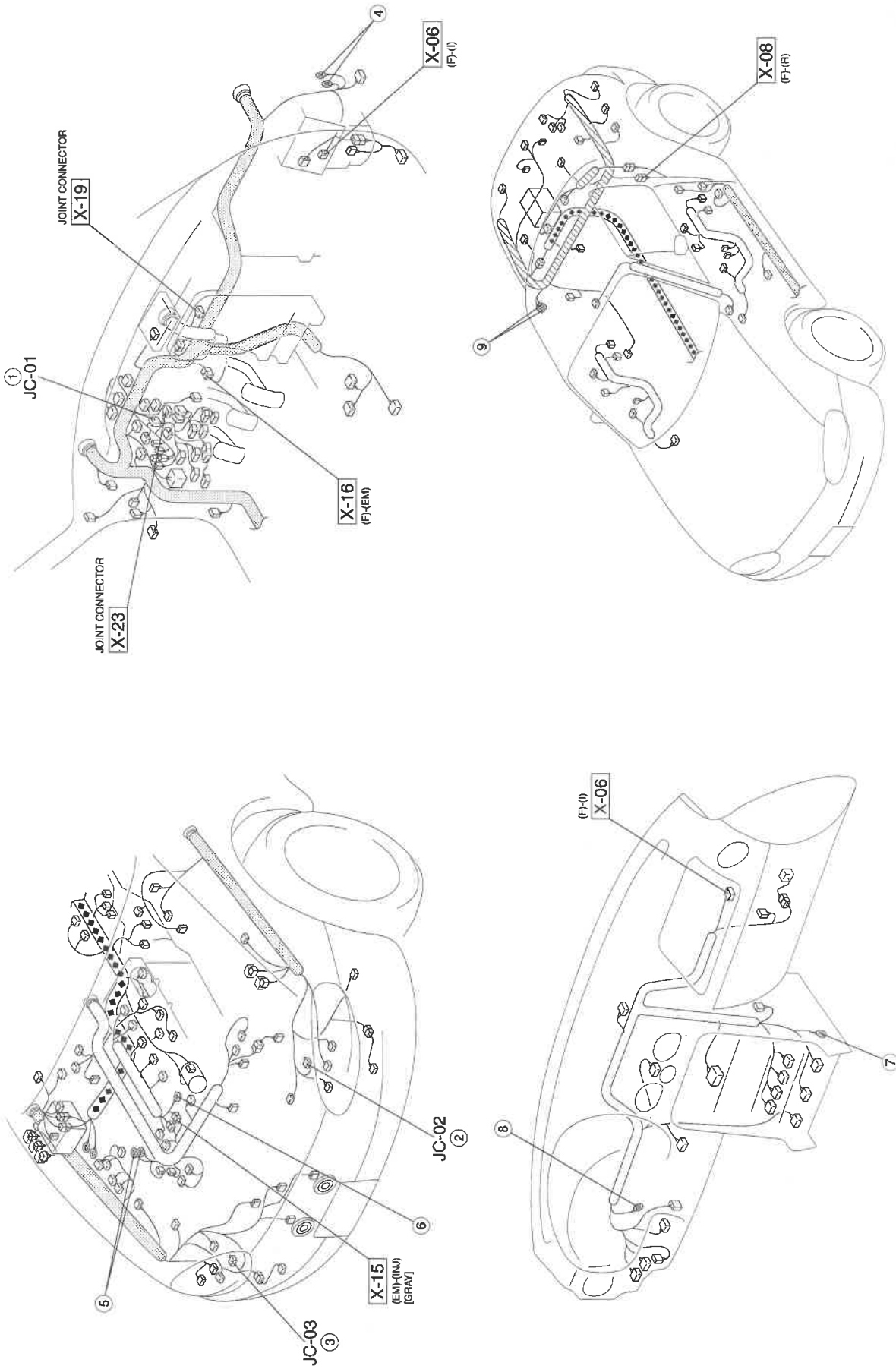

ELECTRICAL WIRING SCHEMATIC

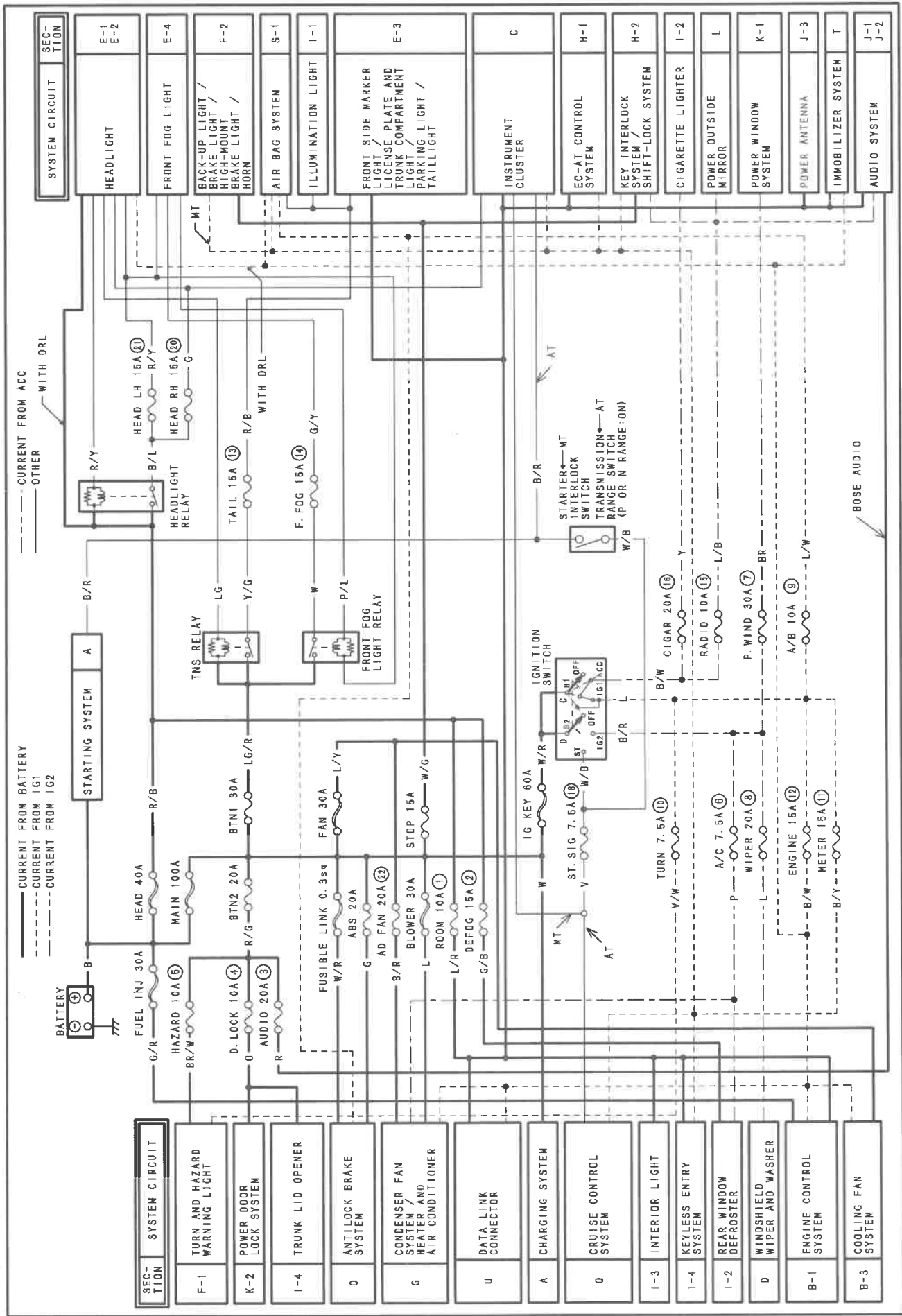

**THIS PAGE INTENTIONALLY
LEFT BLANK**

A

CHARGING SYSTEM / STARTING SYSTEM

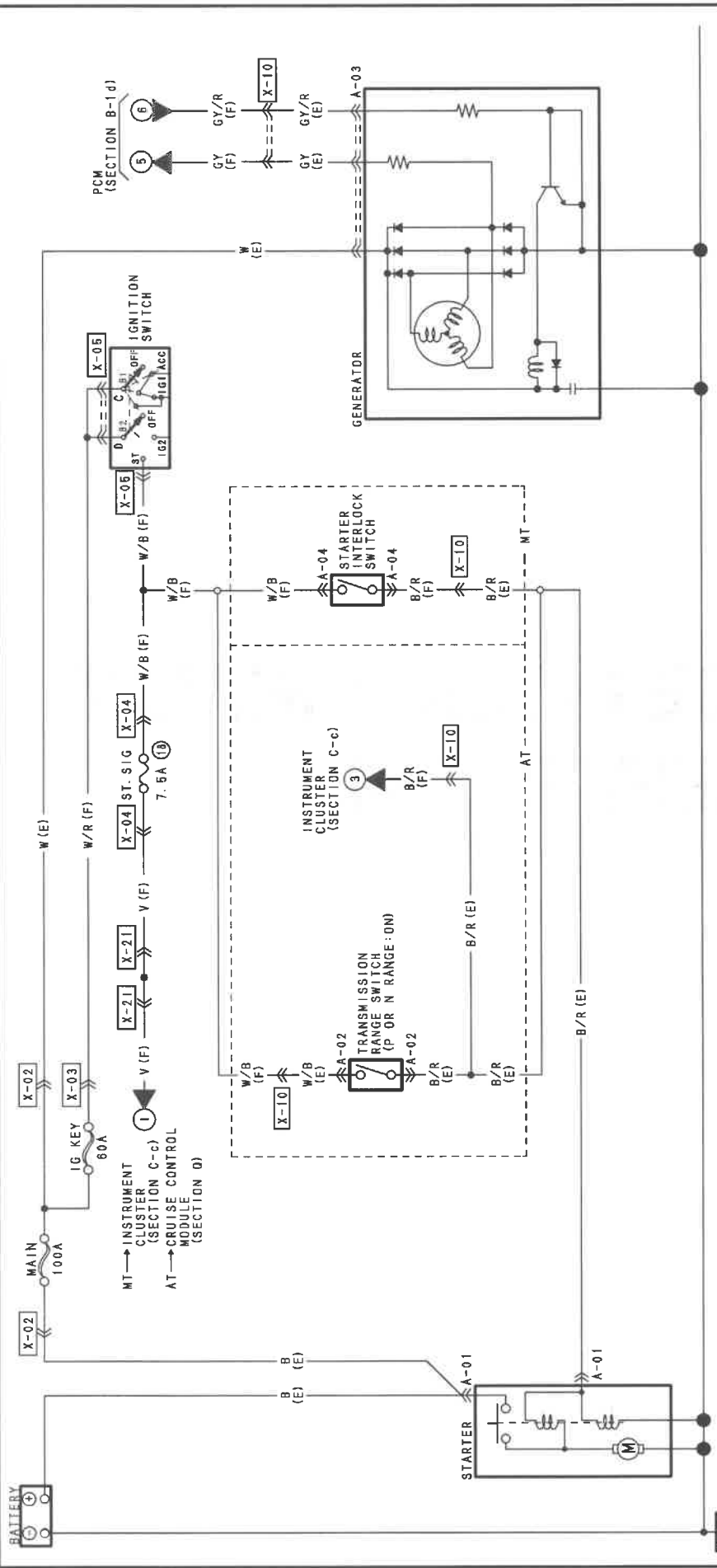

<p>A-01 STARTER (E)</p>	<p>A-02 TRANSMISSION RANGE SWITCH (E)</p>	<p>A-03 GENERATOR (E)</p>	<p>A-04 STARTER INTERLOCK SWITCH (F)</p>

HARNES SYMBOL : (F) (E) (R)

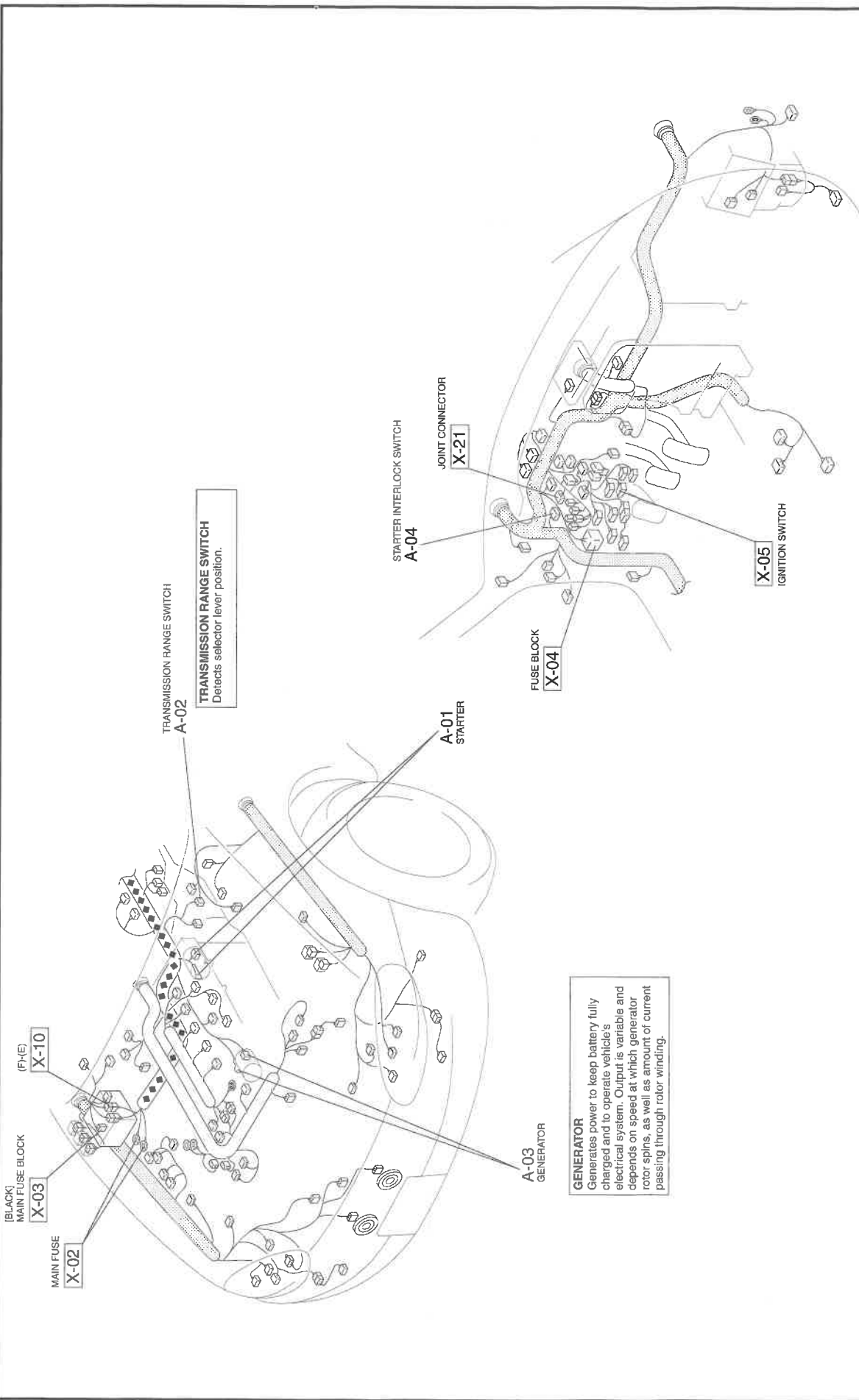

ENGINE CONTROL SYSTEM

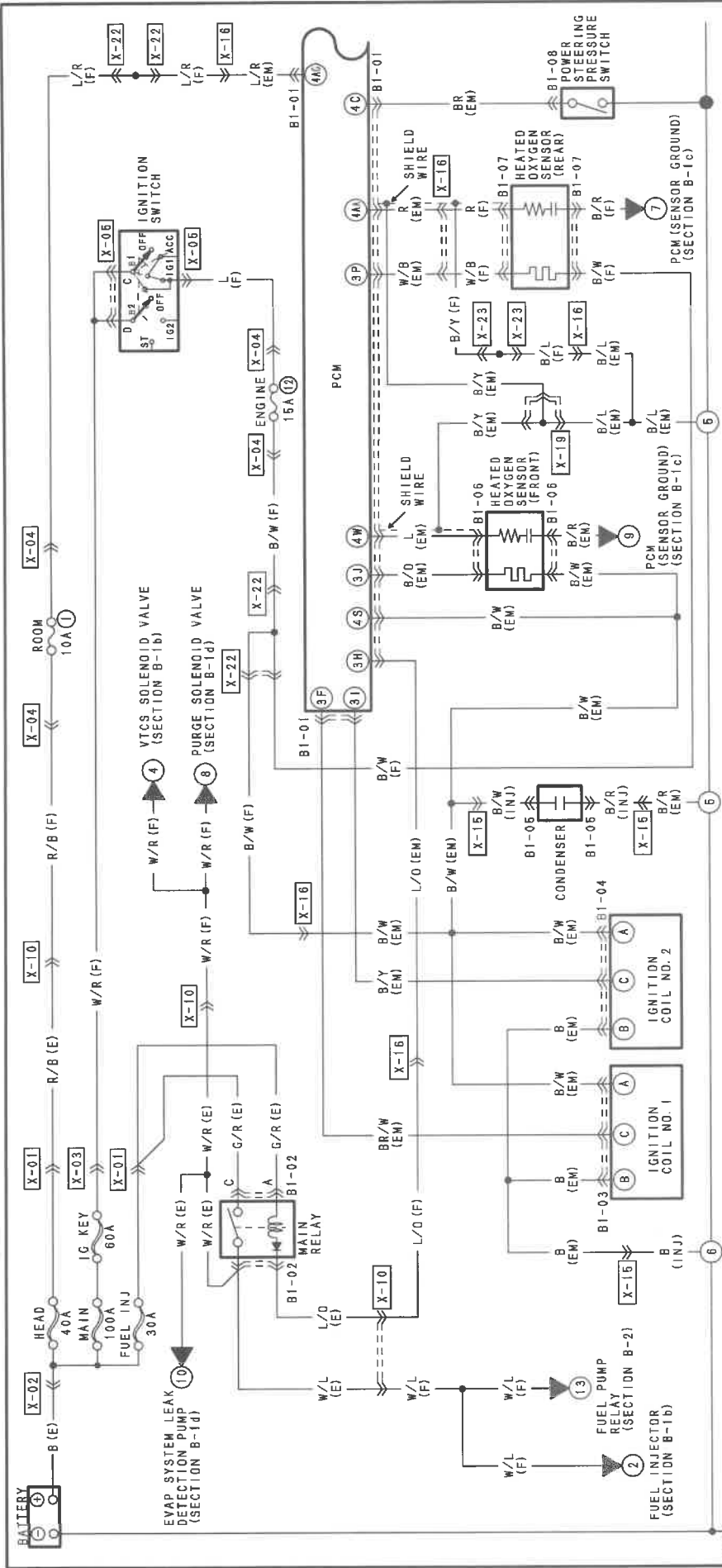

B1-01 PCM (EM)	B1-02 MAIN RELAY (E)	B1-03 IGNITION COIL NO. 1 (EM)	B1-04 IGNITION COIL NO. 2 (EM)	B1-05 CONDENSER (INJ)	B1-08 POWER STEERING PRESSURE SWITCH (EM)
<p>NOTE: THIS IS THE CONNECTOR AS SEEN FROM THE TERMINAL SIDE.</p>					

HARNES SYMBOL : (F) (E) (R)

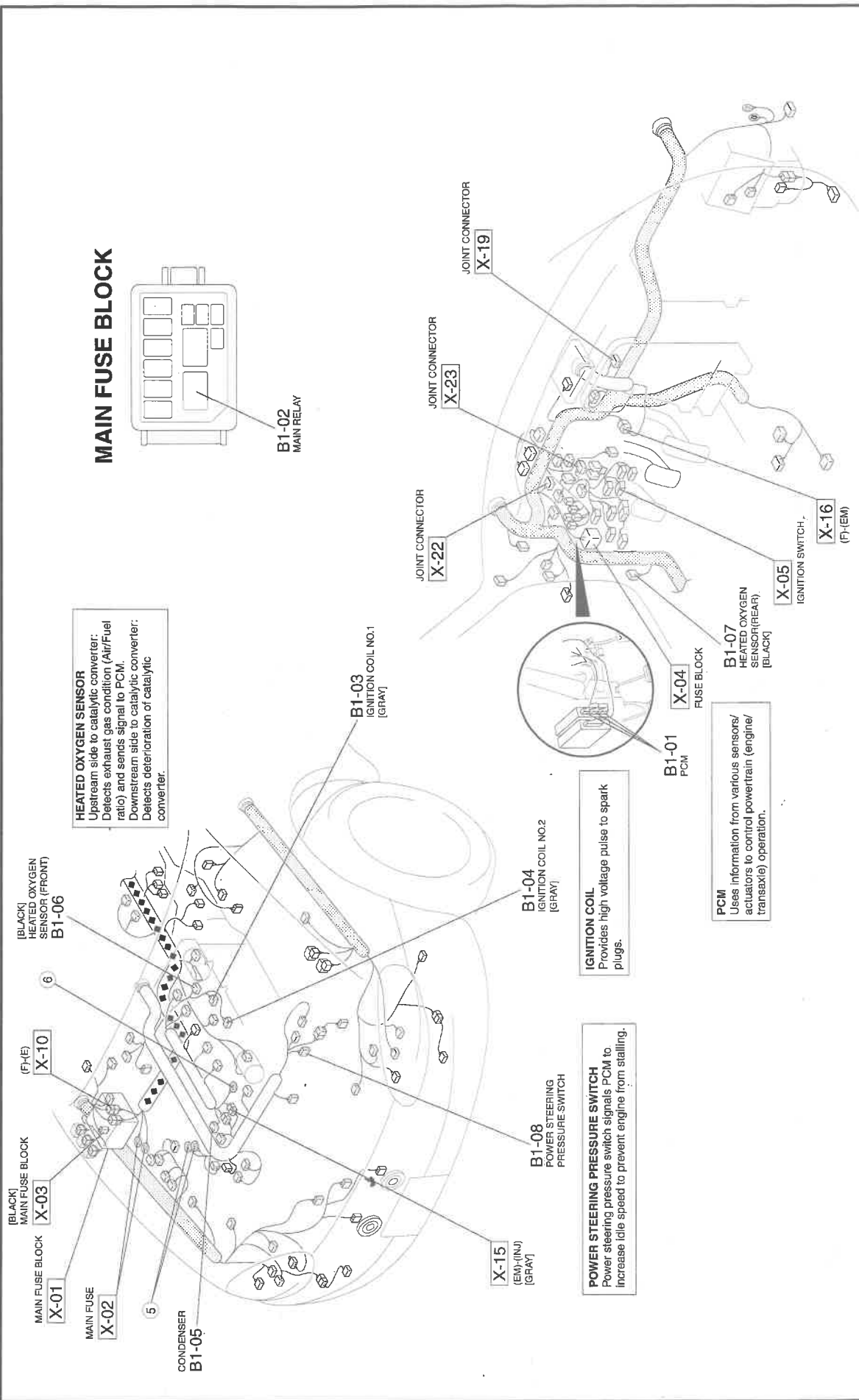

ENGINE CONTROL SYSTEM

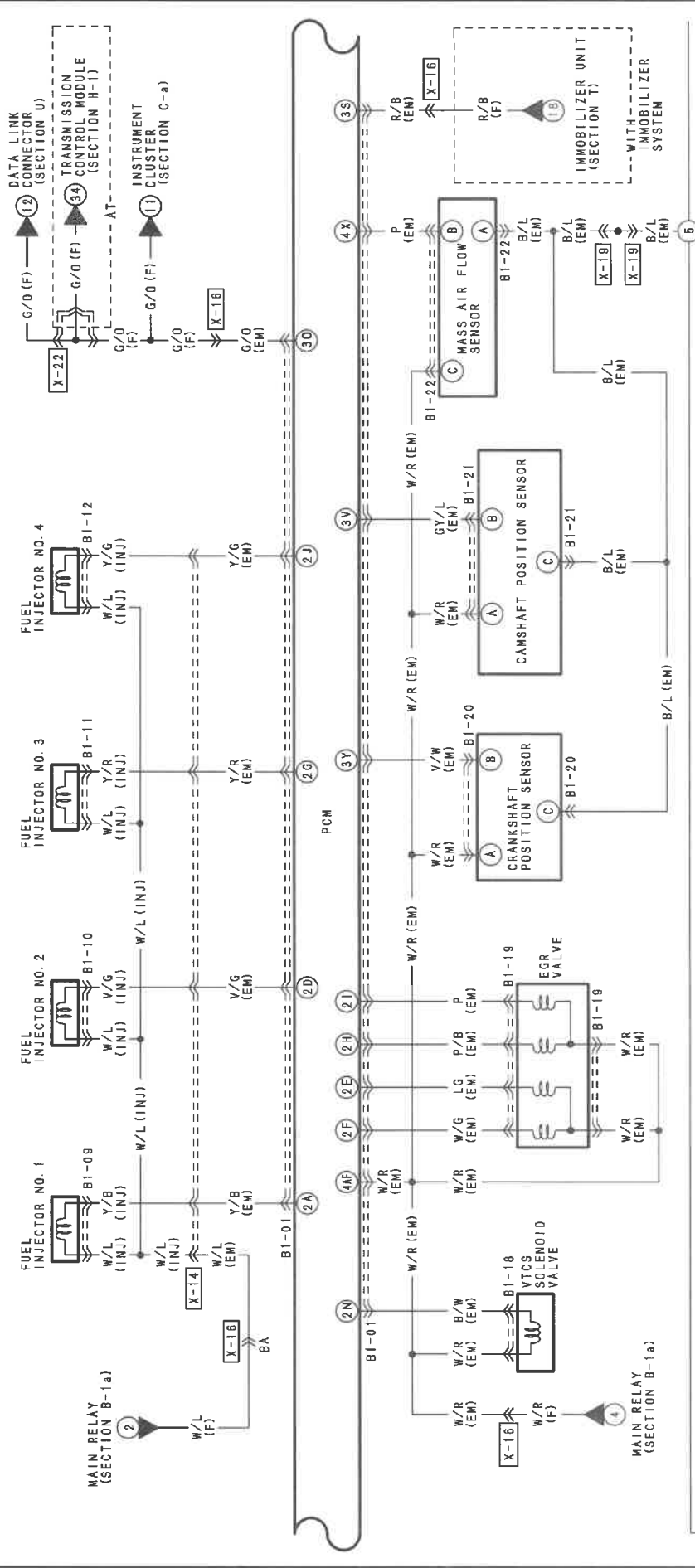

Component	Wiring Color	Terminal
BI-01 PCM (EM)	2P W/L	2N
	2Q R	2N
	2R W/L	2N
	2S O	2N
	2T V/R	2N
	2U W/L	2N
	2V R	2N
	2W O	2N
	2X V/R	2N
	2Y W/L	2N
	2Z R	2N
	2AA V/G	2N
	2AB R/L	2N
	2AC W/R	2N
	2AD L/R	2N
	2AE R/G	2N
	2AF W/L	2N
	2AG L/R	2N
	2AH R/G	2N
	2AI W/L	2N
	2AJ L/R	2N
	2AK R/G	2N
	2AL W/L	2N
	2AM L/R	2N
	2AN R/G	2N
	2AO W/L	2N
	2AP L/R	2N
	2AQ R/G	2N
	2AR W/L	2N
	2AS L/R	2N
	2AT R/G	2N
	2AU W/L	2N
	2AV L/R	2N
	2AW R/G	2N
	2AX W/L	2N
	2AY L/R	2N
	2AZ R/G	2N
	2BA W/L	2N
	2BB L/R	2N
	2BC R/G	2N
	2BD W/L	2N
	2BE L/R	2N
	2BF R/G	2N
	2BG W/L	2N
	2BH L/R	2N
	2BI R/G	2N
	2BJ W/L	2N
	2BK L/R	2N
	2BL R/G	2N
	2BM W/L	2N
	2BN L/R	2N
	2BO R/G	2N
	2BP W/L	2N
	2BQ L/R	2N
	2BR R/G	2N
	2BS W/L	2N
	2BT L/R	2N
	2BU R/G	2N
	2BV W/L	2N
	2BW L/R	2N
	2BX R/G	2N
	2BY W/L	2N
	2BZ L/R	2N
	2CA R/G	2N
	2CB W/L	2N
	2CC L/R	2N
	2CD R/G	2N
	2CE W/L	2N
	2CF L/R	2N
	2CG R/G	2N
	2CH W/L	2N
	2CI L/R	2N
	2CJ R/G	2N
	2CK W/L	2N
	2CL L/R	2N
	2CM R/G	2N
	2CN W/L	2N
	2CO L/R	2N
	2CP R/G	2N
	2CQ W/L	2N
	2CR L/R	2N
	2CS R/G	2N
	2CT W/L	2N
	2CU L/R	2N
	2CV R/G	2N
	2CW W/L	2N
	2CX L/R	2N
	2CY R/G	2N
	2CZ W/L	2N
	2CA L/R	2N
	2CB R/G	2N
	2CC W/L	2N
	2CD L/R	2N
	2CE R/G	2N
	2CF W/L	2N
	2CF L/R	2N
	2CG R/G	2N
	2CH W/L	2N
	2CI L/R	2N
	2CJ R/G	2N
	2CK W/L	2N
	2CL L/R	2N
	2CM R/G	2N
	2CN W/L	2N
	2CO L/R	2N
	2CP R/G	2N
	2CQ W/L	2N
	2CR L/R	2N
	2CS R/G	2N
	2CT W/L	2N
	2CU L/R	2N
	2CV R/G	2N
	2CW W/L	2N
	2CX L/R	2N
	2CY R/G	2N
	2CZ W/L	2N
	2CA L/R	2N
	2CB R/G	2N
	2CC W/L	2N
	2CD L/R	2N
	2CE R/G	2N
	2CF W/L	2N
	2CF L/R	2N
	2CG R/G	2N
	2CH W/L	2N
	2CI L/R	2N
	2CJ R/G	2N
	2CK W/L	2N
	2CL L/R	2N
	2CM R/G	2N
	2CN W/L	2N
	2CO L/R	2N
	2CP R/G	2N
	2CQ W/L	2N
	2CR L/R	2N
	2CS R/G	2N
	2CT W/L	2N
	2CU L/R	2N
	2CV R/G	2N
	2CW W/L	2N
	2CX L/R	2N
	2CY R/G	2N
	2CZ W/L	2N
	2CA L/R	2N
	2CB R/G	2N
	2CC W/L	2N
	2CD L/R	2N
	2CE R/G	2N
	2CF W/L	2N
	2CF L/R	2N
	2CG R/G	2N
	2CH W/L	2N
	2CI L/R	2N
	2CJ R/G	2N
	2CK W/L	2N
	2CL L/R	2N
	2CM R/G	2N
	2CN W/L	2N
	2CO L/R	2N
	2CP R/G	2N
	2CQ W/L	2N
	2CR L/R	2N
	2CS R/G	2N
	2CT W/L	2N
	2CU L/R	2N
	2CV R/G	2N
	2CW W/L	2N
	2CX L/R	2N
	2CY R/G	2N
	2CZ W/L	2N
	2CA L/R	2N
	2CB R/G	2N
	2CC W/L	2N
	2CD L/R	2N
	2CE R/G	2N
	2CF W/L	2N
	2CF L/R	2N
	2CG R/G	2N
	2CH W/L	2N
	2CI L/R	2N
	2CJ R/G	2N
	2CK W/L	2N
	2CL L/R	2N
	2CM R/G	2N
	2CN W/L	2N
	2CO L/R	2N
	2CP R/G	2N
	2CQ W/L	2N
	2CR L/R	2N
	2CS R/G	2N
	2CT W/L	2N
	2CU L/R	2N
	2CV R/G	2N
	2CW W/L	2N
	2CX L/R	2N
	2CY R/G	2N
	2CZ W/L	2N
	2CA L/R	2N
	2CB R/G	2N
	2CC W/L	2N
	2CD L/R	2N
	2CE R/G	2N
	2CF W/L	2N
	2CF L/R	2N
	2CG R/G	2N
	2CH W/L	2N
	2CI L/R	2N
	2CJ R/G	2N
	2CK W/L	2N
	2CL L/R	2N
	2CM R/G	2N
	2CN W/L	2N
	2CO L/R	2N
	2CP R/G	2N
	2CQ W/L	2N
	2CR L/R	2N
	2CS R/G	2N
	2CT W/L	2N
	2CU L/R	2N
	2CV R/G	2N
	2CW W/L	2N
	2CX L/R	2N
	2CY R/G	2N
	2CZ W/L	2N
	2CA L/R	2N
	2CB R/G	2N
	2CC W/L	2N
	2CD L/R	2N
	2CE R/G	2N
	2CF W/L	2N
	2CF L/R	2N
	2CG R/G	2N
	2CH W/L	2N
	2CI L/R	2N
	2CJ R/G	2N
	2CK W/L	2N
	2CL L/R	2N
	2CM R/G	2N
	2CN W/L	2N
	2CO L/R	2N
	2CP R/G	2N
	2CQ W/L	2N
	2CR L/R	2N
	2CS R/G	2N
	2CT W/L	2N
	2CU L/R	2N
	2CV R/G	2N
	2CW W/L	2N
	2CX L/R	2N
	2CY R/G	2N
	2CZ W/L	2N
	2CA L/R	2N
	2CB R/G	2N
	2CC W/L	2N
	2CD L/R	2N
	2CE R/G	2N
	2CF W/L	2N
	2CF L/R	2N
	2CG R/G	2N
	2CH W/L	2N
	2CI L/R	2N
	2CJ R/G	2N
	2CK W/L	2N
	2CL L/R	2N
	2CM R/G	2N
	2CN W/L	2N
	2CO L/R	2N
	2CP R/G	2N
	2CQ W/L	2N
	2CR L/R	2N
	2CS R/G	2N
	2CT W/L	2N
	2CU L/R	2N
	2CV R/G	2N
	2CW W/L	2N
	2CX L/R	2N
	2CY R/G	2N
	2CZ W/L	2N
	2CA L/R	2N
	2CB R/G	2N
	2CC W/L	2N
	2CD L/R	2N
	2CE R/G	2N
	2CF W/L	2N
	2CF L/R	2N
	2CG R/G	2N
	2CH W/L	2N
	2CI L/R	2N
	2CJ R/G	2N
	2CK W/L	2N
	2CL L/R	2N
	2CM R/G	2N
	2CN W/L	2N
	2CO L/R	2N
	2CP R/G	2N
	2CQ W/L	2N
	2CR L/R	2N
	2CS R/G	2N
	2CT W/L	2N
	2CU L/R	2N
	2CV R/G	2N
	2CW W/L	2N
	2CX L/R	2N
	2CY R/G	2N
	2CZ W/L	2N
	2CA L/R	2N
	2CB R/G	2N
	2CC W/L	2N
	2CD L/R	2N
	2CE R/G	2N
	2CF W/L	2N
	2CF L/R	2N
	2CG R/G	2N
	2CH W/L	2N
	2CI L/R	2N
	2CJ R/G	2N
	2CK W/L	2N
	2CL L/R	2N
	2CM R/G	2N
	2CN W/L	2N
	2CO L/R	2N
	2CP R/G	2N
	2CQ W/L	2N
	2CR L/R	2N
	2CS R/G	2N
	2CT W/L	2N
	2CU L/R	2N
	2CV R/G	2N
	2CW W/L	2N
	2CX L/R	2N
	2CY R/G	2N
	2CZ W/L	2N
	2CA L/R	2N
	2CB R/G	2N
	2CC W/L	2N
	2CD L/R	2N
	2CE R/G	2N
	2CF W/L	2N
	2CF L/R	2N
	2CG R/G	2N
	2CH W/L	2N
	2CI L/R	2N
	2CJ R/G	2N
	2CK W/L	2N
	2CL L/R	2N
	2CM R/G	2N
	2CN W/L	2N
	2CO L/R	2N
	2CP R/G	2N
	2CQ W/L	2N
	2CR L/R	2N
	2CS R/G	2N
	2CT W/L	2N
	2CU L/R	2N
	2CV R/G	2N
	2CW W/L	2N
	2CX L/R	2N
	2CY R/G	2N
	2CZ W/L	2N
	2CA L/R	2N
	2CB R/G	2N
	2CC W/L	2N
	2CD L/R	2N
	2CE R/G	2N
	2CF W/L	2N
	2CF L/R	2N
	2CG R/G	2N
	2CH W/L	2N
	2CI L/R	2N
	2CJ R/G	2N
	2CK W/L	2N
	2CL L/R	2N
	2CM R/G	2N
	2CN W/L	2N
	2CO L/R	2N
	2CP R/G	2N
	2CQ W/L	2N
	2CR L/R	2N
	2CS R/G	2N
	2CT W/L	2N
	2CU L/R	2N
	2CV R/G	2N
	2CW W/L	2N
	2CX L/R	2N
	2CY R/G	2N
	2CZ W/L	2N
	2CA L/R	2N
	2CB R/G	2N
	2CC W/L	2N
	2CD L/R	2N

HARNES SYMBOL : [Dotted] (F) [Diagonal Lines] (E) [Cross-hatch] (R)

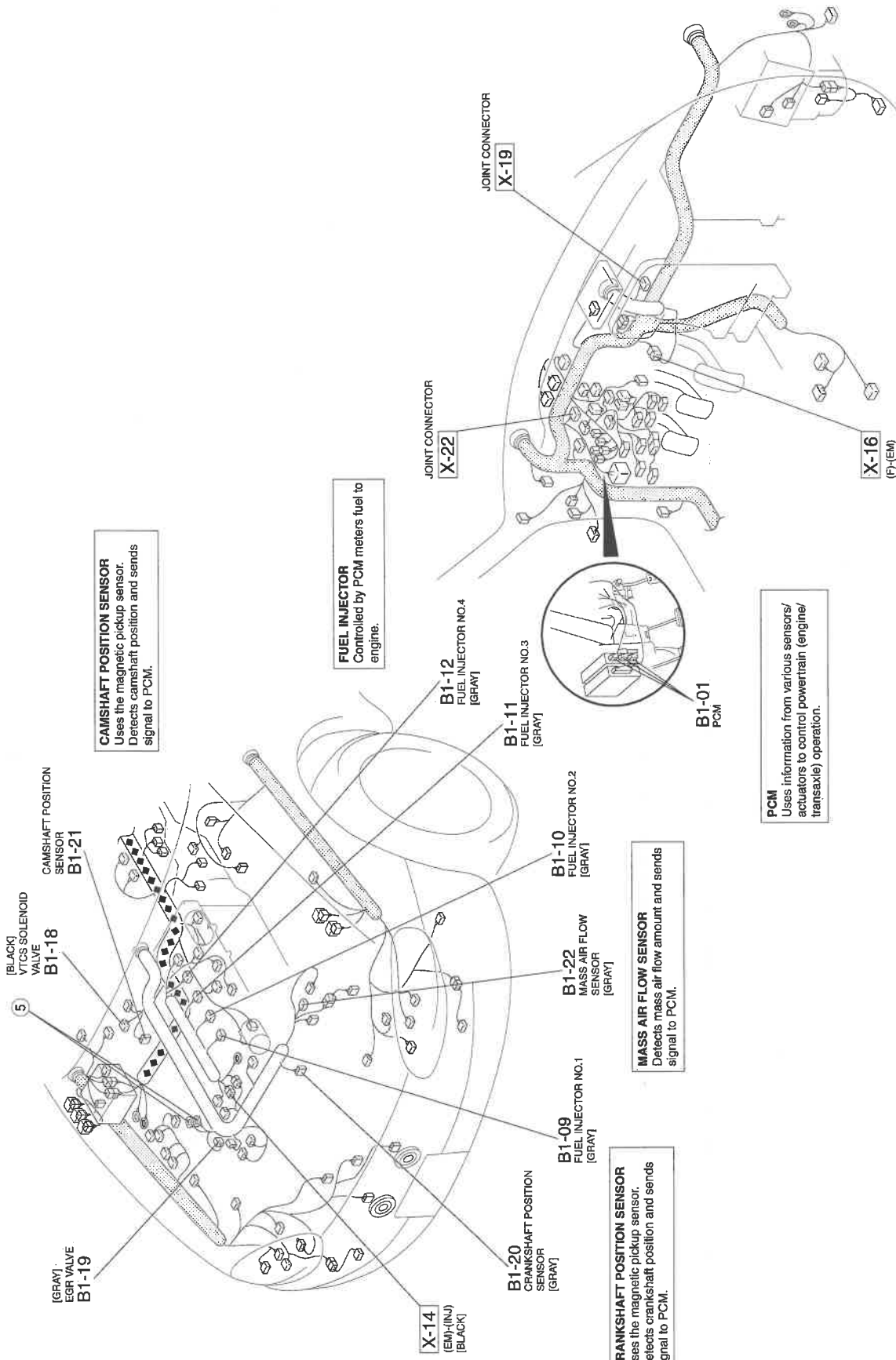

ENGINE CONTROL SYSTEM

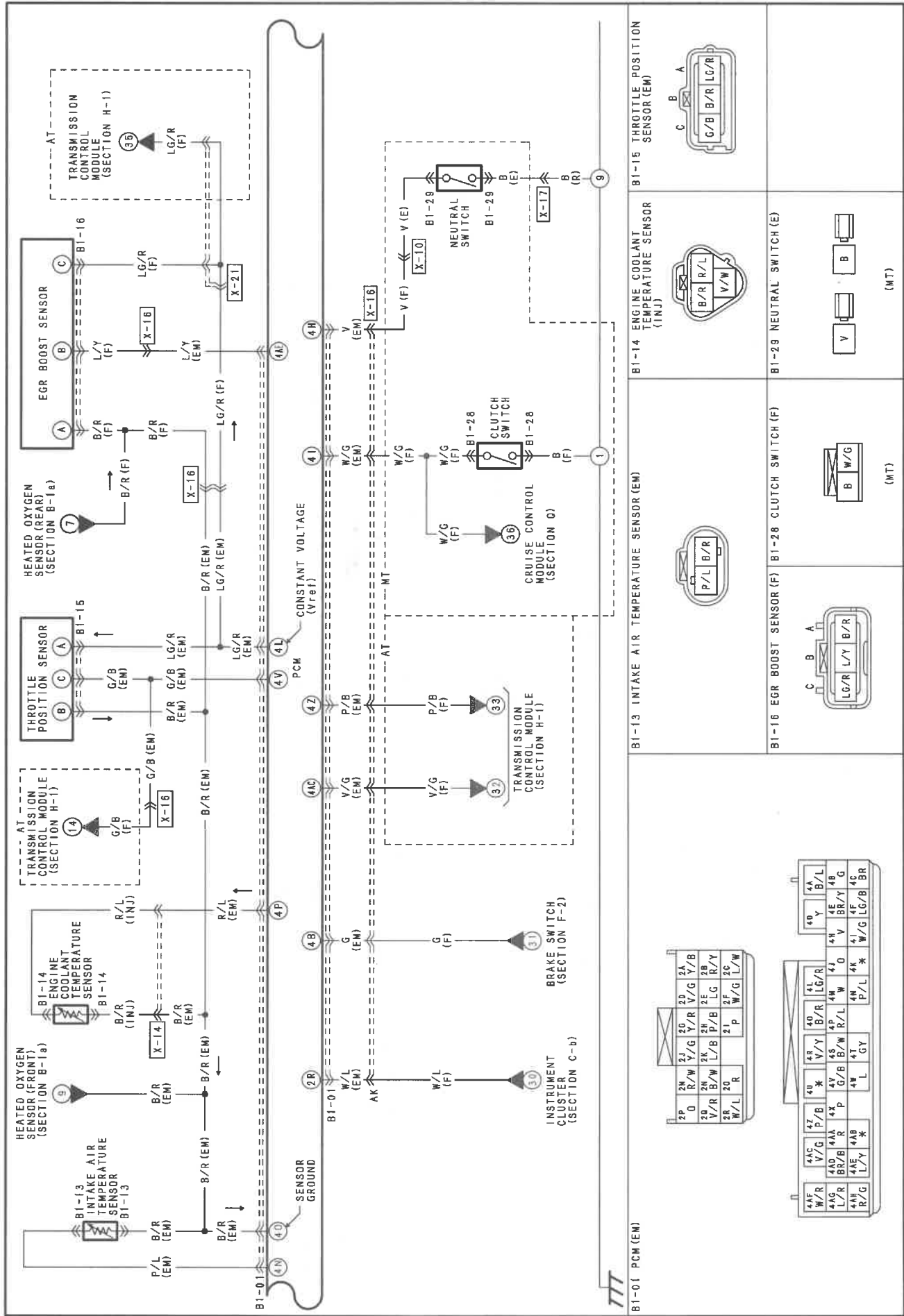

HARNES SYMBOL: (F) (E) (R)

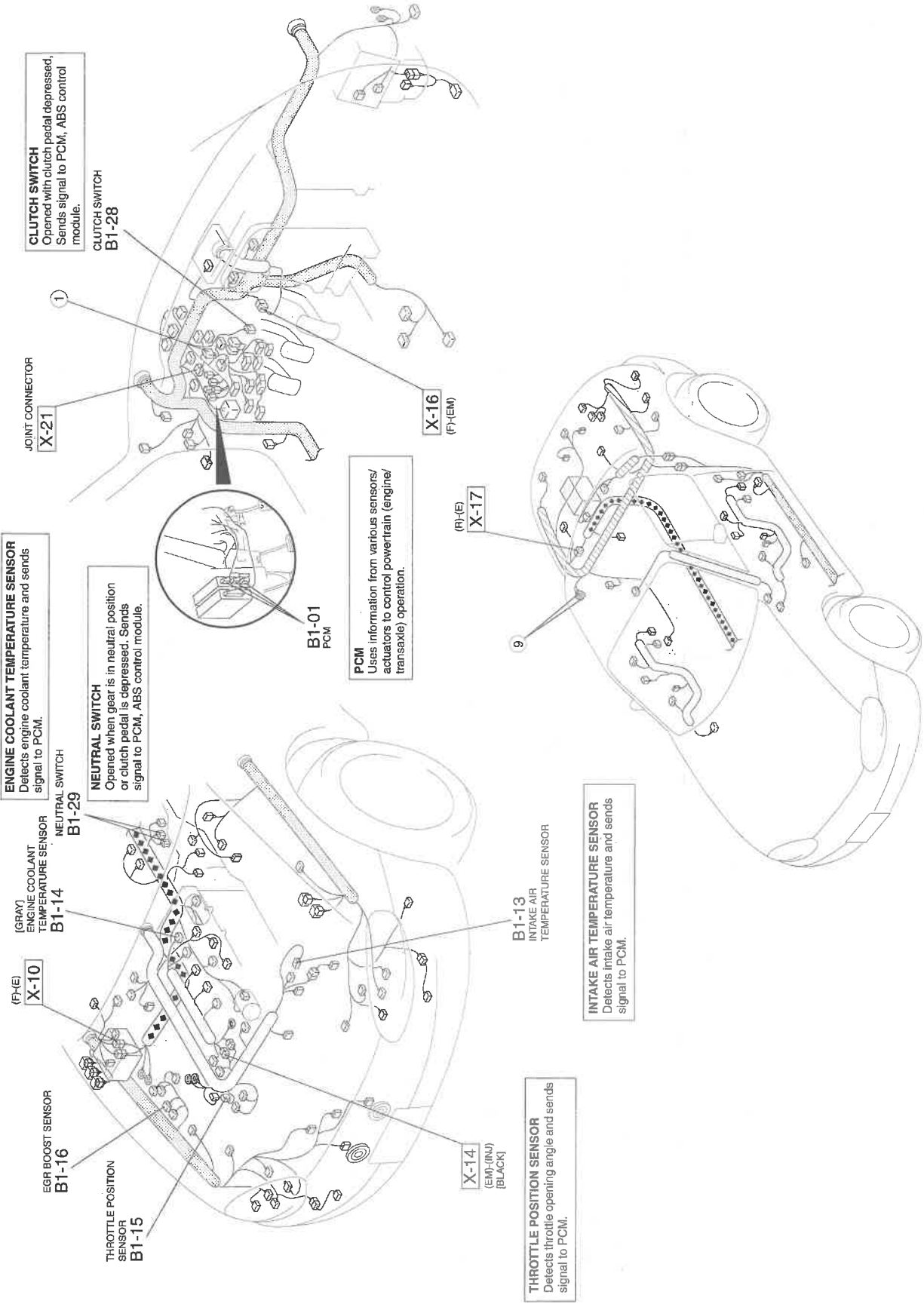

ENGINE CONTROL SYSTEM

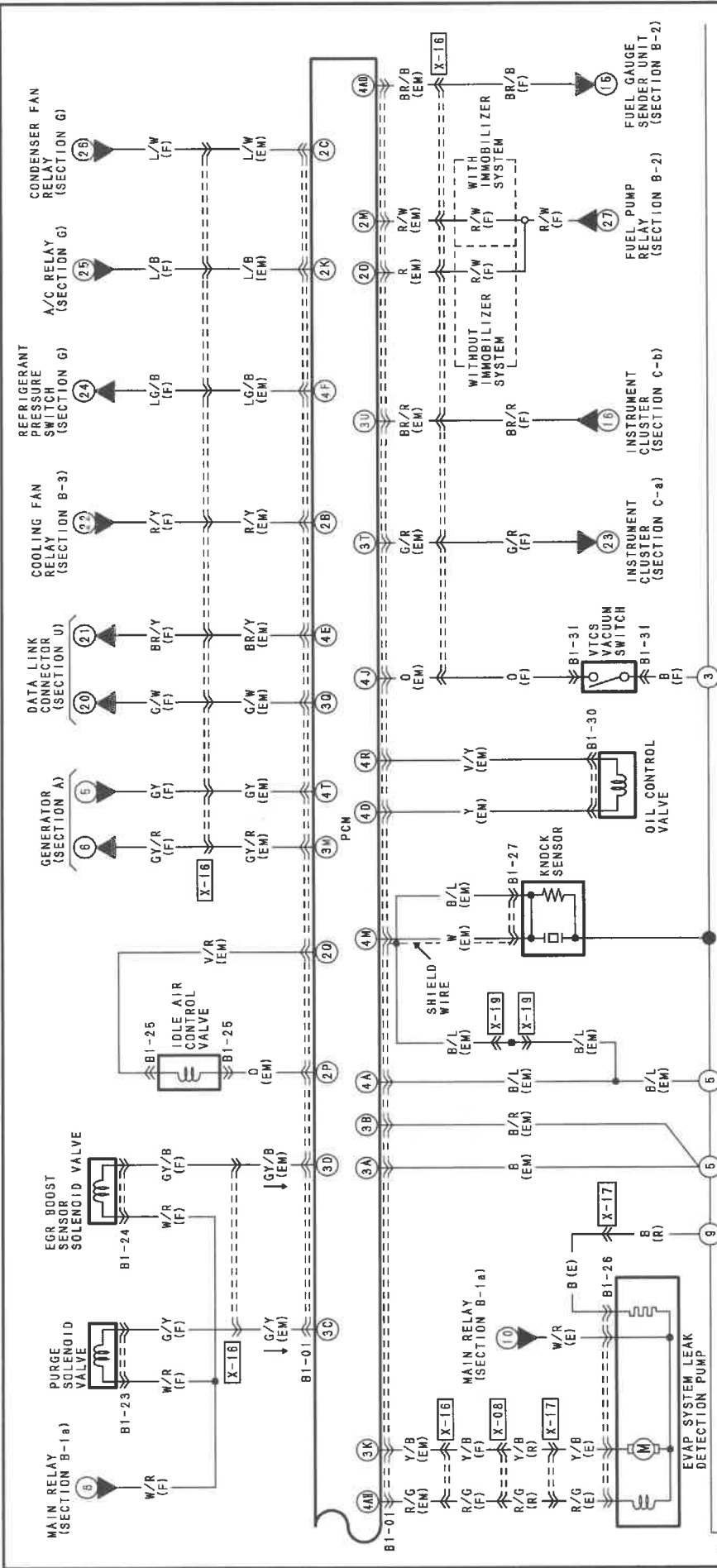

B1-23 PURGE SOLENOID VALVE (F)	B1-24 EGR BOOST SENSOR SOLENOID VALVE (F)	B1-25 IDLE AIR CONTROL VALVE (EM)	B1-26 EVAP SYSTEM LEAK DETECTION PUMP (E)
B1-27 KNOCK SENSOR (EM)	B1-30 OIL CONTROL VALVE (EM)	B1-31 VTCS VACUUM SWITCH (F)	

HARNES SYMBOL : (F) (E) (R)

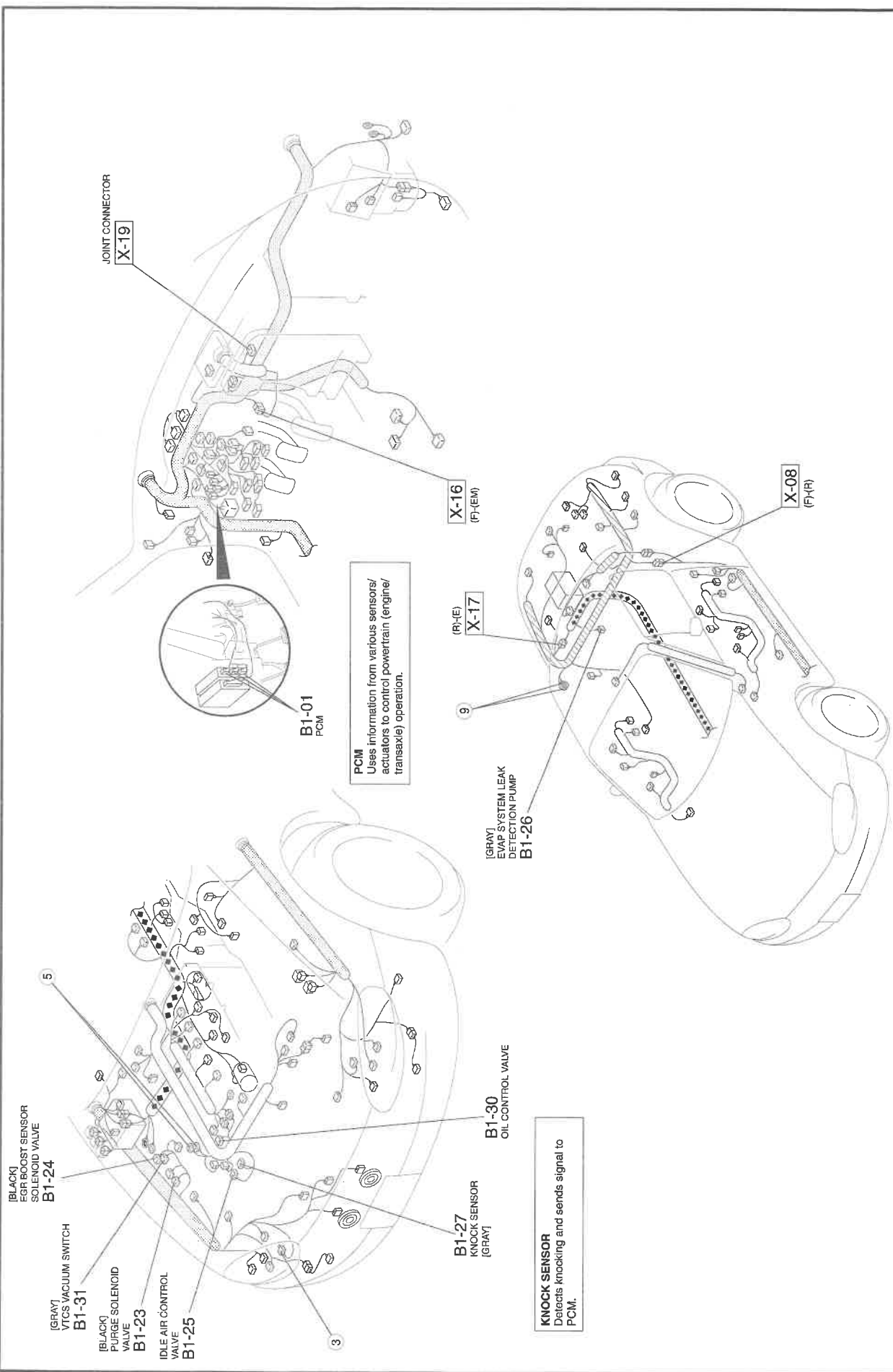

(BLACK)
EGR BOOST SENSOR
SOLENOID VALVE
B1-24

(GRAY)
VTCS VACUUM SWITCH
B1-31

(BLACK)
PURGE SOLENOID
VALVE
B1-23

IDLE AIR CONTROL
VALVE
B1-25

B1-27
KNOCK SENSOR
(GRAY)

B1-30
OIL CONTROL VALVE

KNOCK SENSOR
Detects knocking and sends signal to PCM.

B1-01
PCM

PCM
Uses information from various sensors/
actuators to control powertrain (engine/
transaxle) operation.

X-16
(F)(EM)

(R)(E)
X-17

(GRAY)
EVAP SYSTEM LEAK
DETECTION PUMP
B1-26

X-08
(F)(R)

JOINT CONNECTOR
X-19

FUEL CONTROL SYSTEM

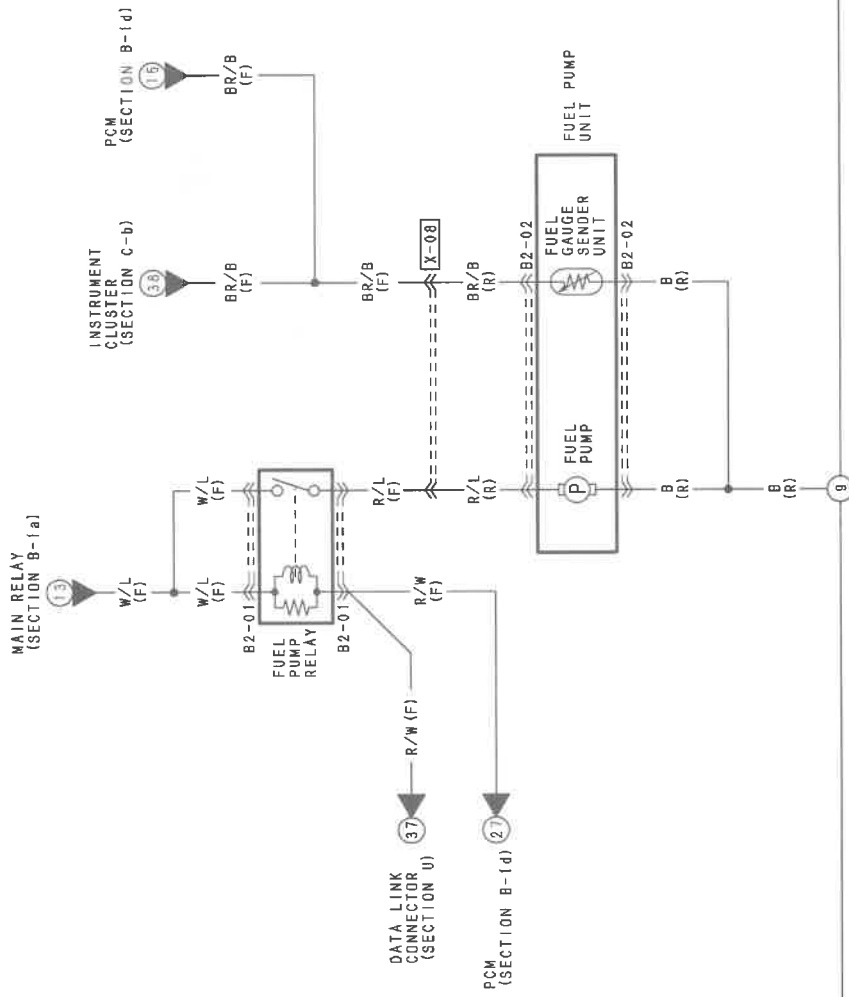

B2-01 FUEL PUMP RELAY (F)

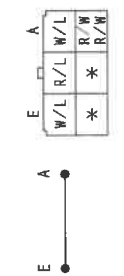

B2-02 FUEL PUMP UNIT (R)

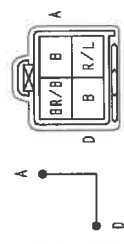

HARNESS SYMBOL :  (F)  (E)  (R)

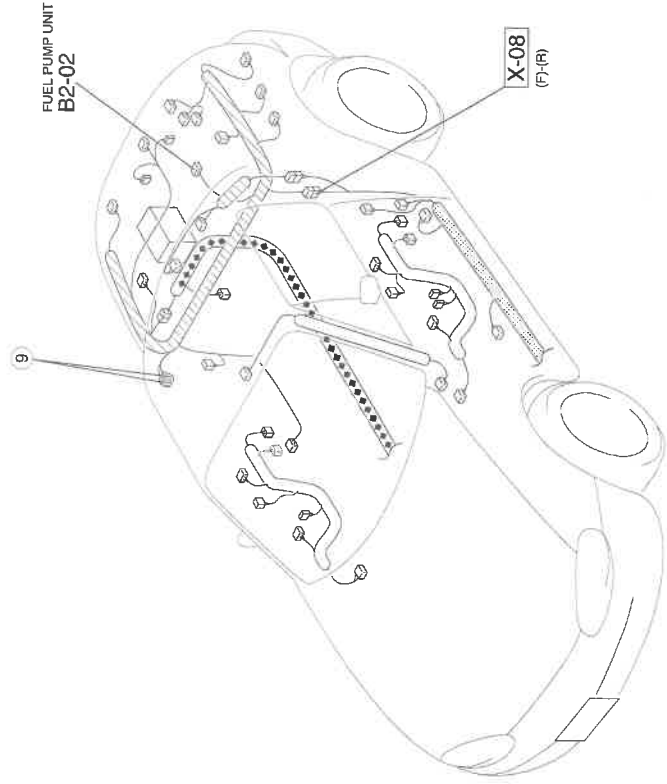
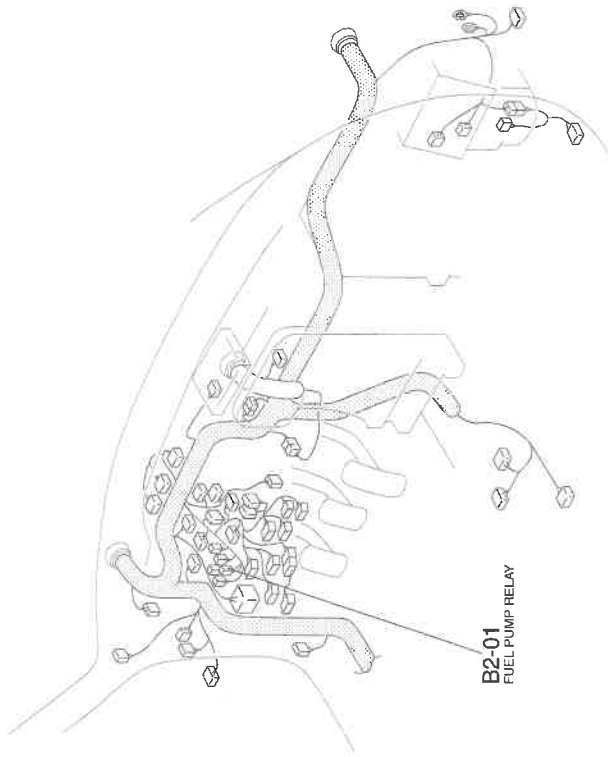

COOLING FAN SYSTEM

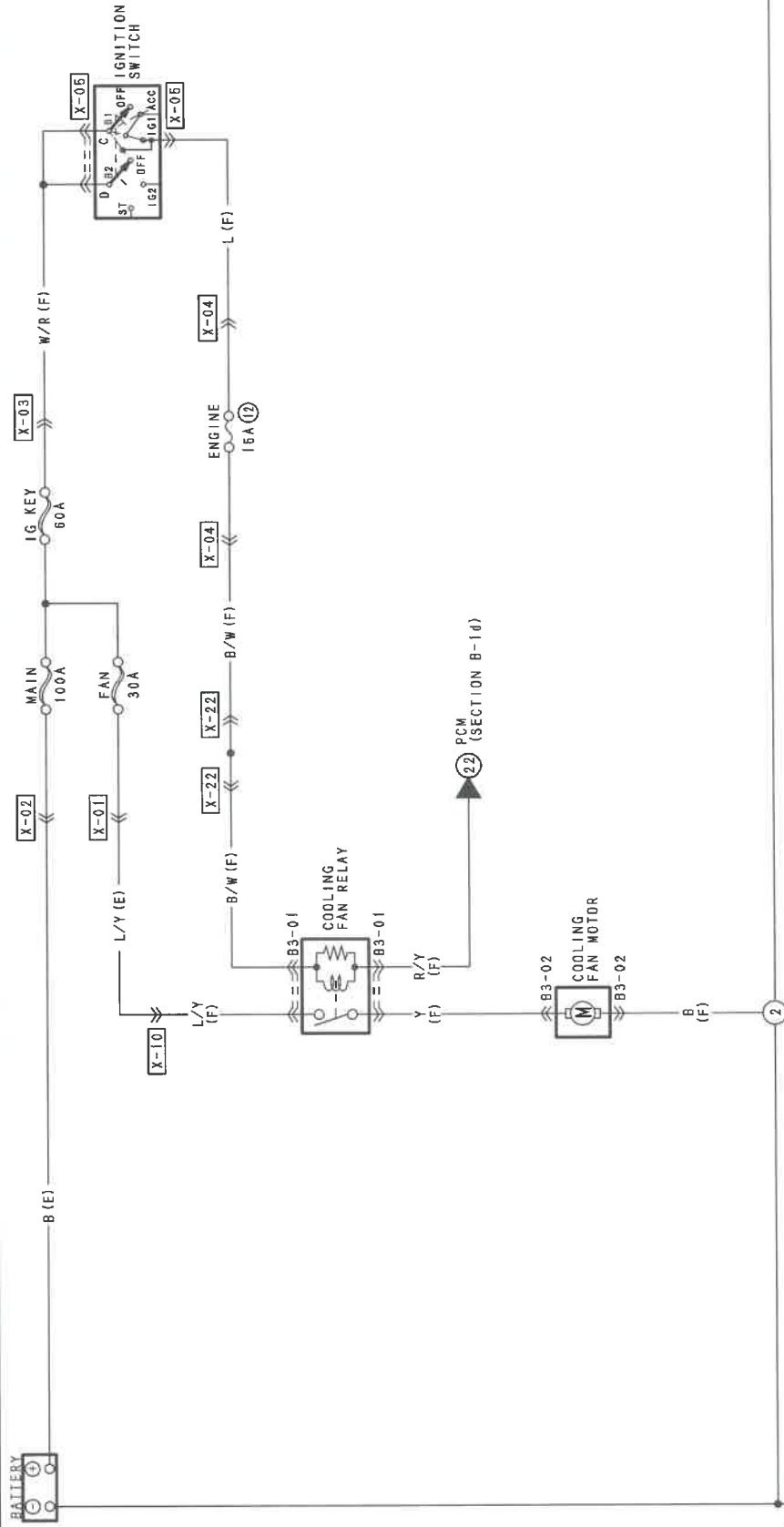

B3-01 COOLING FAN RELAY (F)

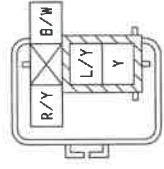

B3-02 COOLING FAN MOTOR (F)



HARNES SYMBOL : (F) (E) (R)

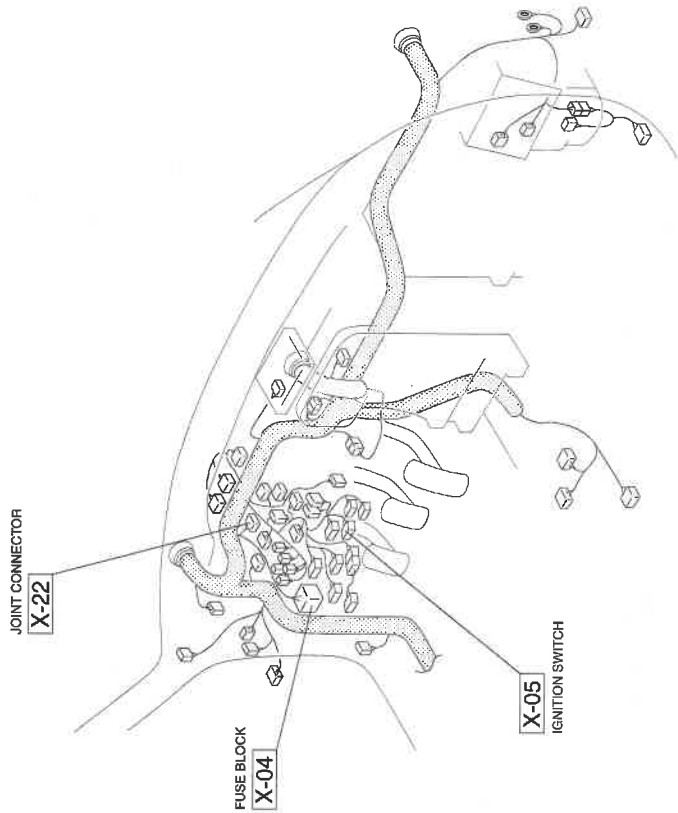
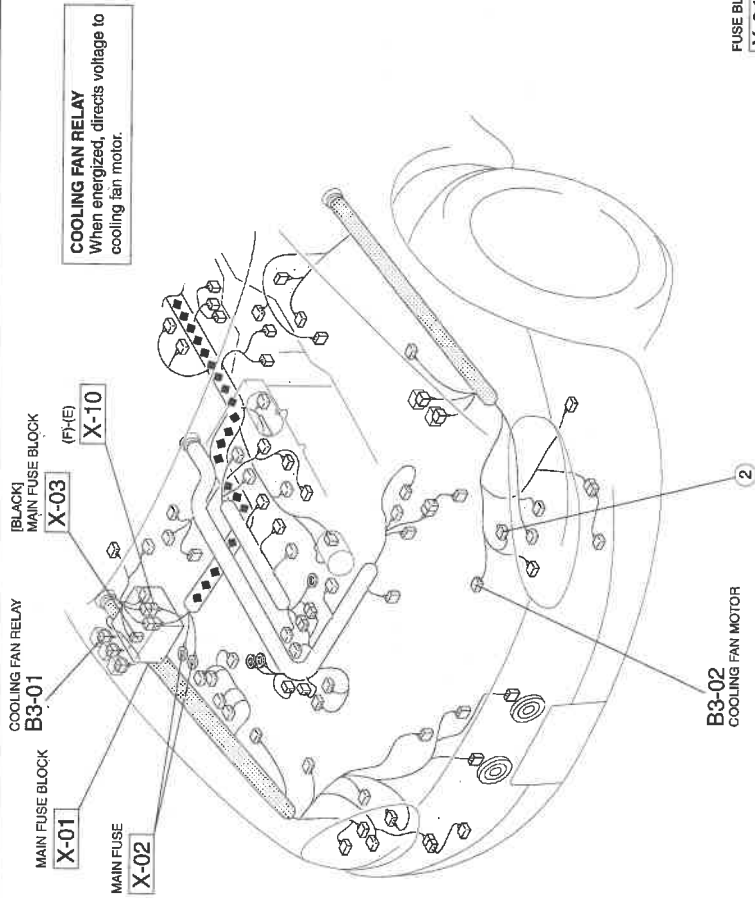

INSTRUMENT CLUSTER

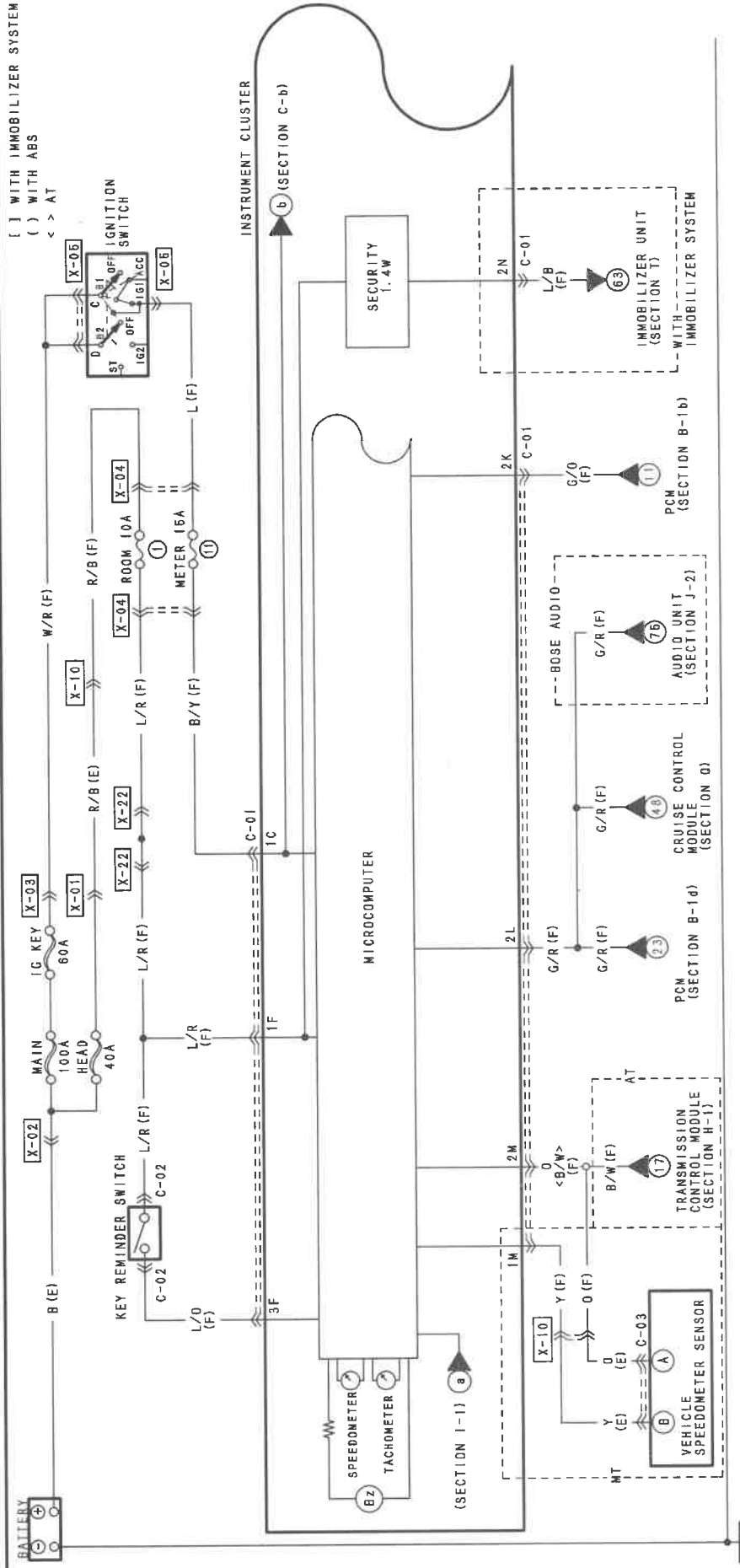

C-01 INSTRUMENT CLUSTER (F)

V	*	B/L	Y	W/R	*	G	W	I	H	I	J	K	L	M	L/R	*	L/R	*	B/Y	BR/Y	BR/B
1P	10	1N	1M	1L	1K	1J	1I	1H	1G	1F	1E	1D	1C	1B	1A						
*	W/L	L/B	L/W	G/R	G/O	*	*	*	*	*	*	*	*	*	*	*	*	*	*	L/W	V/W
2P	20	2N	2M	2L	2K	2J	2I	2H	2G	2F	2E	2D	2C	2B	2A						
B	G/W	G/Y	R/B	L/O	Y/R	W/G	L/Y	BR/R	G/B												
3J	3I	3H	3G	3F	3E	3D	3C	3B	3A												

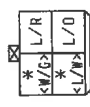

C-02 KEY REMINDER SWITCH (F)

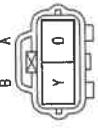

C-03 VEHICLE SPEEDOMETER SENSOR (E)

HARNESS SYMBOL : (F) (E) (R)



VEHICLE SPEEDOMETER SENSOR
 Generates a signal that is proportional to vehicle speed and sends this signal to Instrument Cluster.

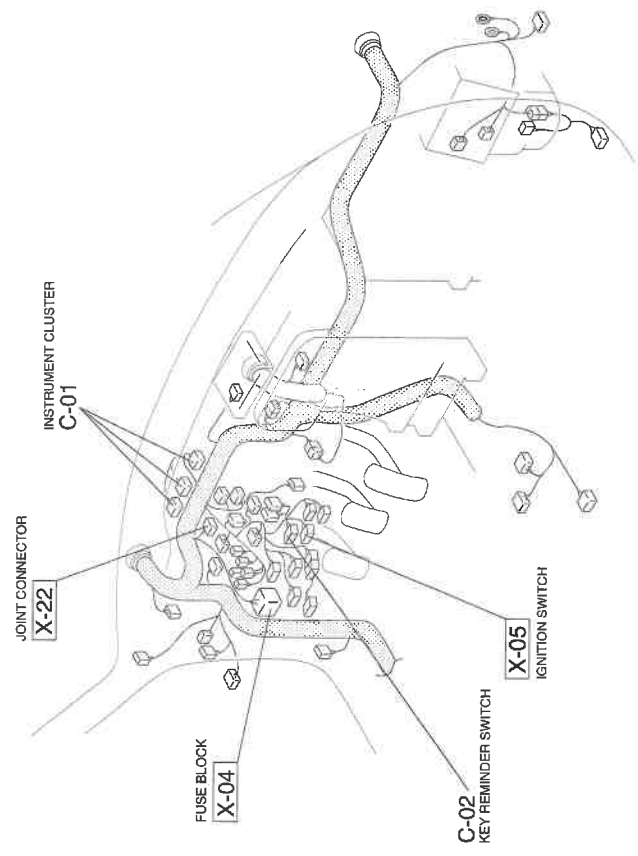

HARNESS SYMBOL : (F) (E) (R)

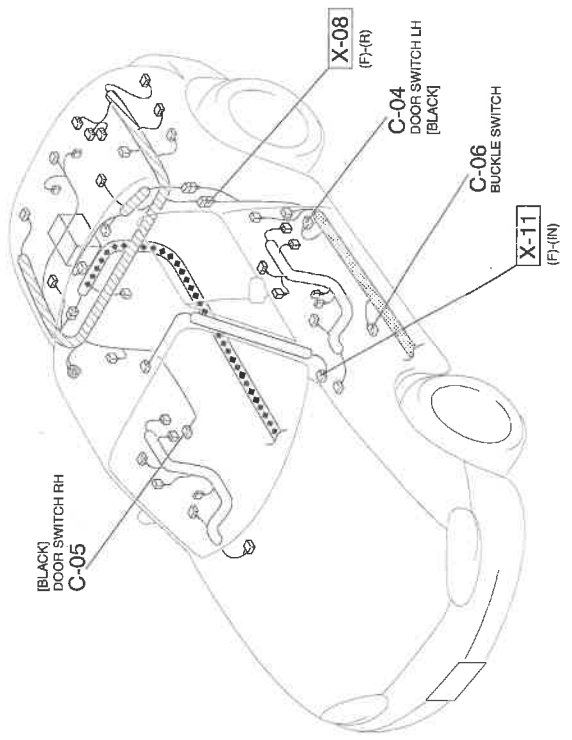
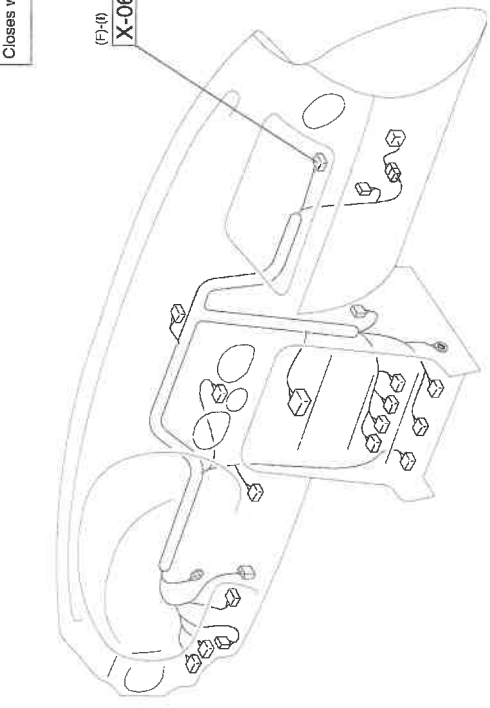
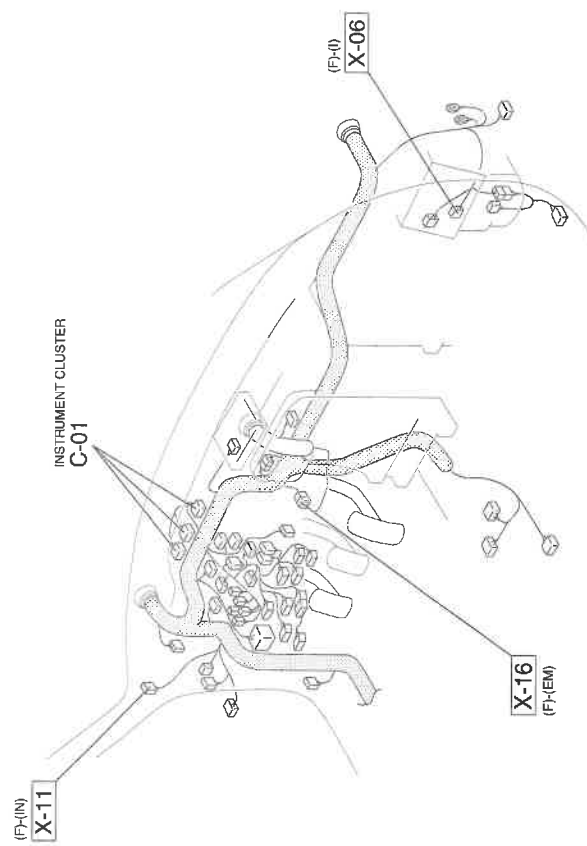
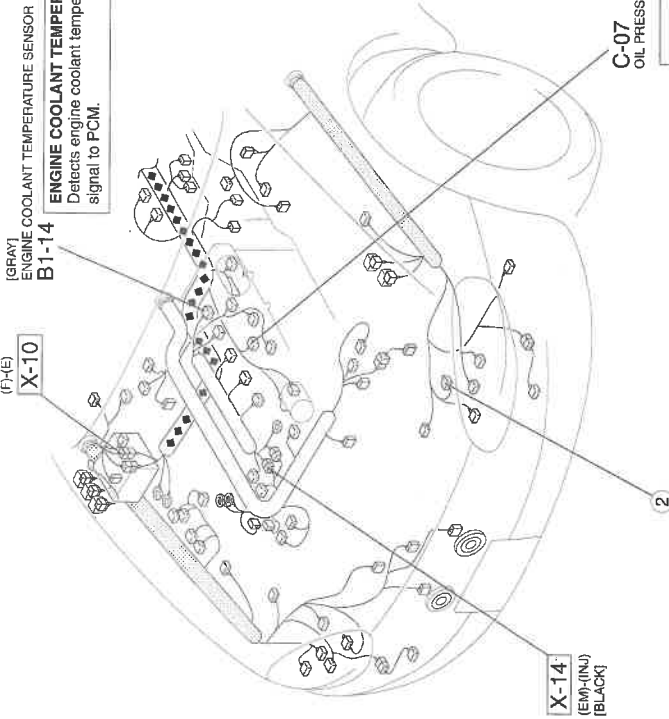

INSTRUMENT CLUSTER

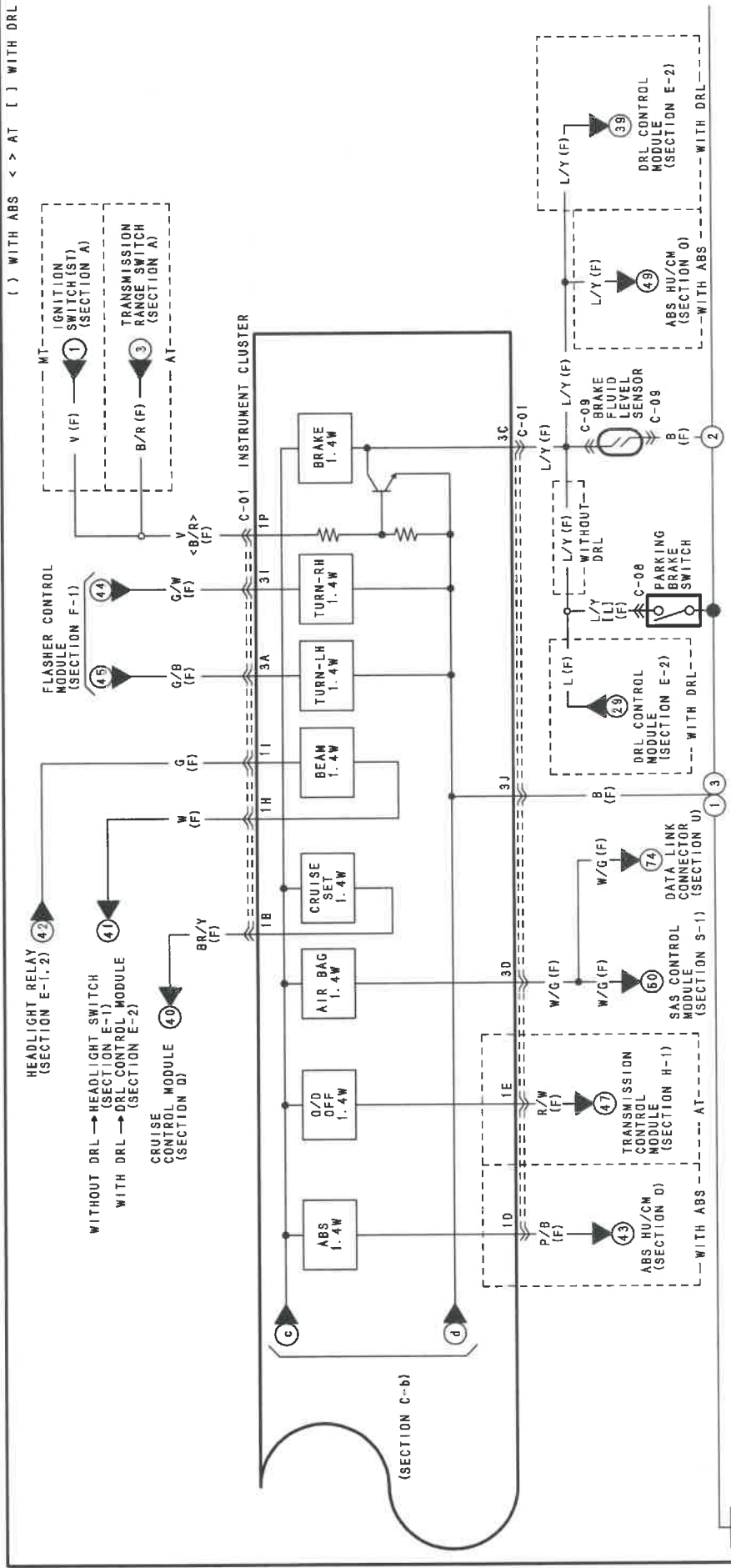

C-01 INSTRUMENT CLUSTER (F)

C-08 PARKING BRAKE SWITCH (F)

C-09 BRAKE FLUID LEVEL SENSOR (F)

V	B/L	*	Y	W/R	*	G	W	*	L/R	*	R/Y	*	B/Y	BR/Y	BR/B
1P	10	1N	1M	1L	1K	1J	1I	1H	1G	1F	1E	1D	1C	1B	1A

B	G/W	GY/R	R/B	L/O	Y/R	W/G	L/Y	BR/R	G/B
3J	3I	3H	3G	3F	3E	3D	3C	3B	3A

HARNES SYMBOL :  (F)  (E)  (R)

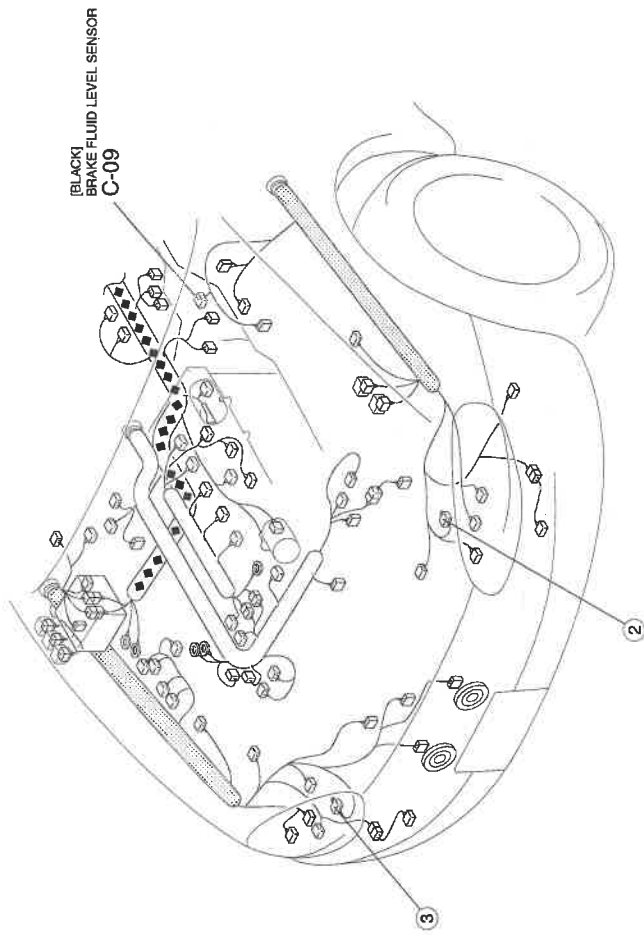

BLACK
BRAKE FLUID LEVEL SENSOR
C-09

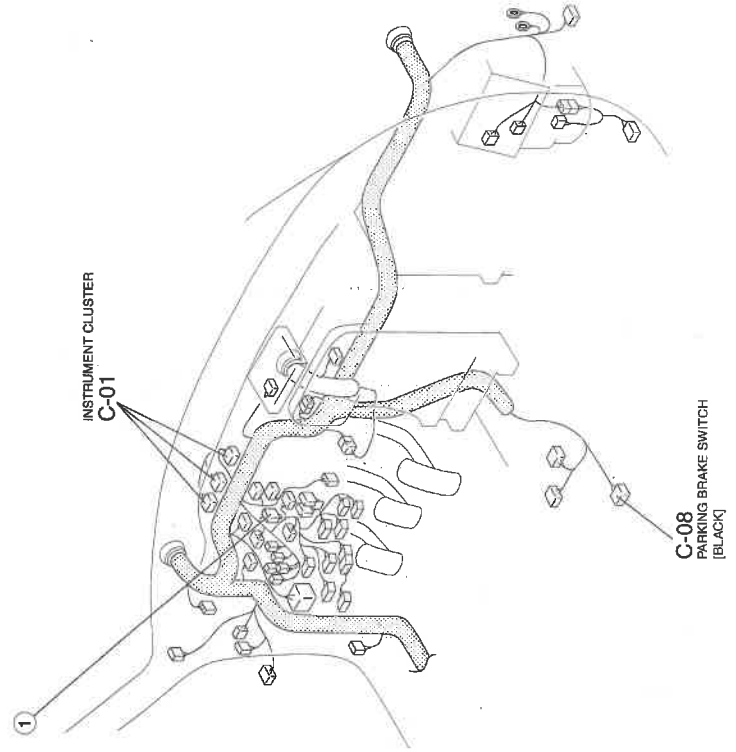

INSTRUMENT CLUSTER
C-01

C-08
PARKING BRAKE SWITCH
[BLACK]

() WITH DRL

WINDSHIELD WIPER AND WASHER

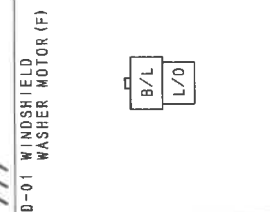
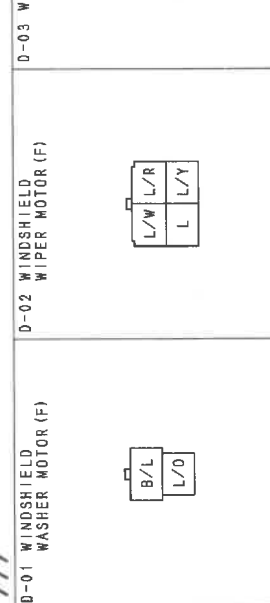
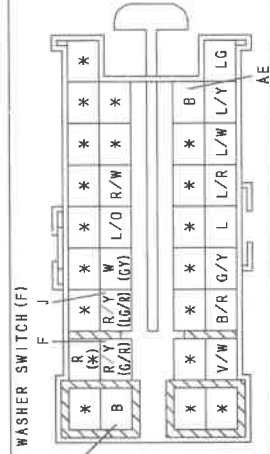
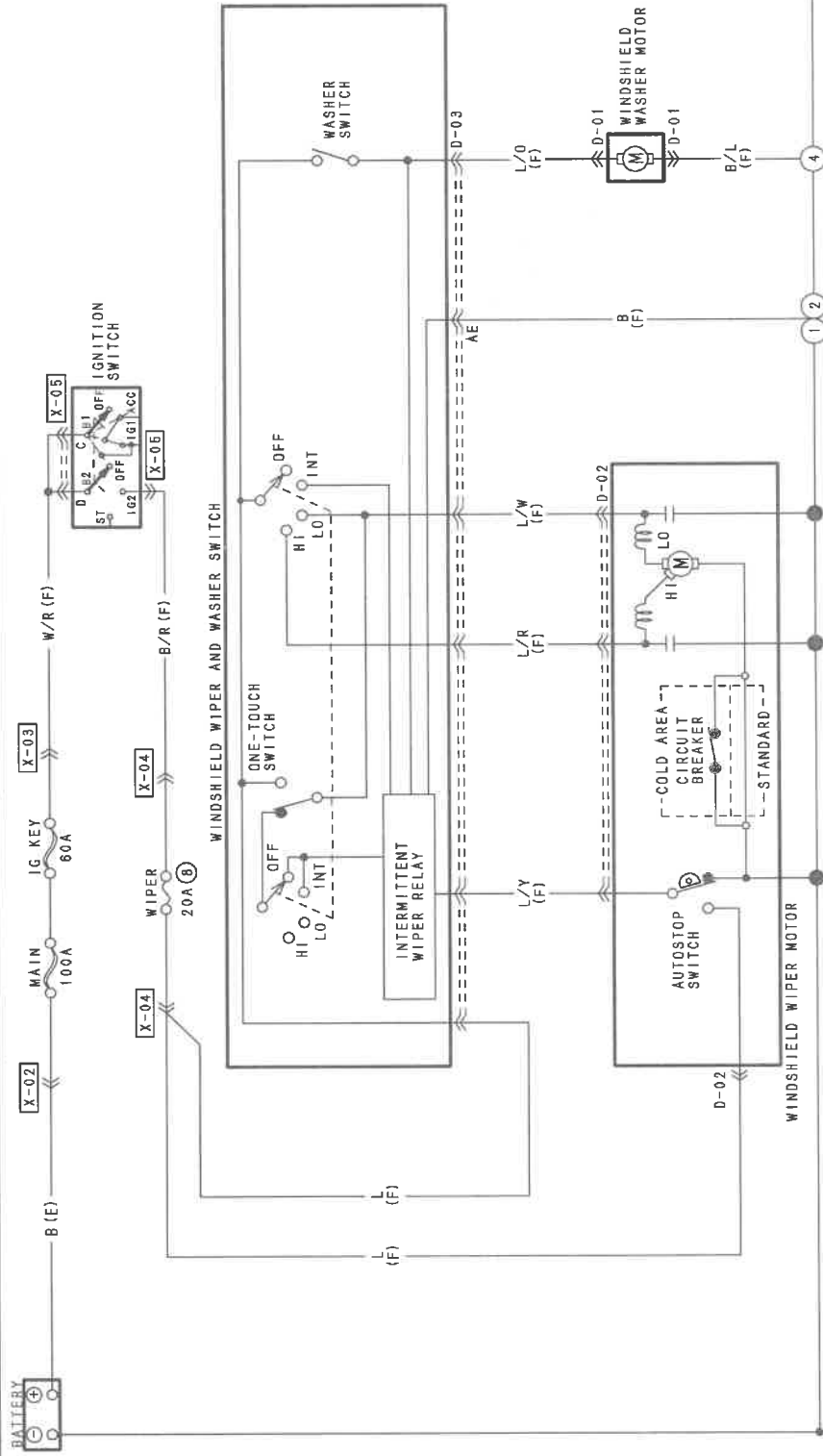

HEADLIGHT (WITHOUT DRL)

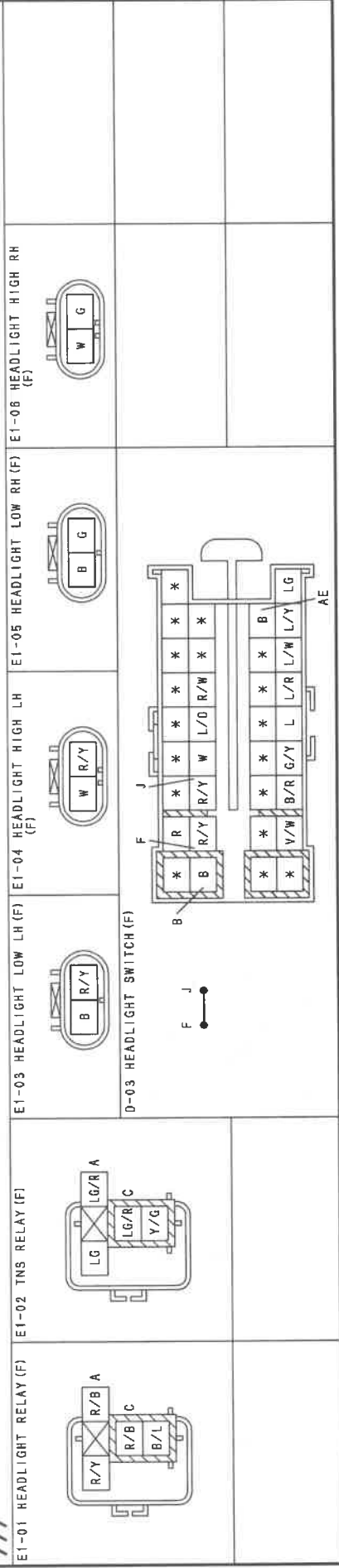
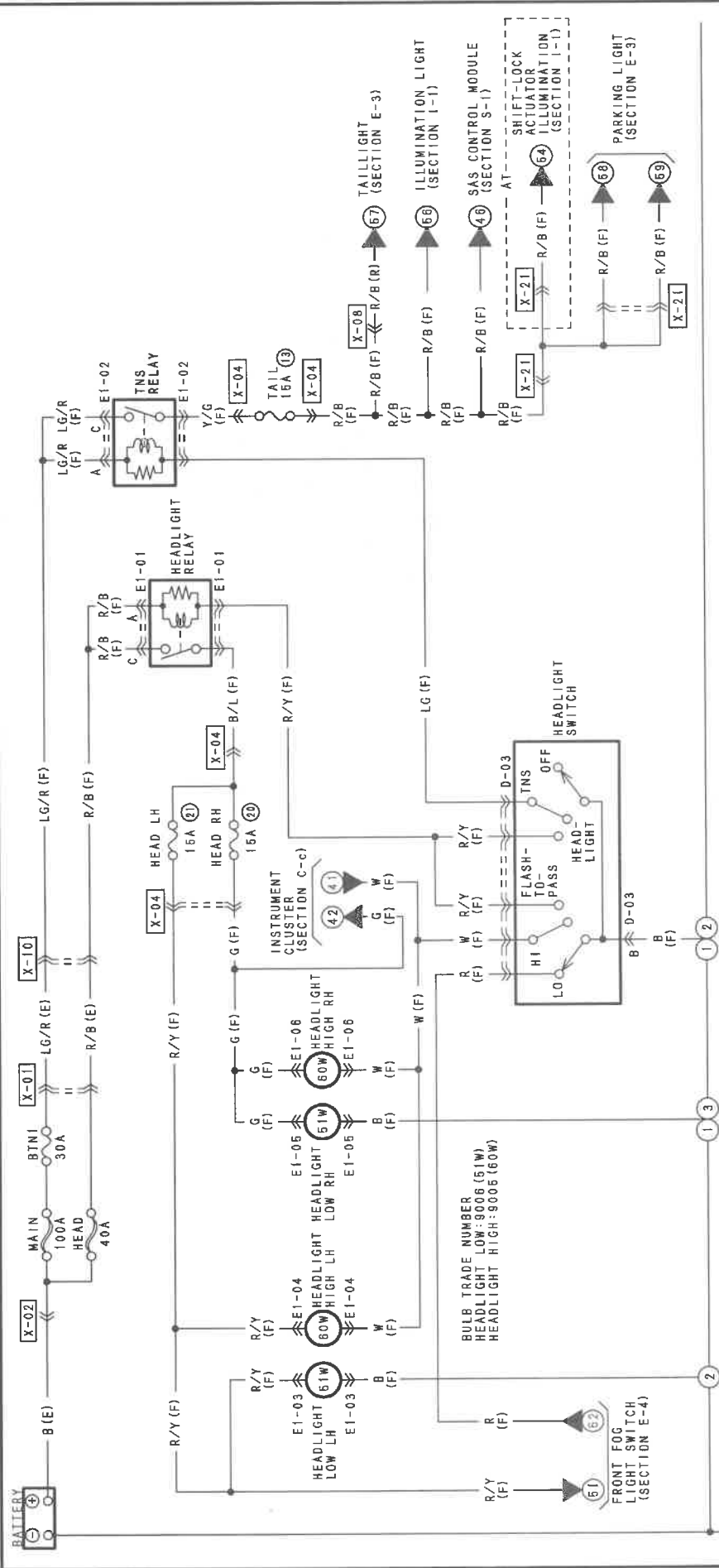

HEADLIGHT (WITH DRL)

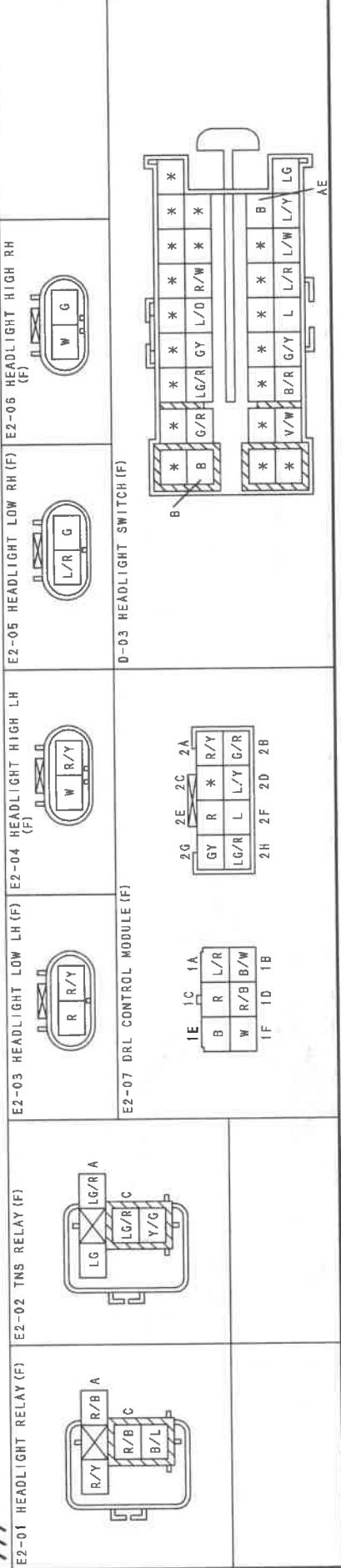
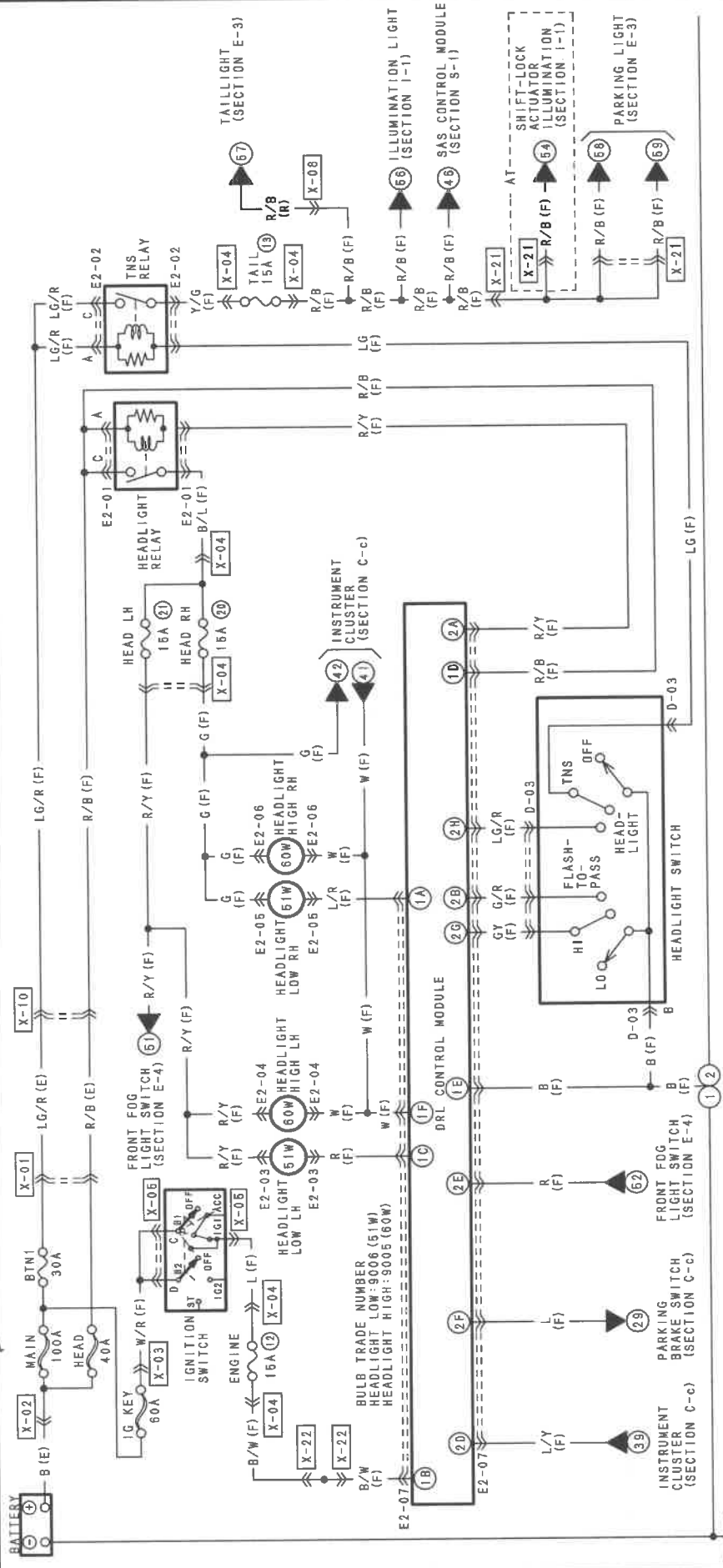

HARNES SYMBOL : [Pattern] (F) [Pattern] (E) [Pattern] (R)

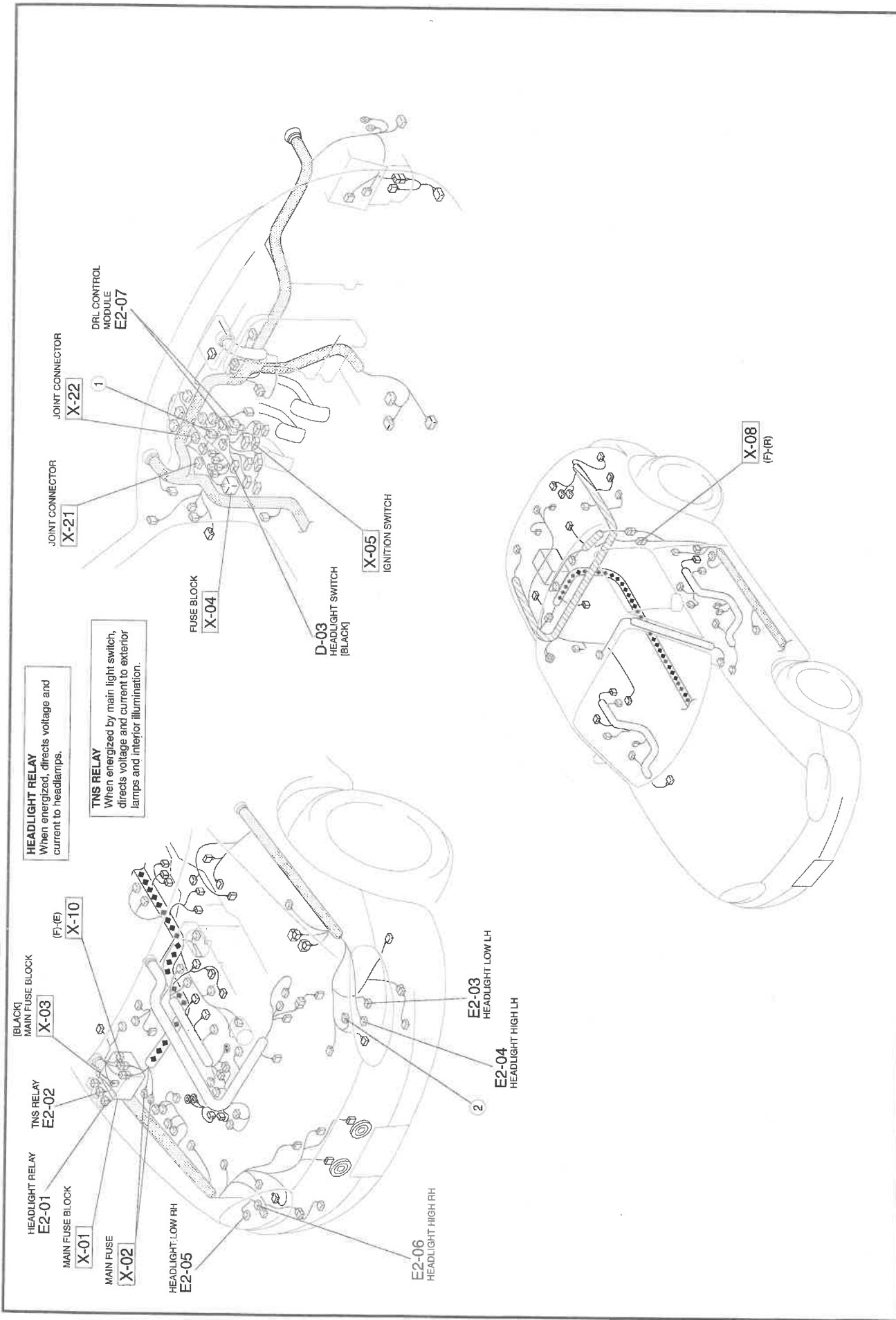

FRONT SIDE MARKER LIGHT / LICENSE PLATE AND TRUNK COMPARTMENT LIGHT / PARKING LIGHT / TAILLIGHT

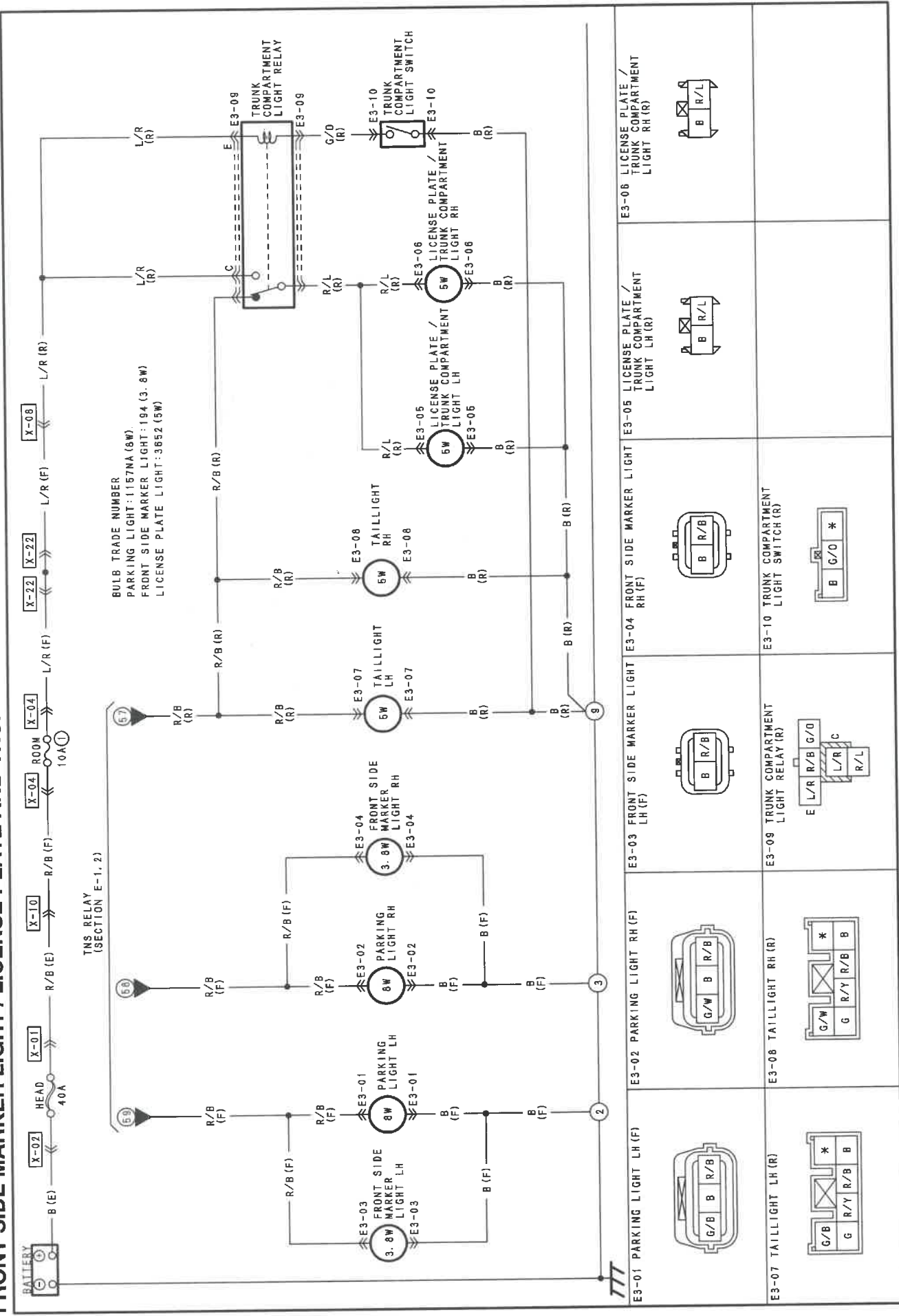

HARNES SYMBOL : (F) (E) (R)

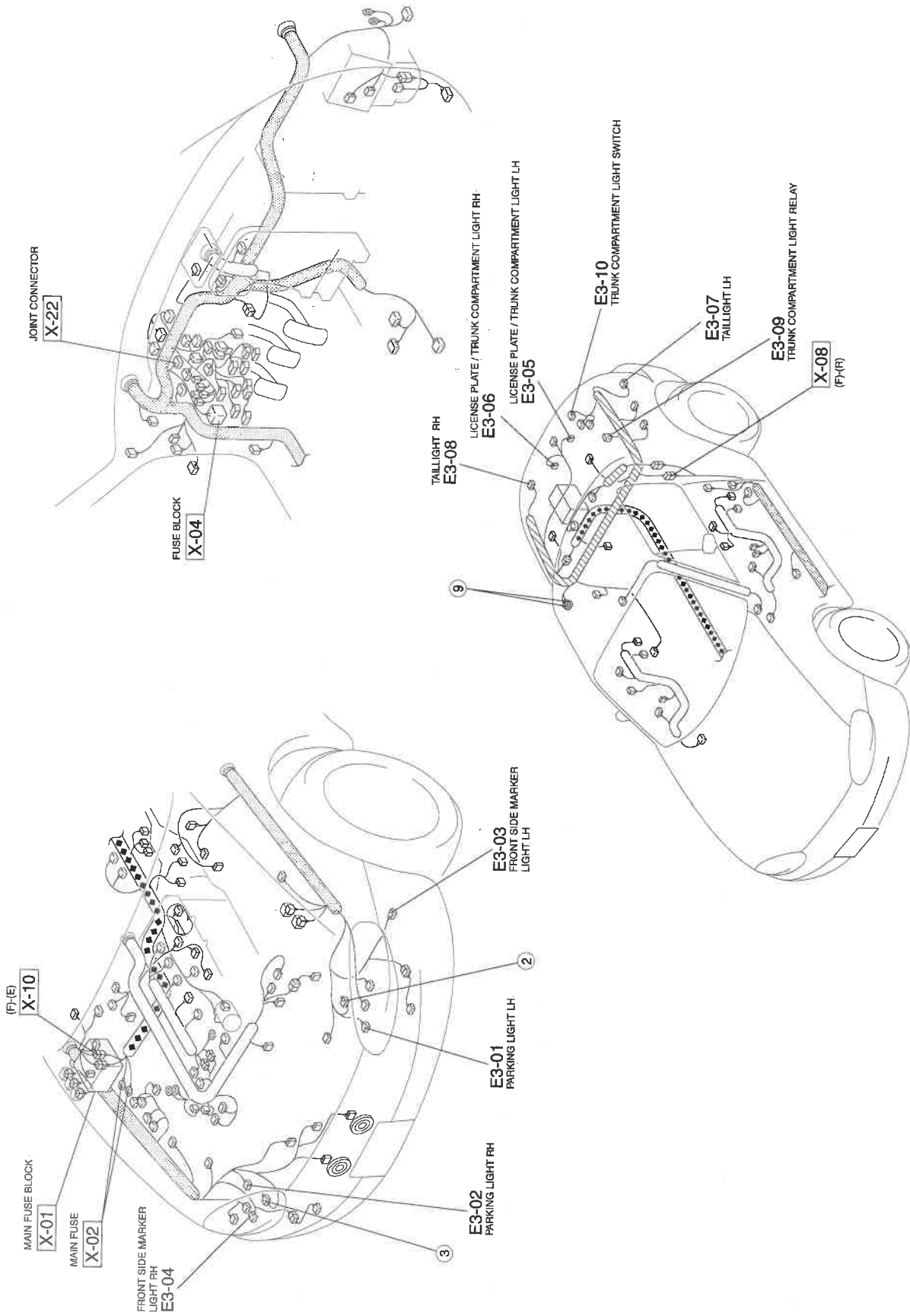

FRONT FOG LIGHT

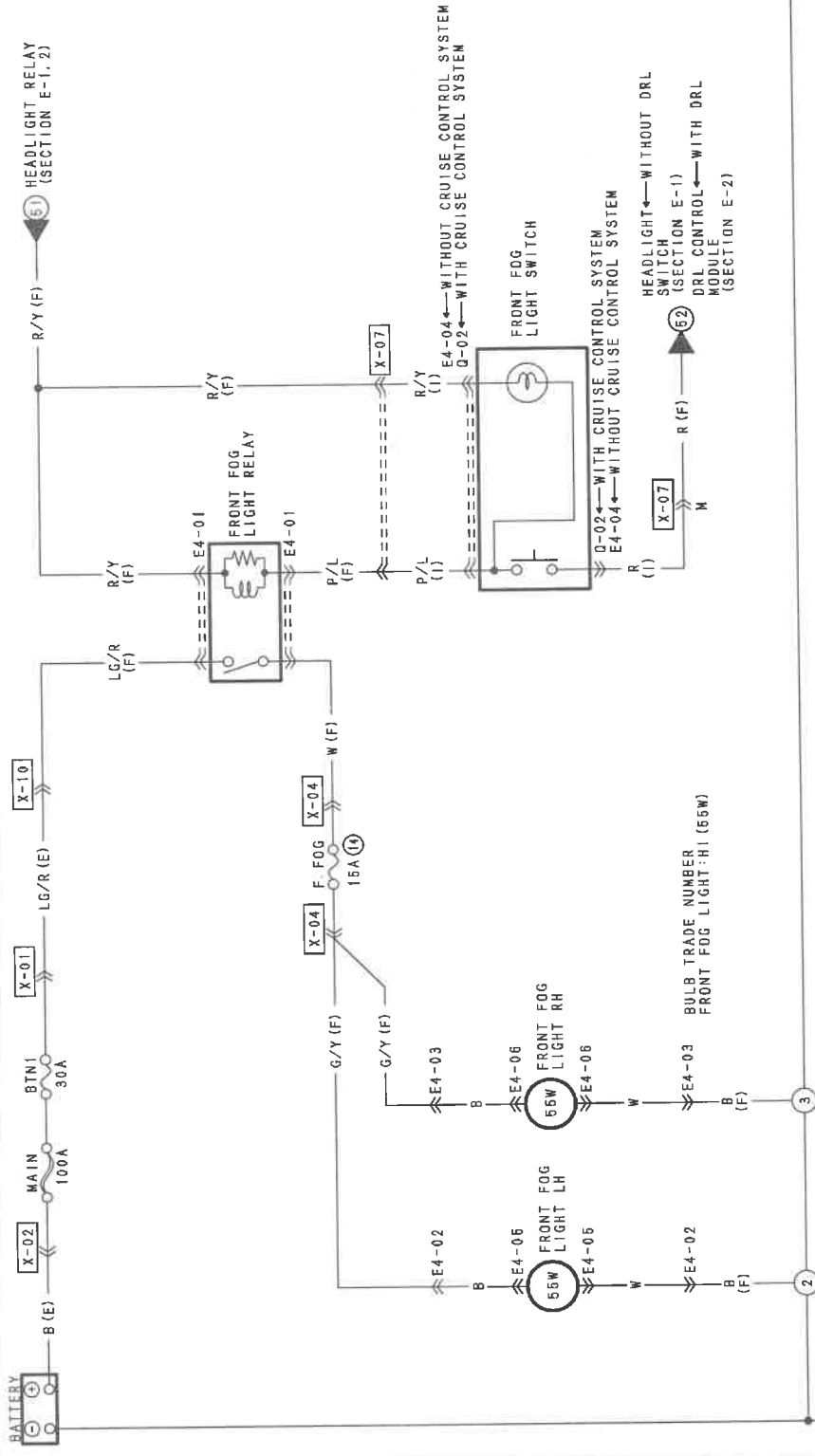

<p>E4-01 FRONT FOG LIGHT RELAY (F)</p>	<p>E4-02 FRONT (F) - SHORT CORD</p>	<p>E4-03 FRONT (F) - SHORT CORD</p>	<p>E4-04 FRONT FOG LIGHT SWITCH (I)</p>
<p>E4-05 FRONT FOG LIGHT LH (SHORT CORD)</p>	<p>E4-06 FRONT FOG LIGHT RH (SHORT CORD)</p>	<p>(WITH CRUISE CONTROL SYSTEM)</p>	<p>(WITHOUT CRUISE CONTROL SYSTEM)</p>

HARNESS SYMBOL :  (F)  (E)  (R)

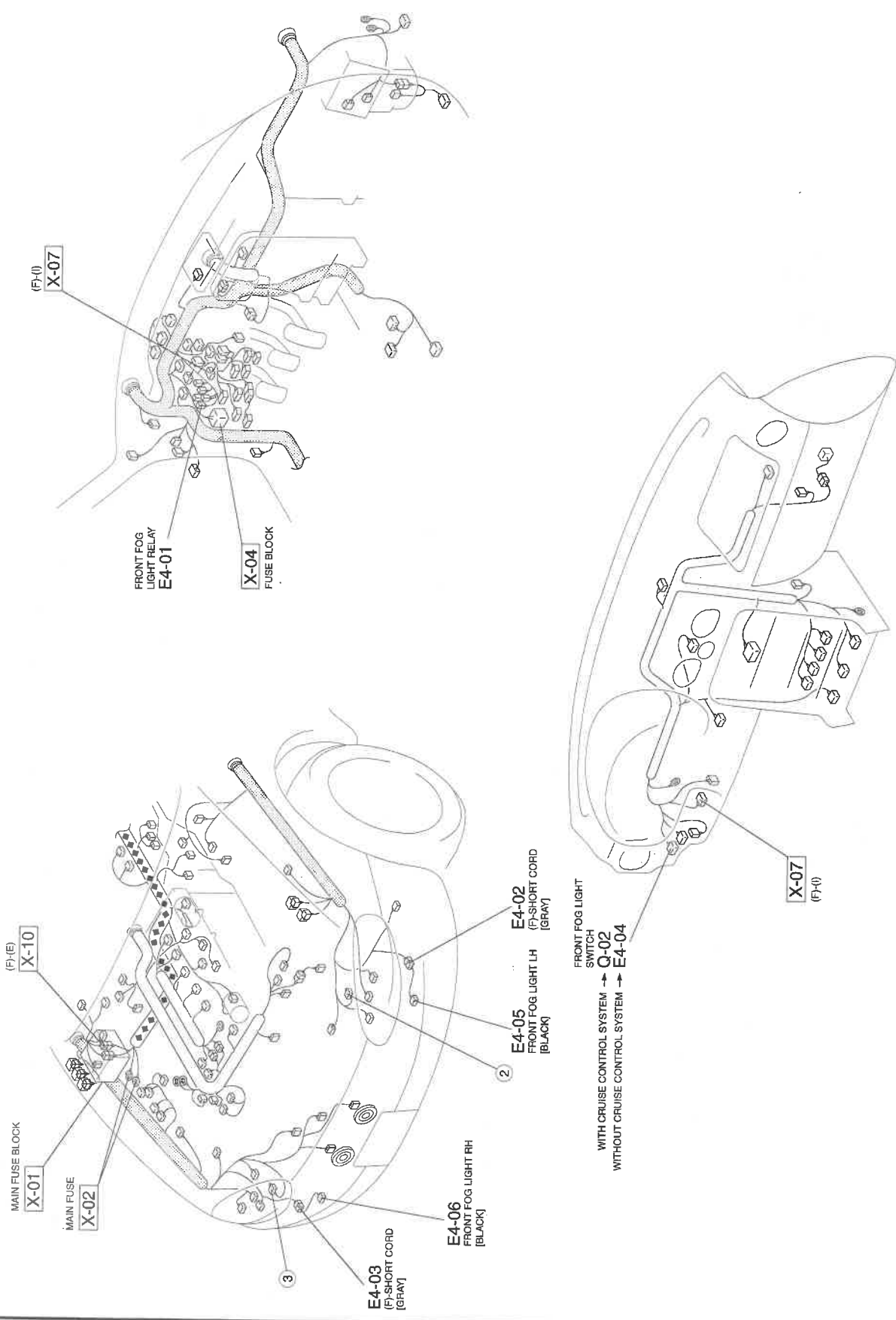

TURN AND HAZARD WARNING LIGHT

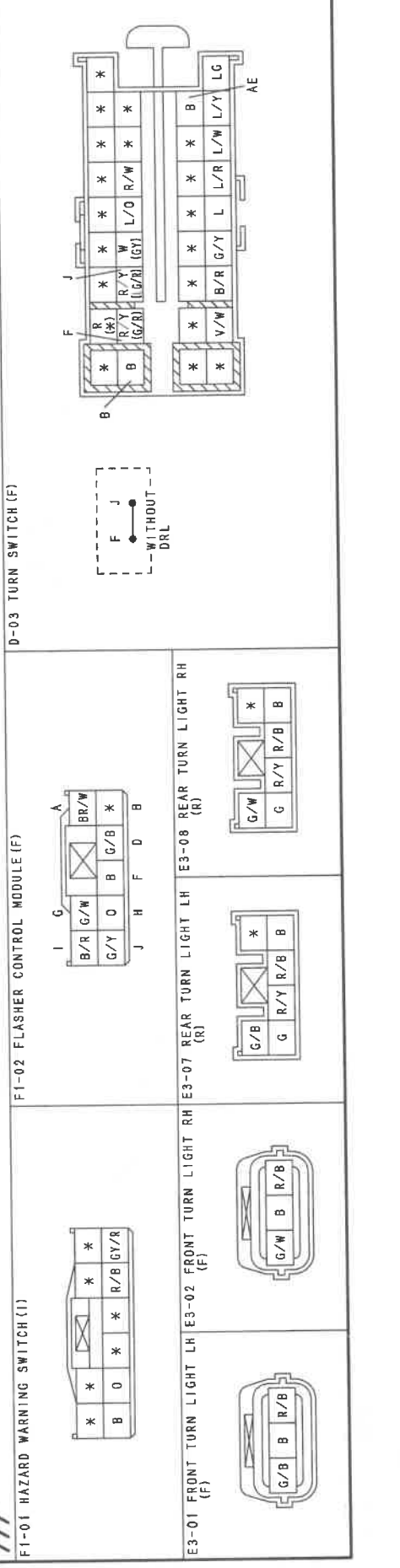
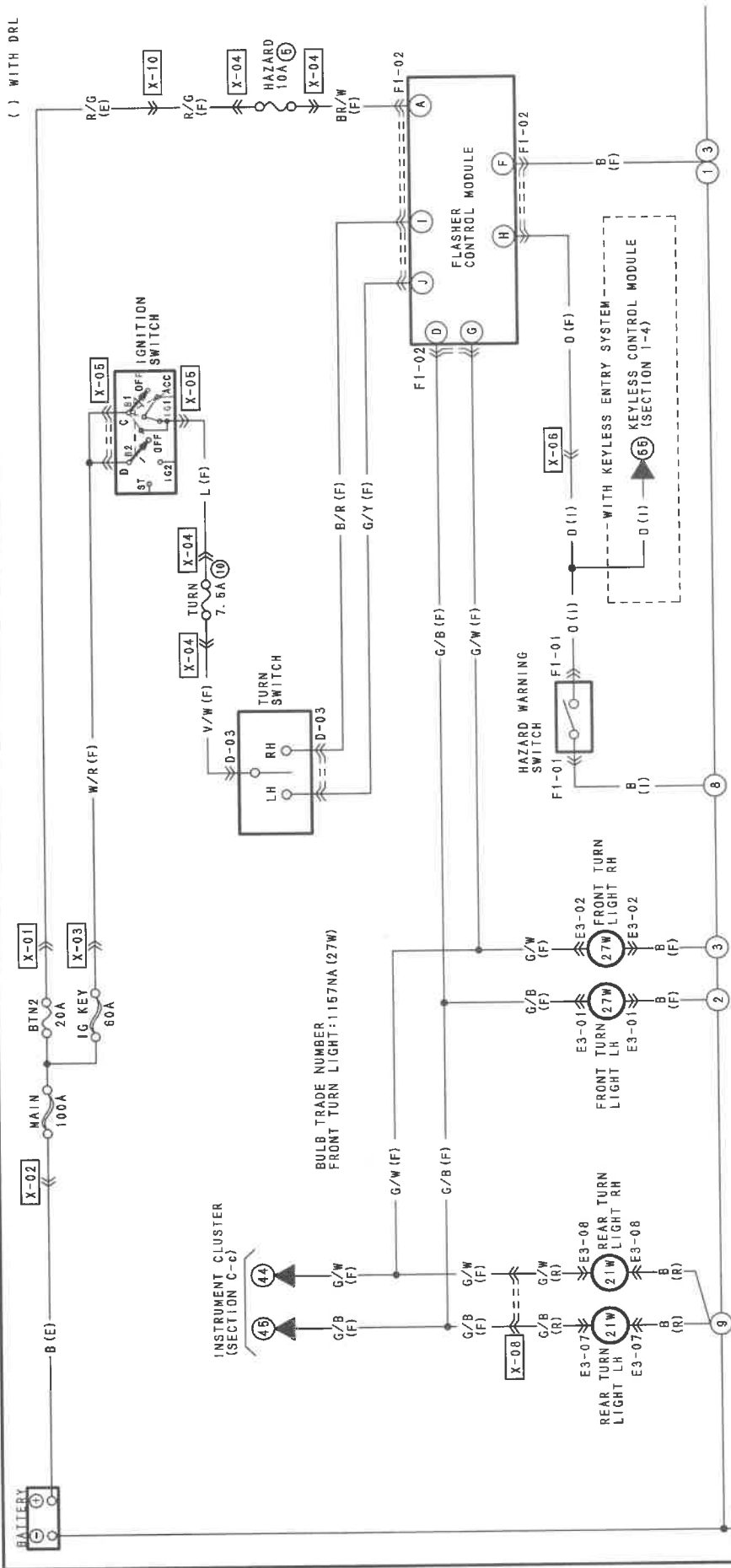

HARNES SYMBOL : (F) ◆◆◆ (E) (R)

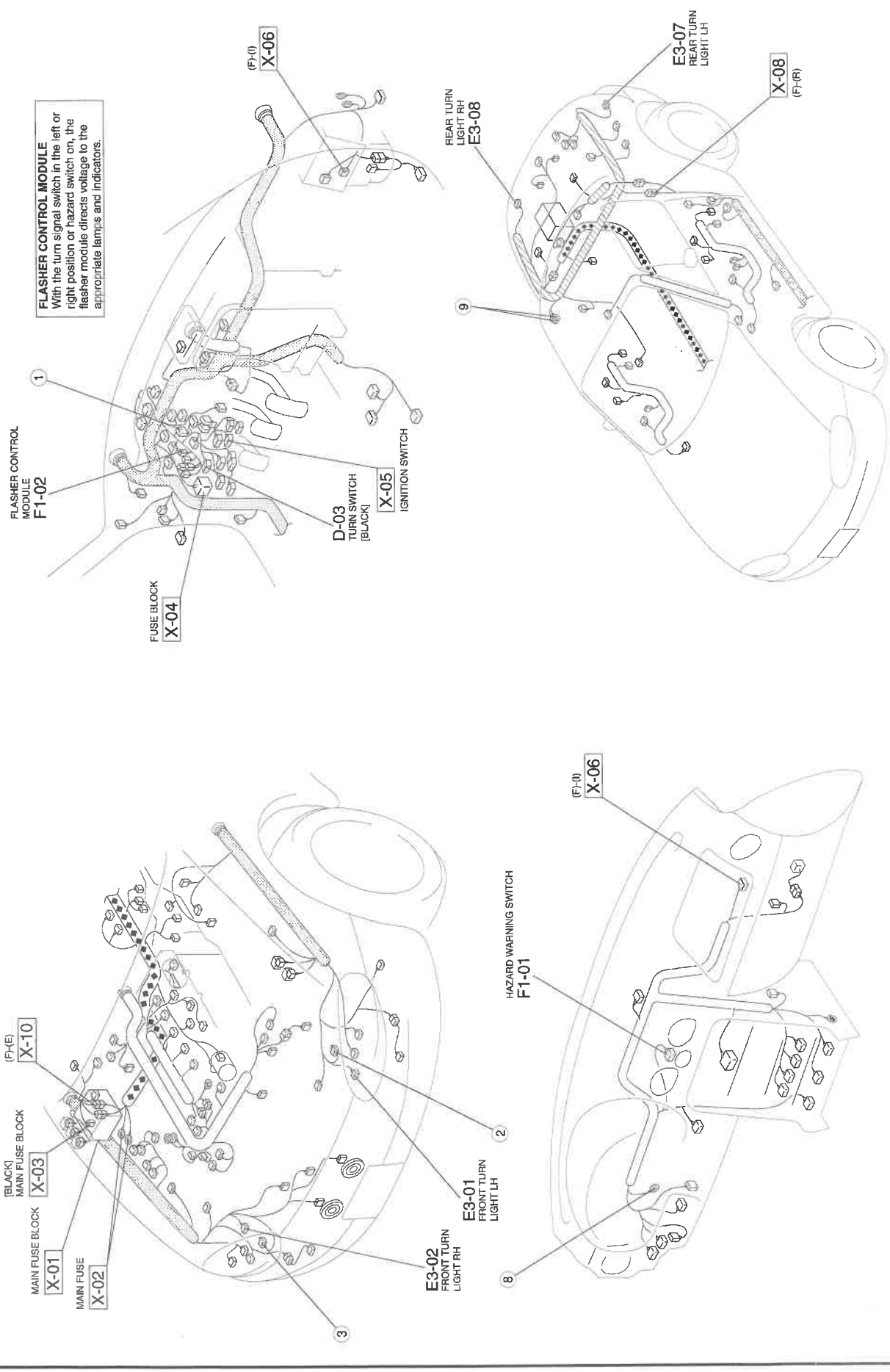

BACK-UP LIGHT / BRAKE LIGHT / HIGH-MOUNT BRAKE LIGHT / HORN

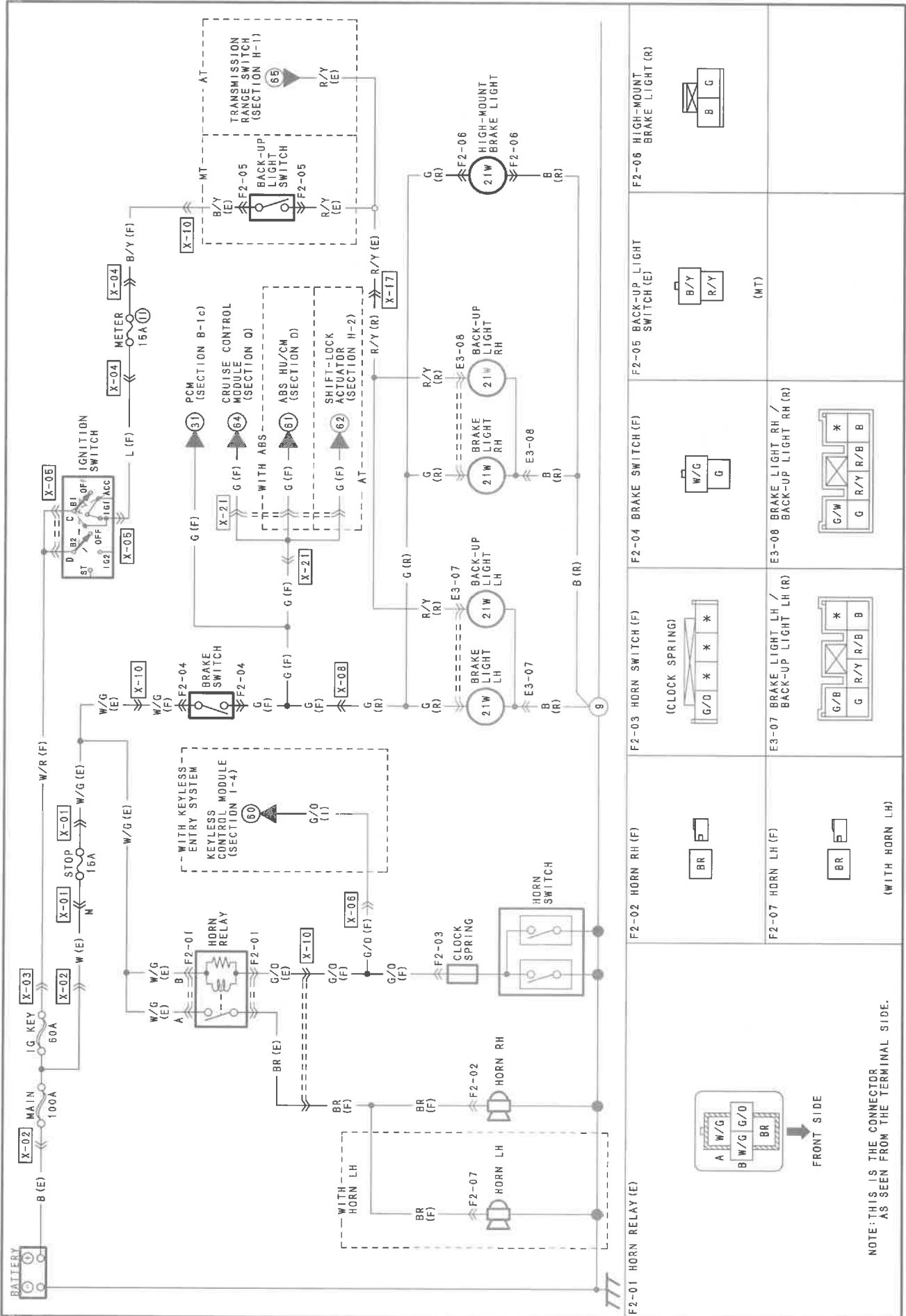

F2-01 HORN RELAY (E)	F2-02 HORN RH (F)	F2-03 HORN SWITCH (F)	F2-04 BRAKE SWITCH (F)	F2-05 BACK-UP LIGHT SWITCH (E)	F2-06 HIGH-MOUNT BRAKE LIGHT (R)
	BR	(CLOCK SPRING) G/D * * *	W/G G	B/Y R/Y	B G
	F2-07 HORN LH (F)	E3-07 BRAKE LIGHT LH / BACK-UP LIGHT LH (R)	E3-08 BRAKE LIGHT RH / BACK-UP LIGHT RH (R)	(MT)	
	BR	G/B G R/Y R/B B	G/W G R/Y R/B B		
	(WITH HORN LH)				

NOTE: THIS IS THE CONNECTOR AS SEEN FROM THE TERMINAL SIDE.

HARNES SYMBOL : (F) (E) (R)

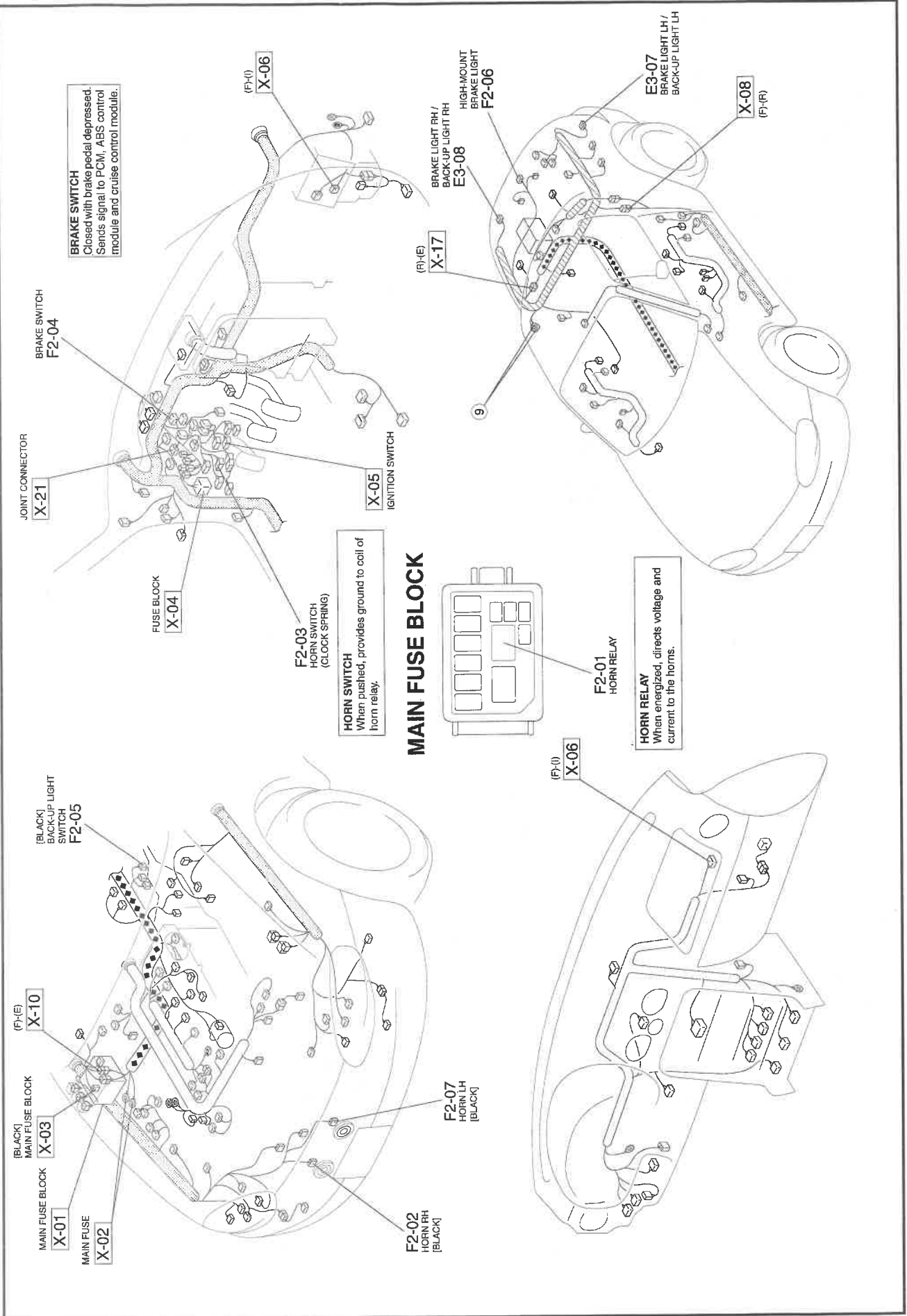

CONDENSER FAN SYSTEM / HEATER AND AIR CONDITIONER

G

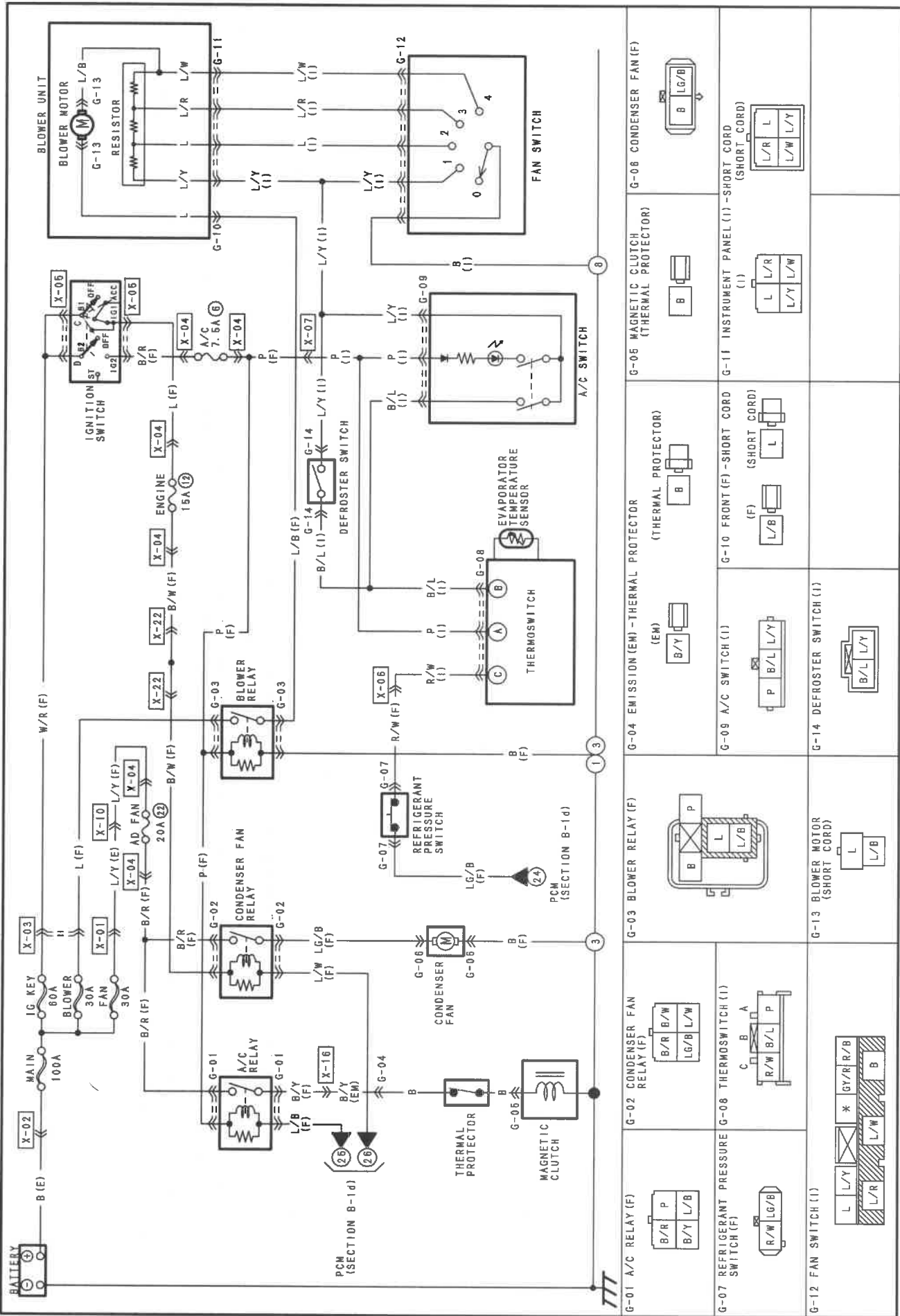

HARNES SYMBOL : (F) (E) (R)

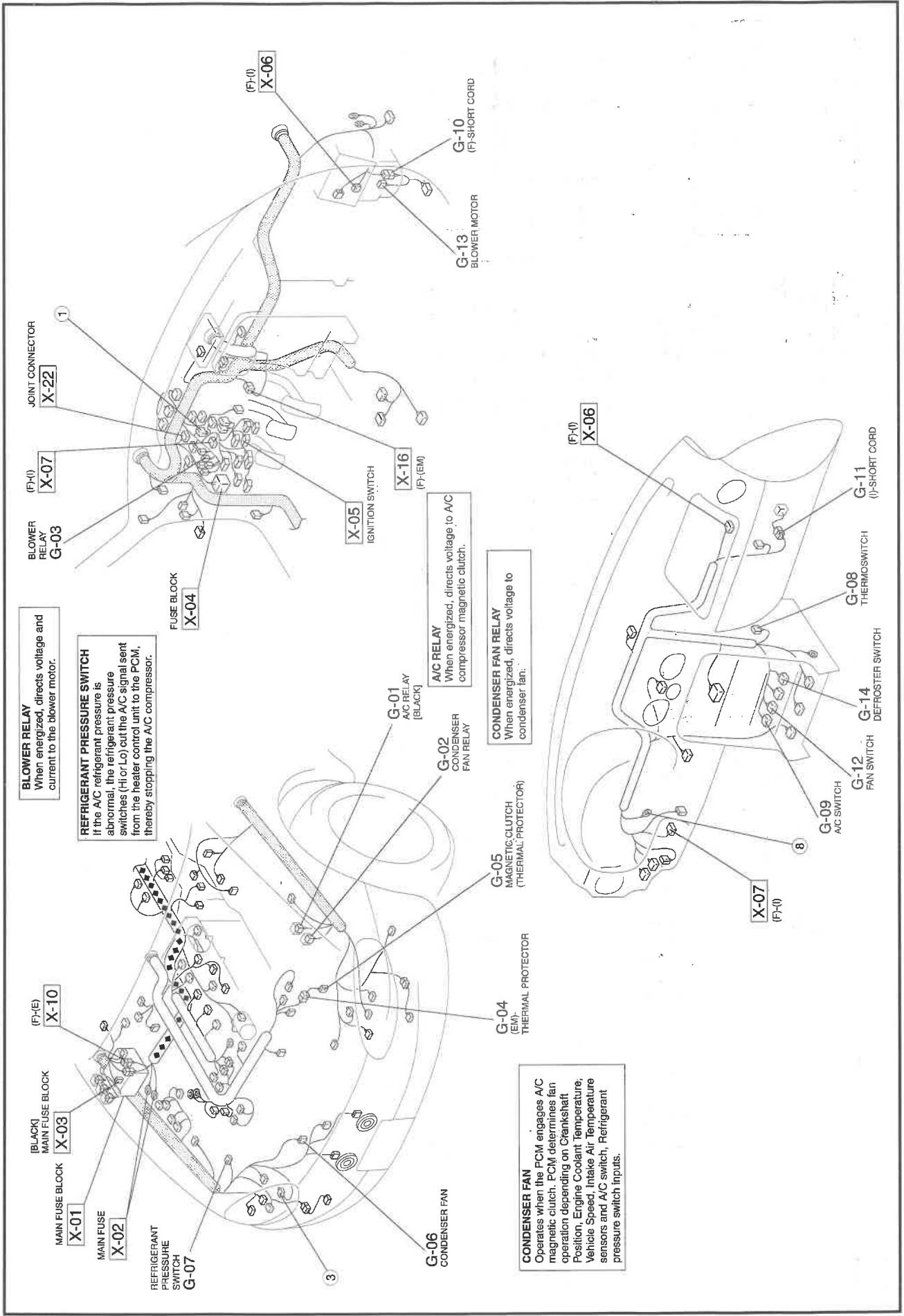

HARNESS SYMBOL : (F) (E) (R)

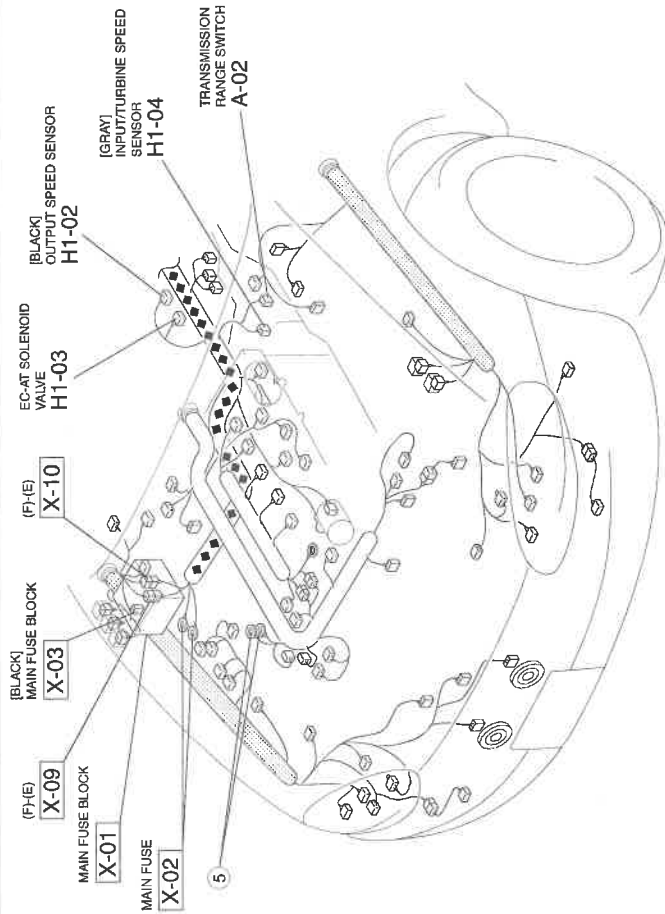

INPUT TURBINE SPEED SENSOR
 The frequency from this sensor supplies the PCM with turbine shaft speed signal. This signal is used in determining line pressure and torque converter engagement schedules.

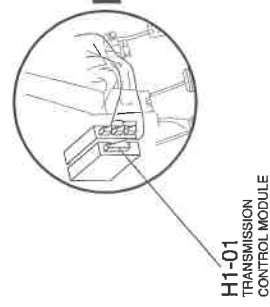
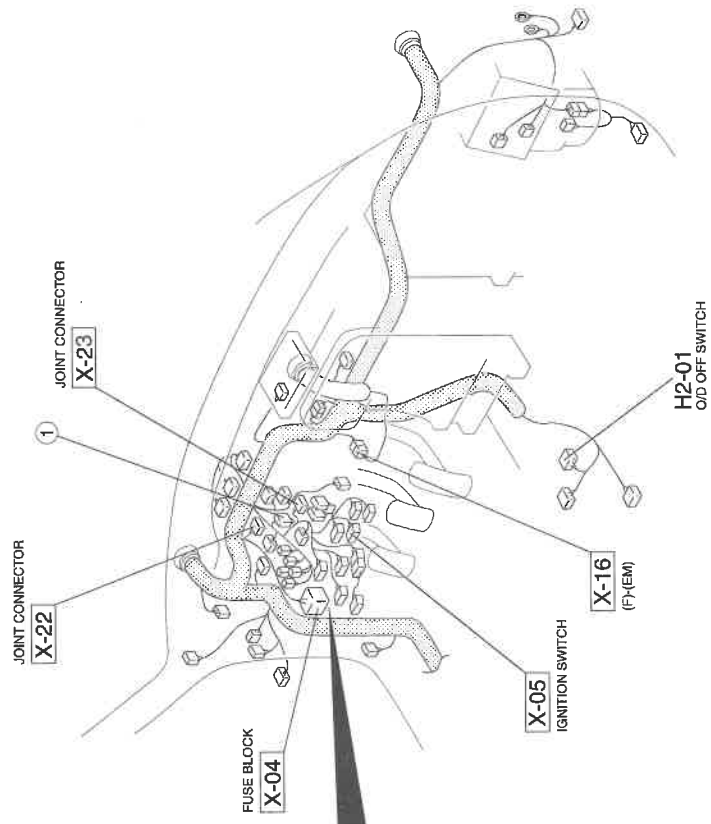

HARNES SYMBOL : (F) (E) (R)

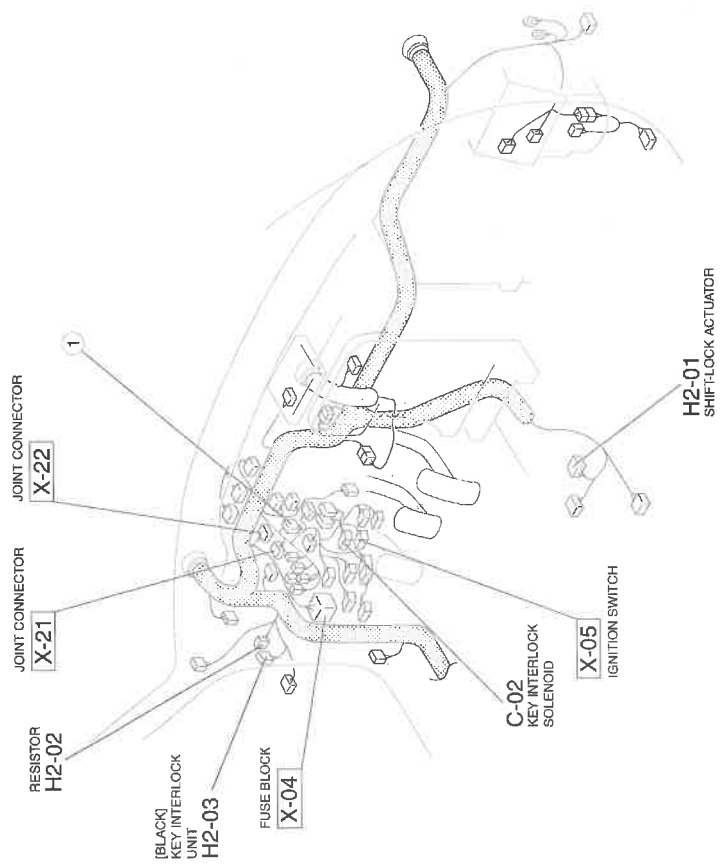
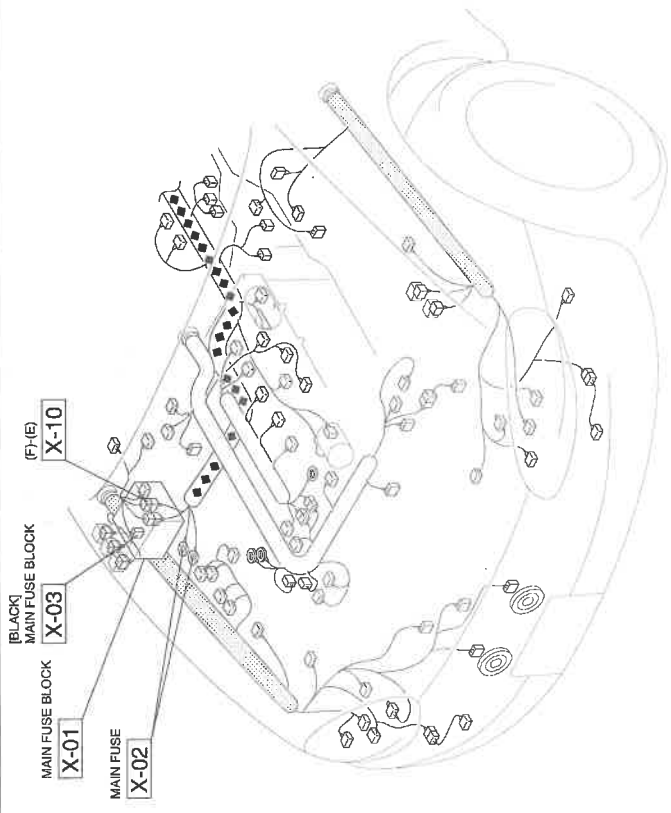

ILLUMINATION LIGHT

I-1

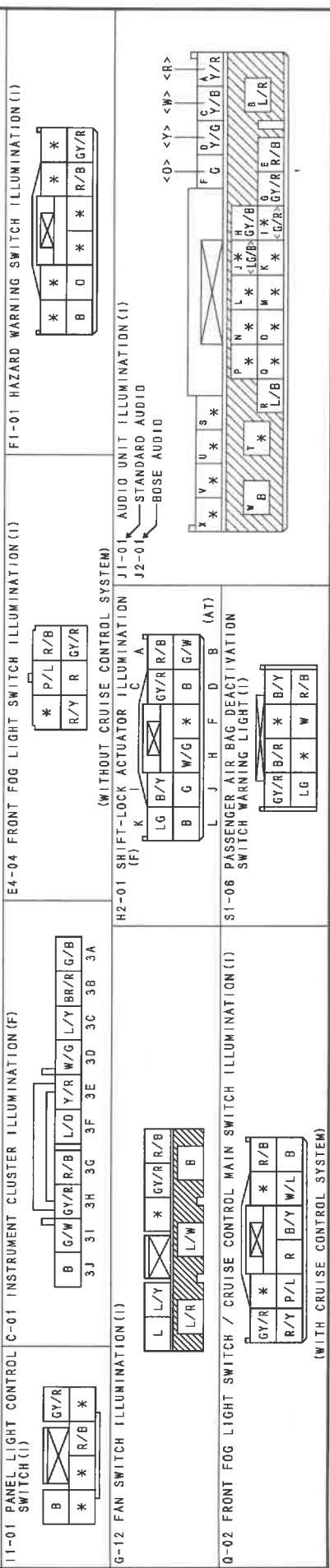
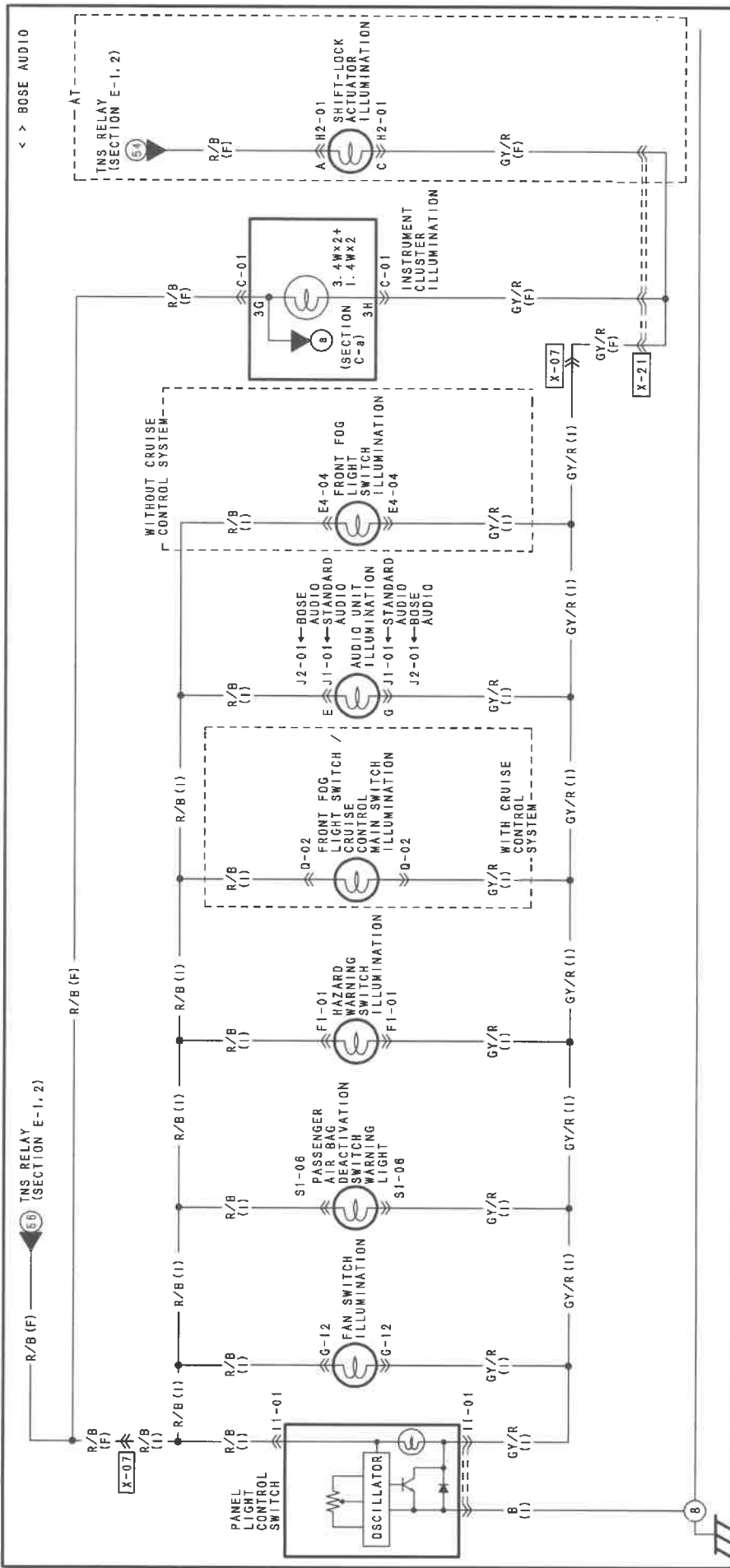

HARNES SYMBOL : (F) (E) (R)

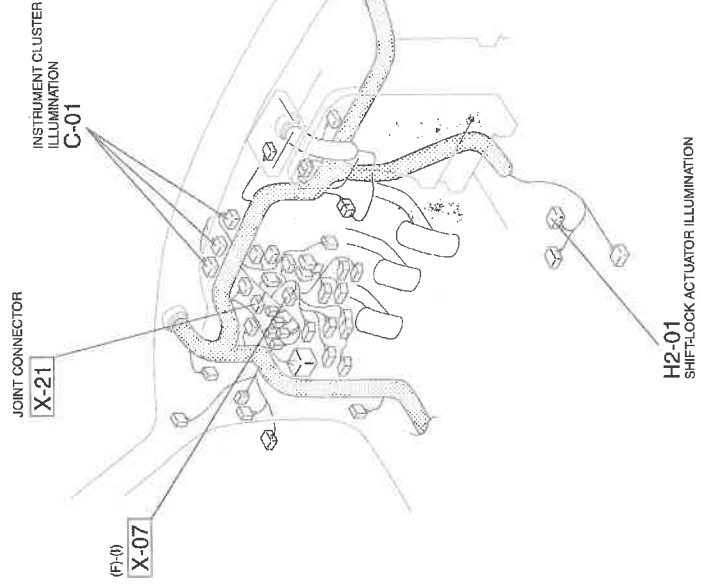
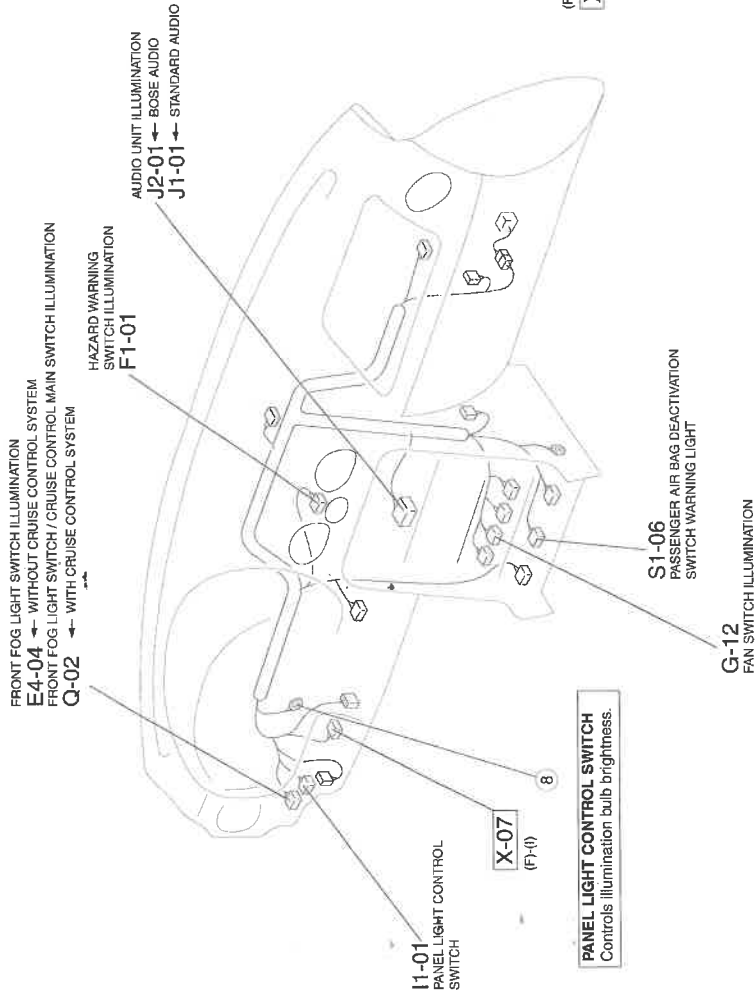

HARNES SYMBOL : (F) (E) (R)

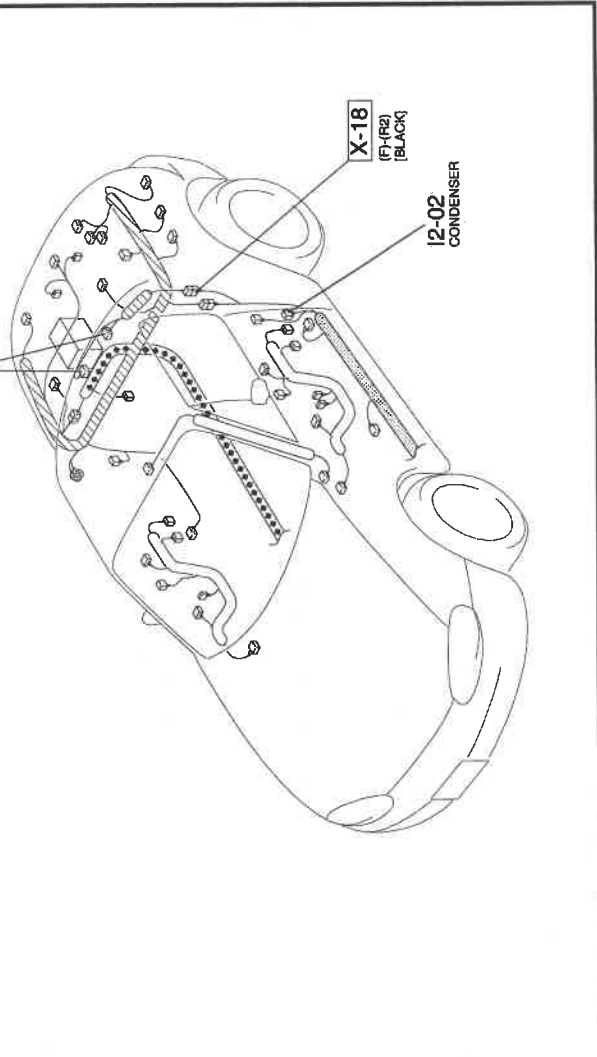
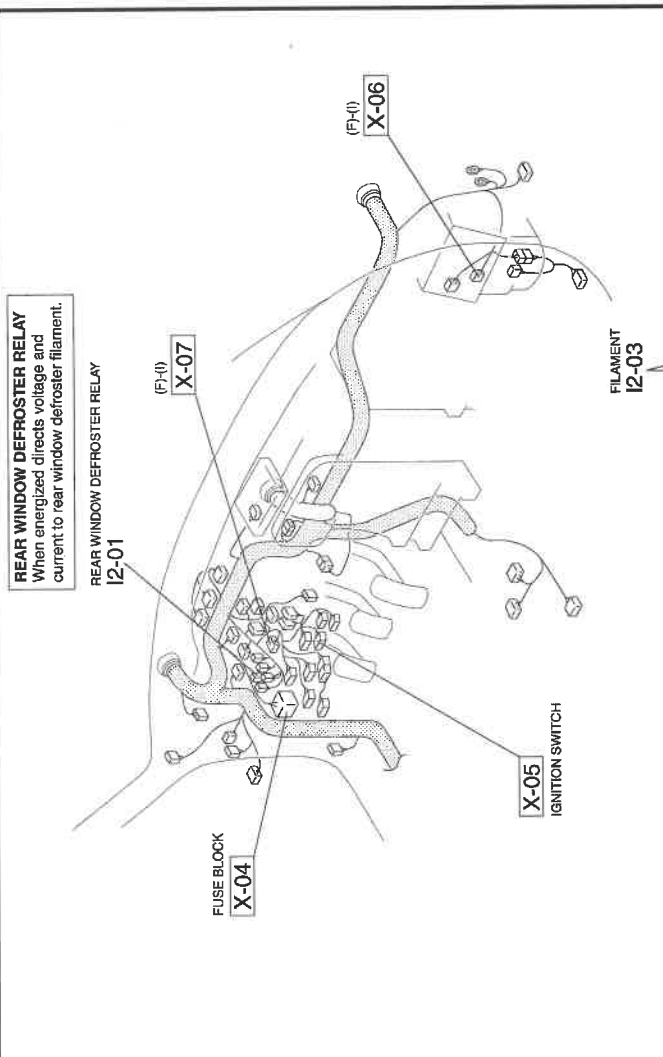
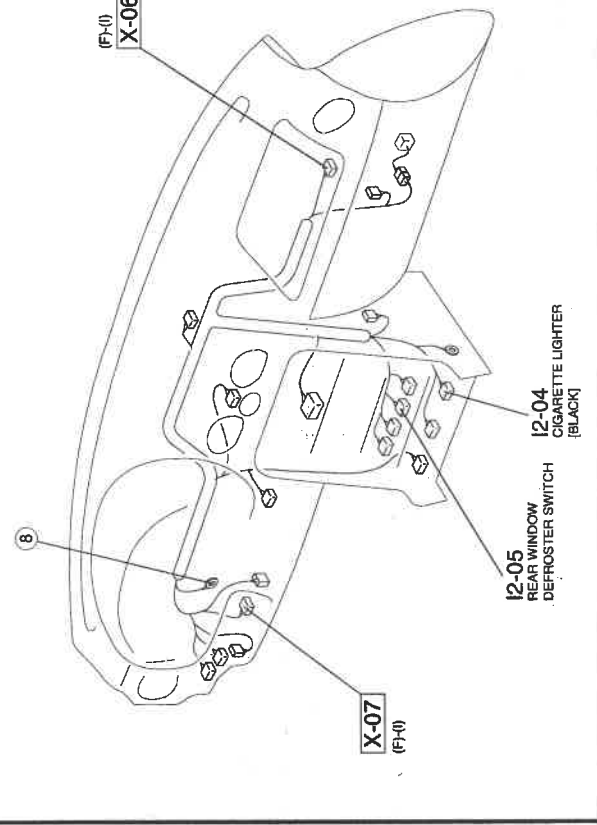
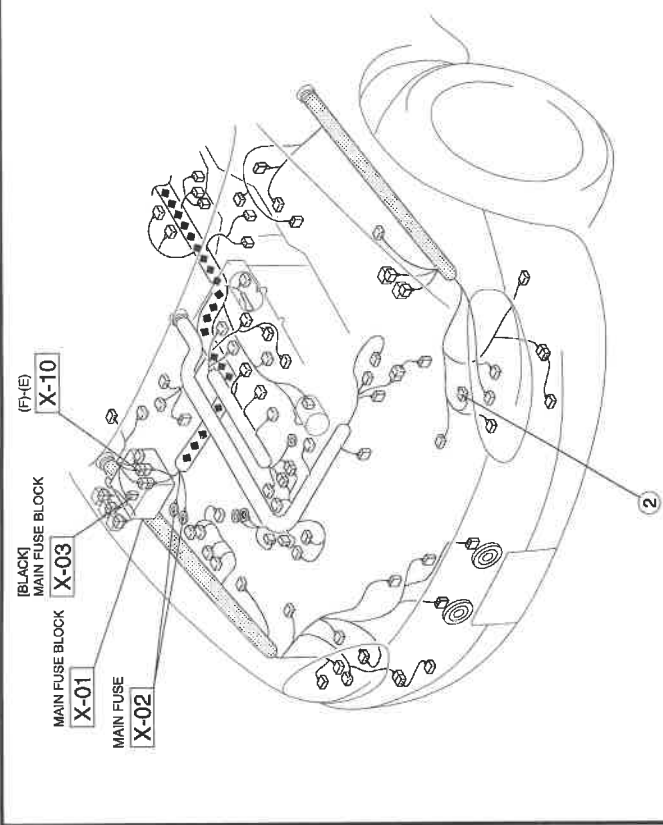

INTERIOR LIGHT

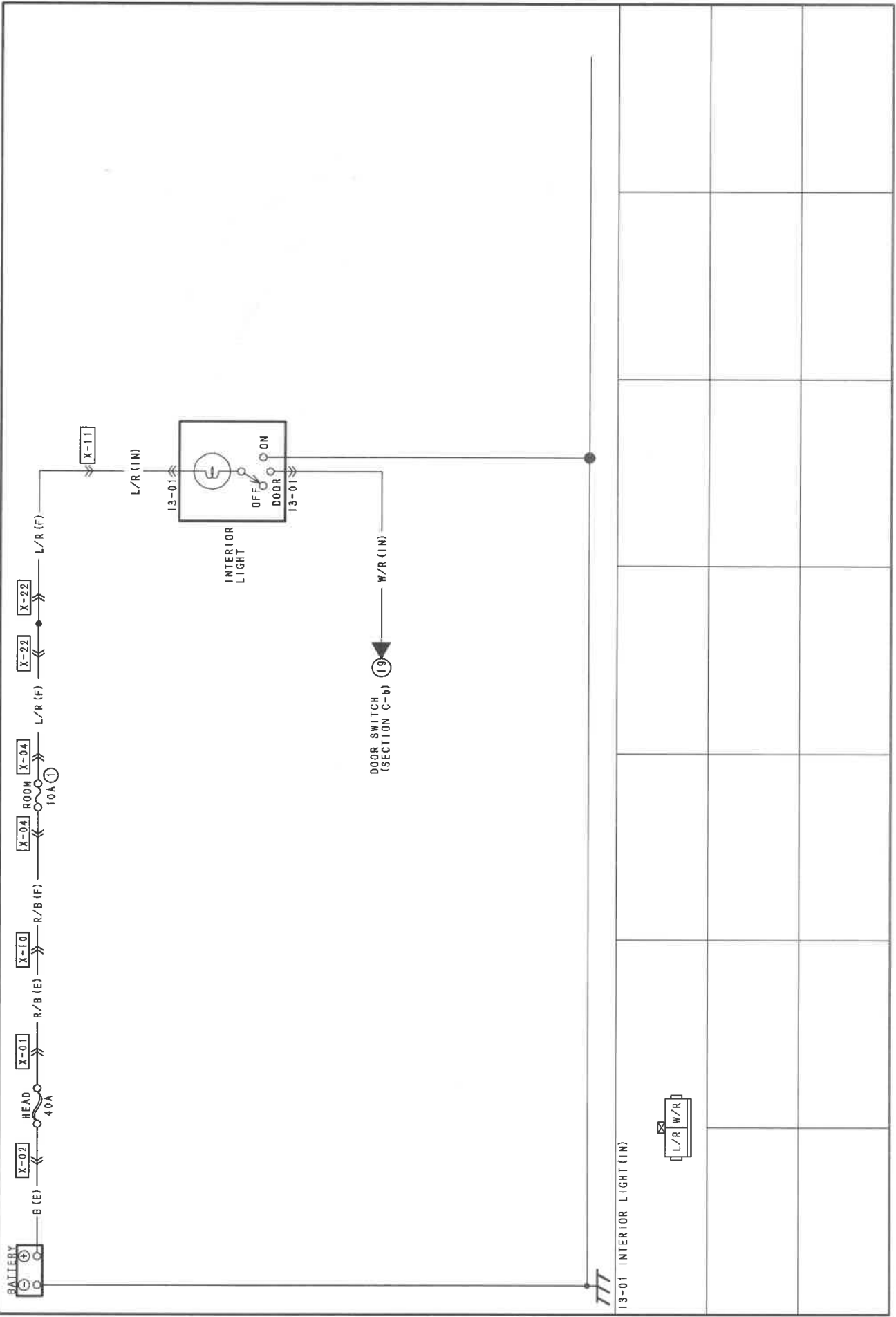

HARNES SYMBOL : (F) (E) (R)

MAIN FUSE BLOCK
X-01

MAIN FUSE
X-02

(F)-(E)
X-10

JOINT CONNECTOR
X-22

(F)-(N)
X-11

FUSE BLOCK
X-04

INTERIOR LIGHT
I3-01

X-11
(F)-(N)

HARNES SYMBOL : [Pattern] (F) [Pattern] (E) [Pattern] (R)

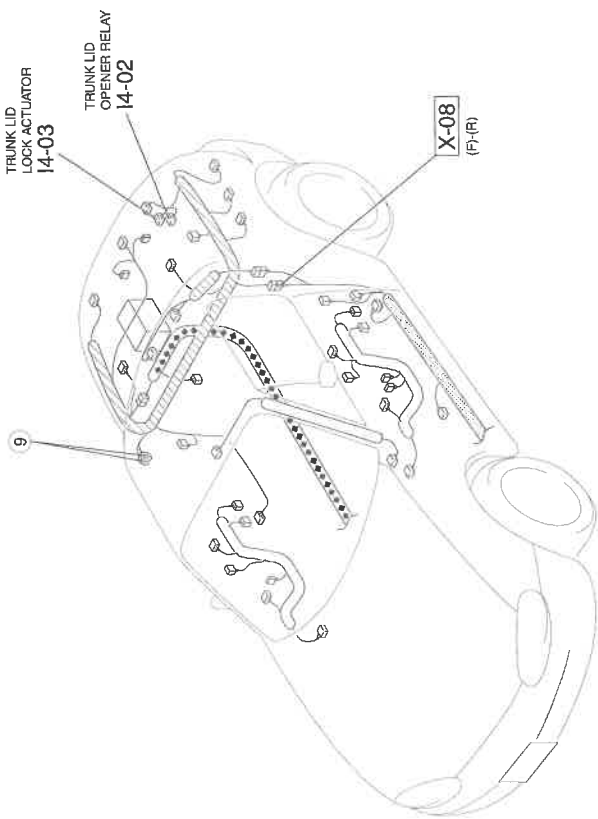
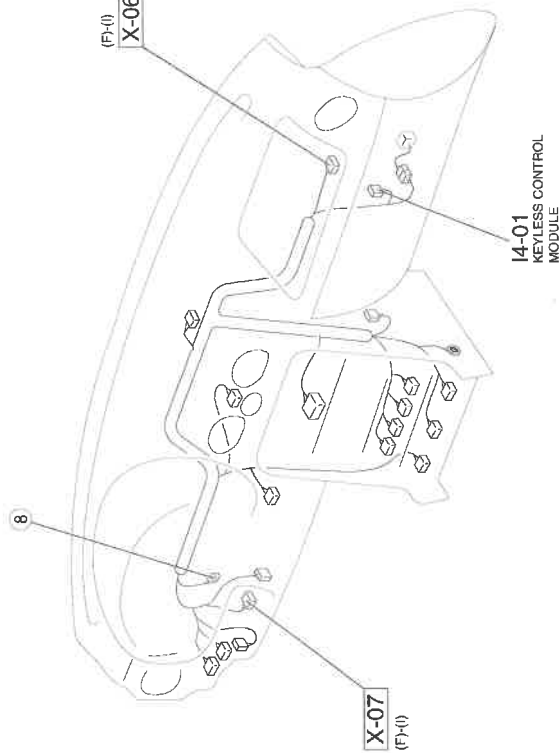
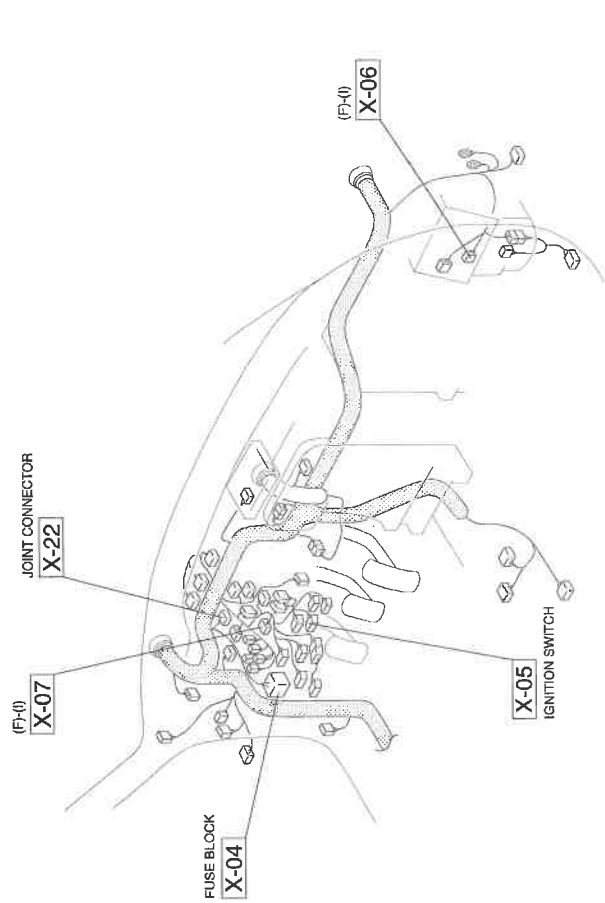
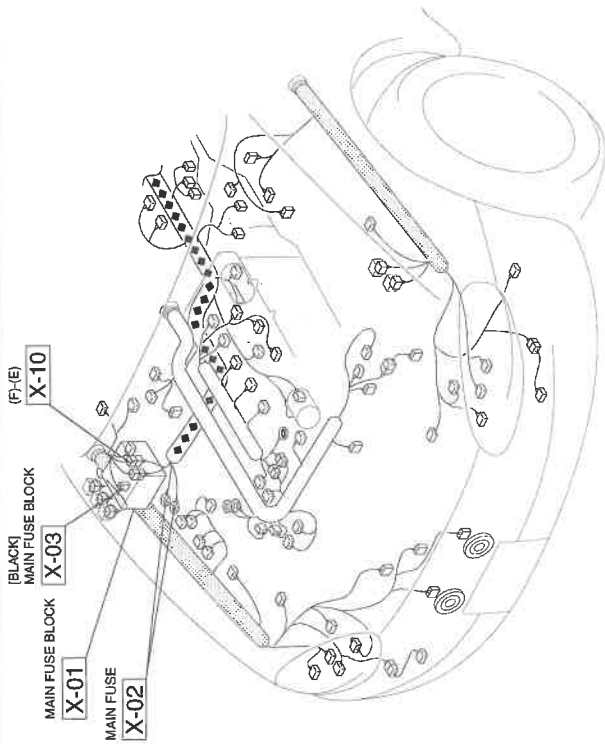

AUDIO SYSTEM (STANDARD AUDIO)

J-1

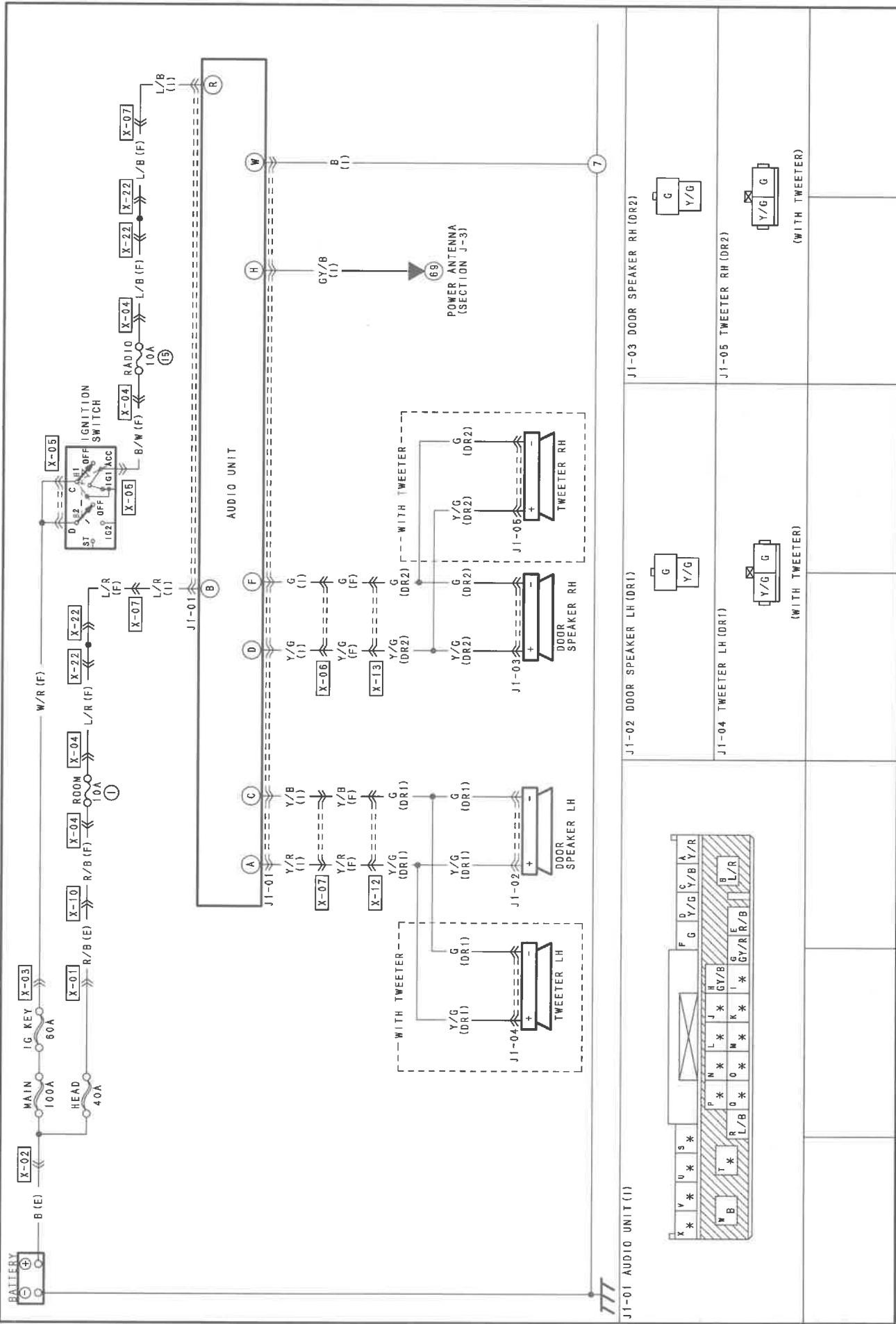

HARNESS SYMBOL : (F) (E) (R)

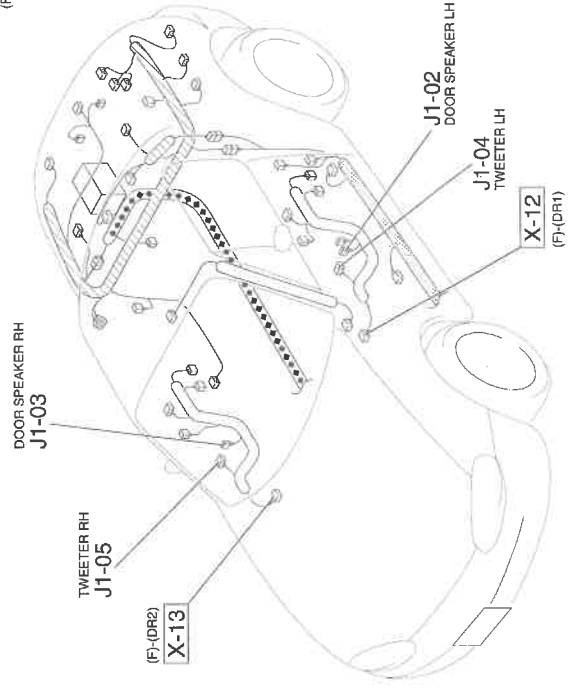
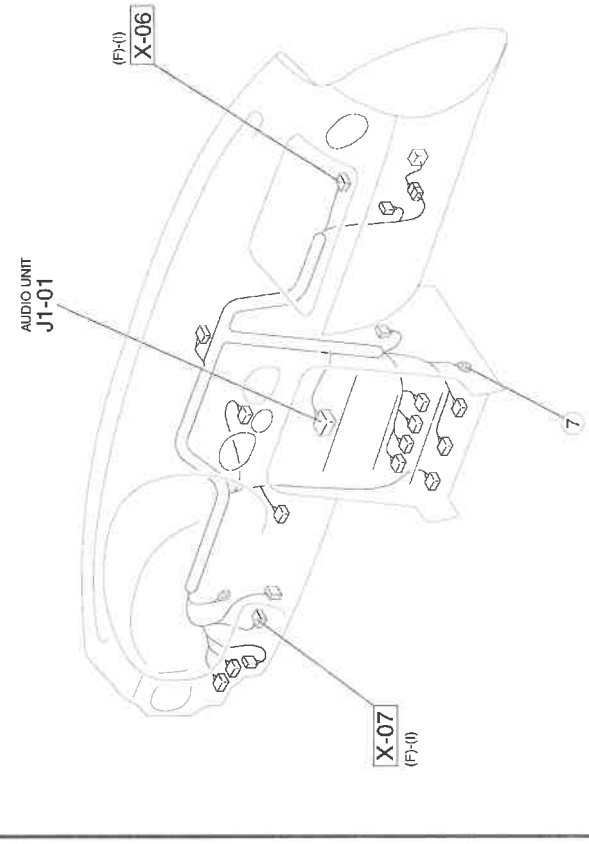
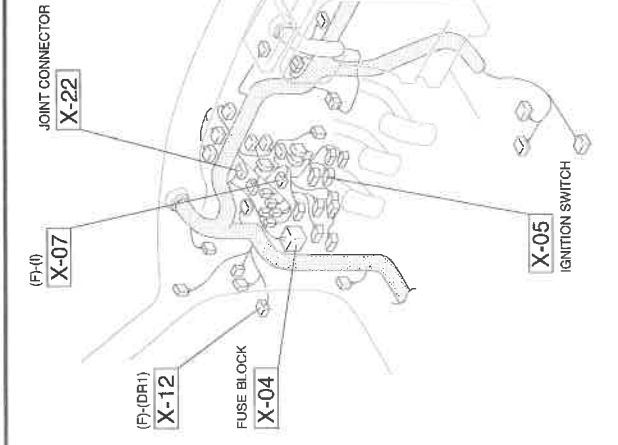
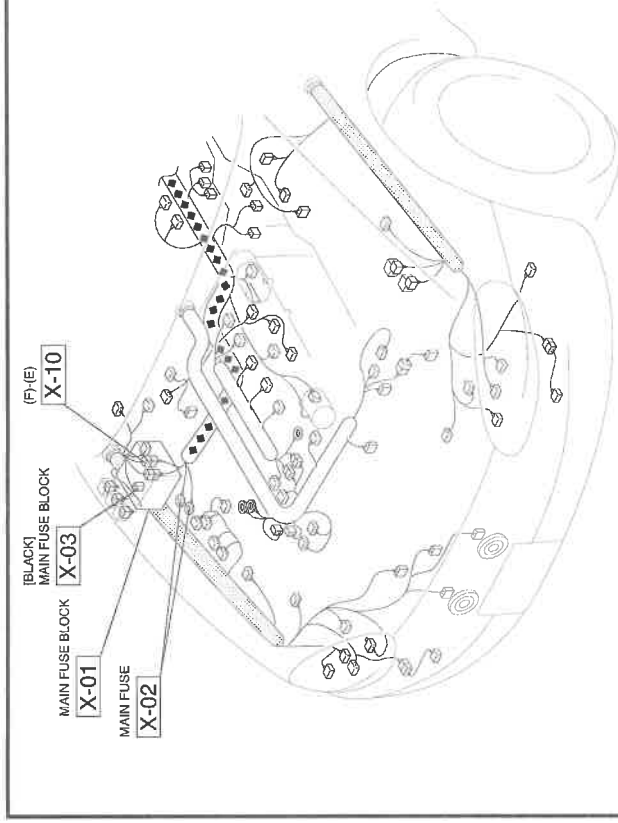

AUDIO SYSTEM (BOSE AUDIO)

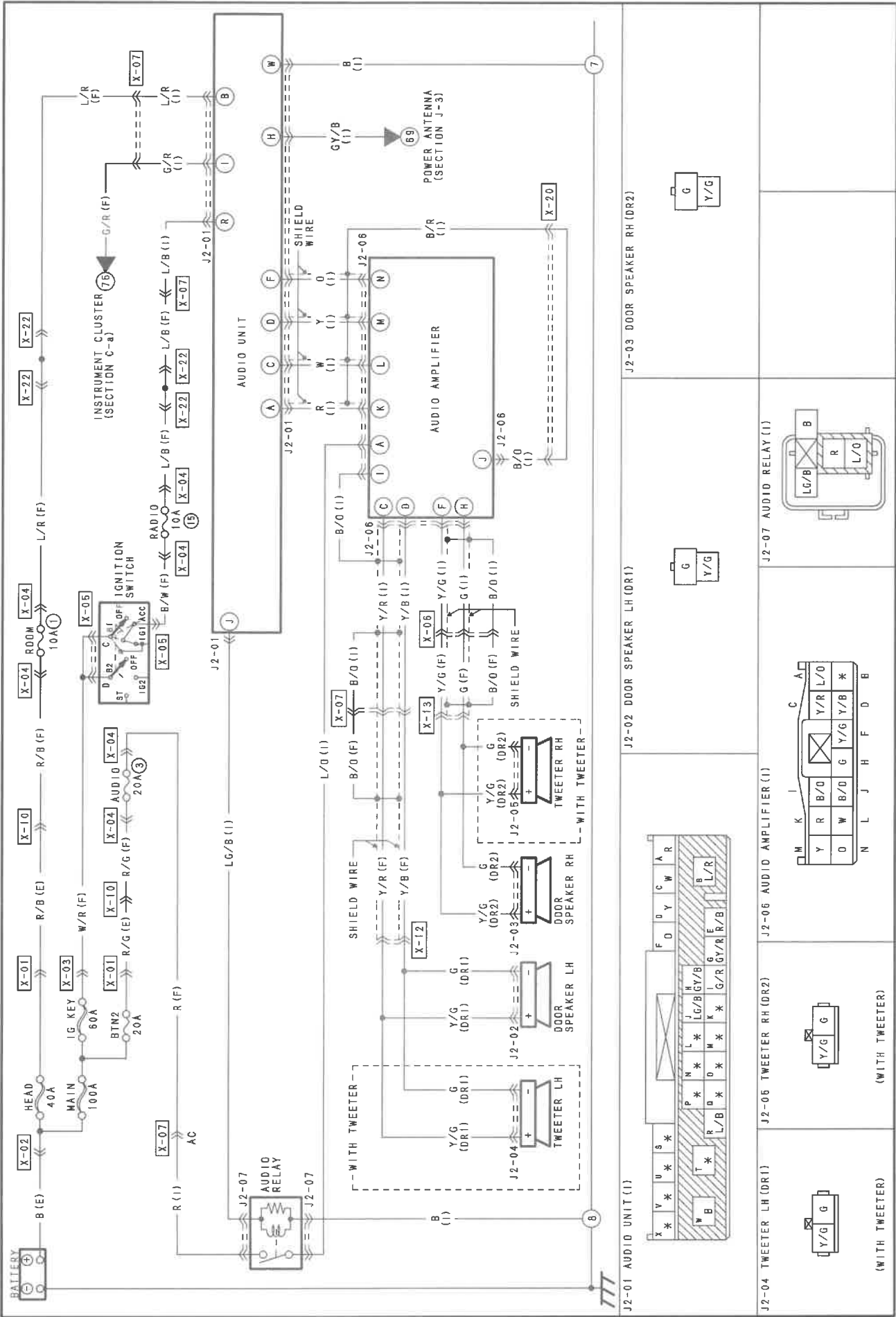

HARNES SYMBOL: (F) (E) (R)

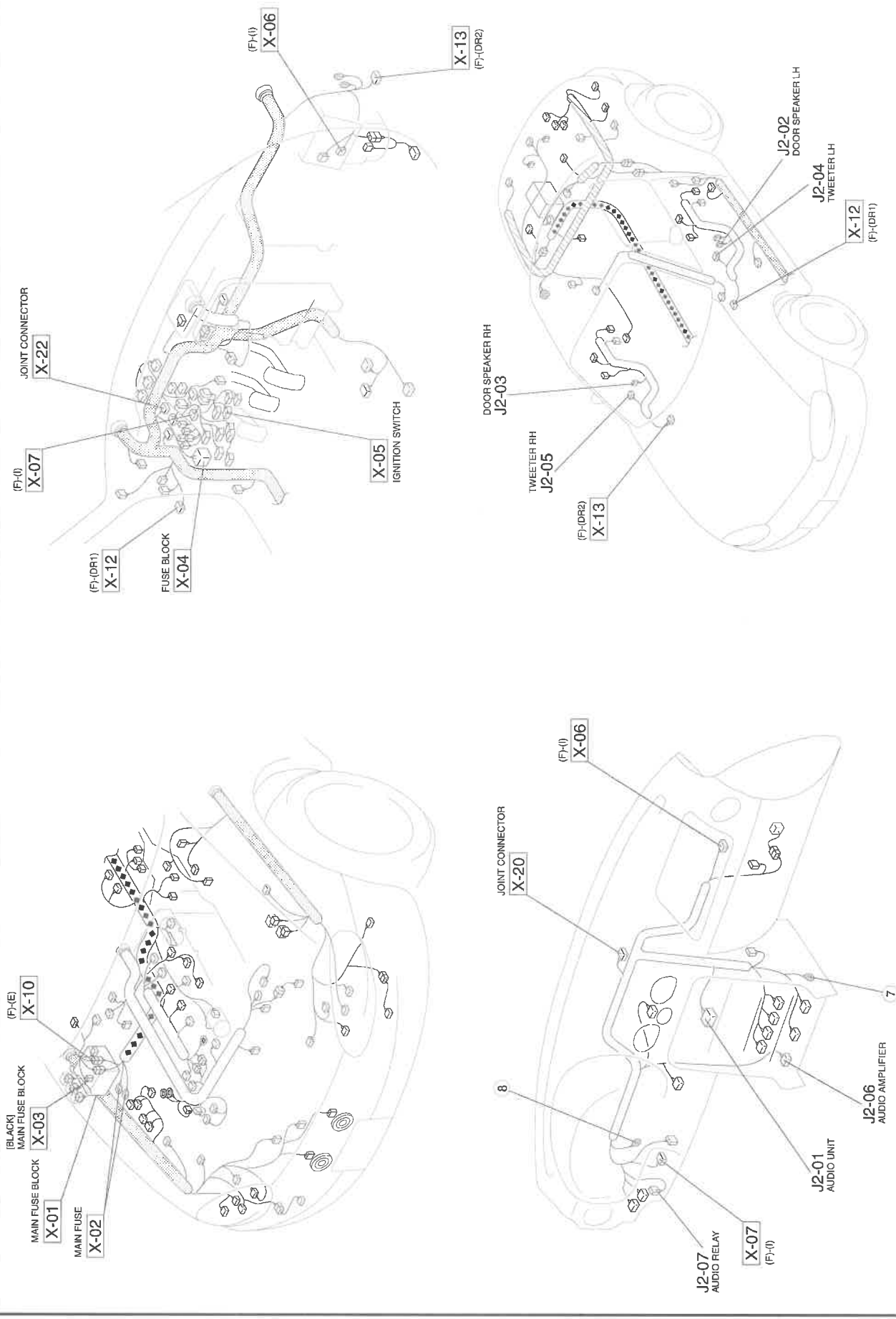

POWER ANTENNA

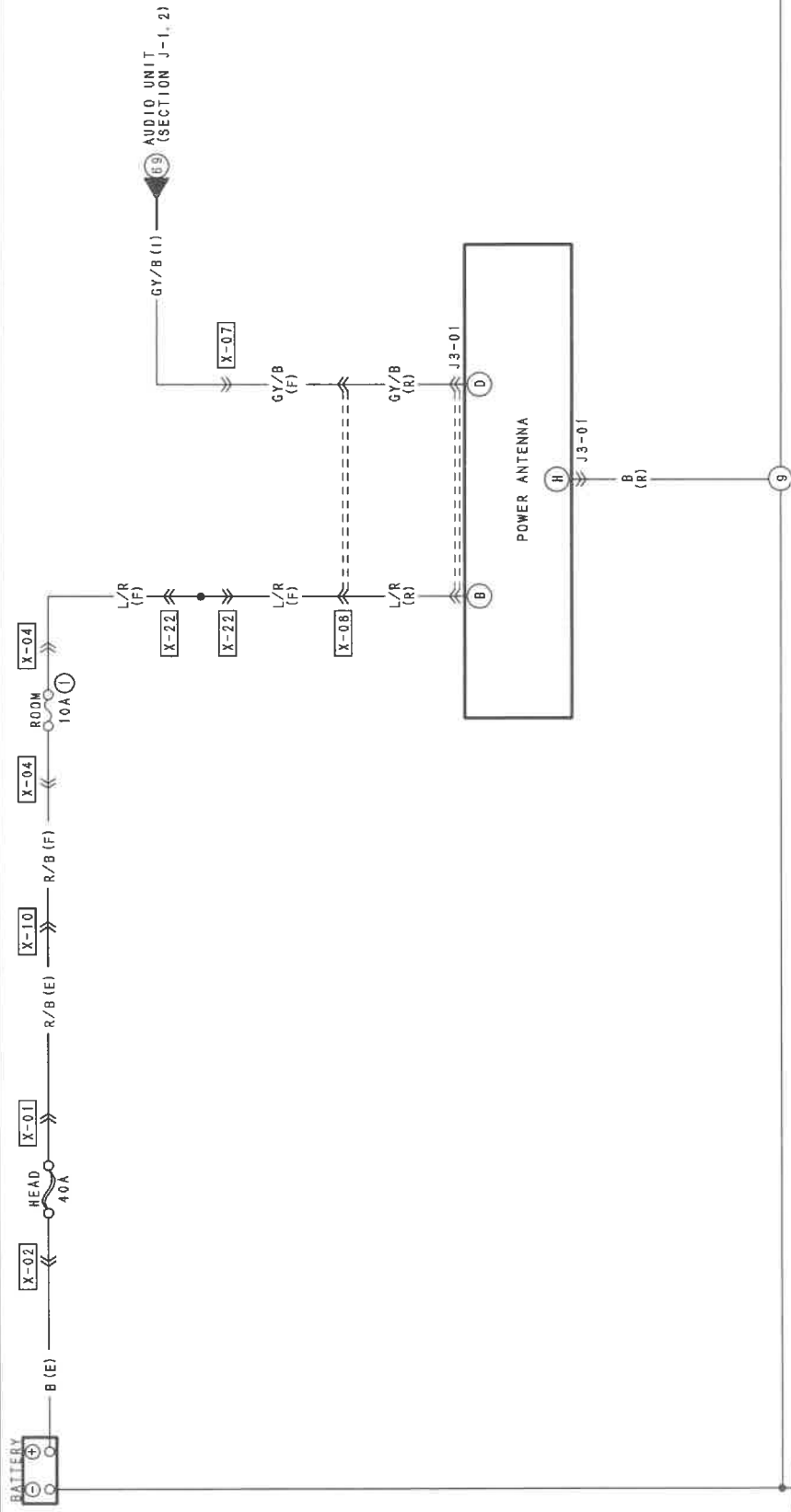

J3-01 POWER ANTENNA (R)

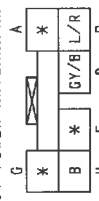

HARNESS SYMBOL :  (F)  (E)  (R)

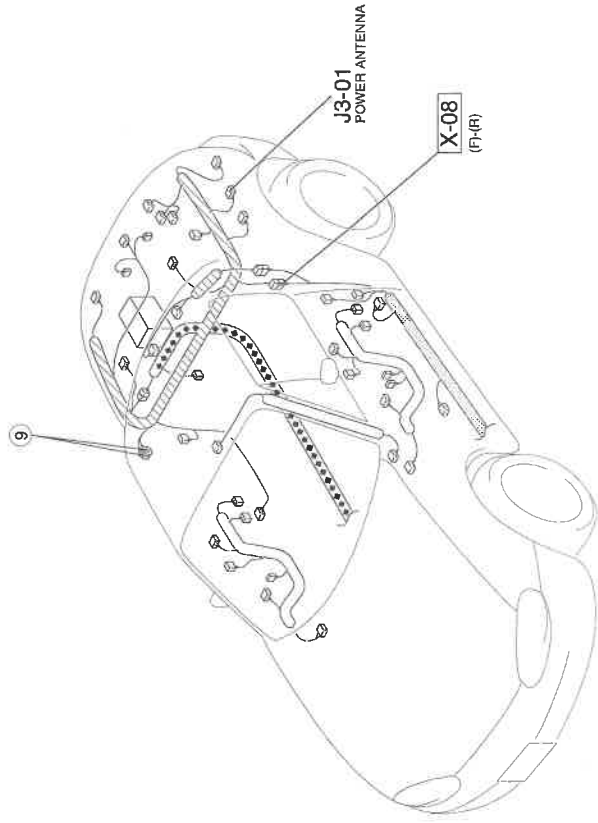
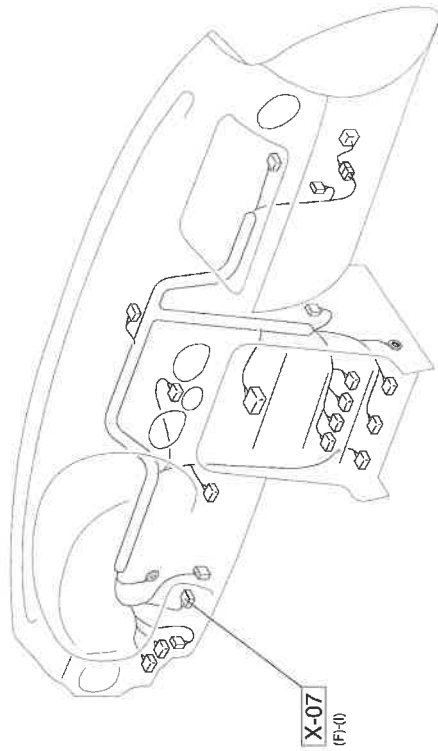
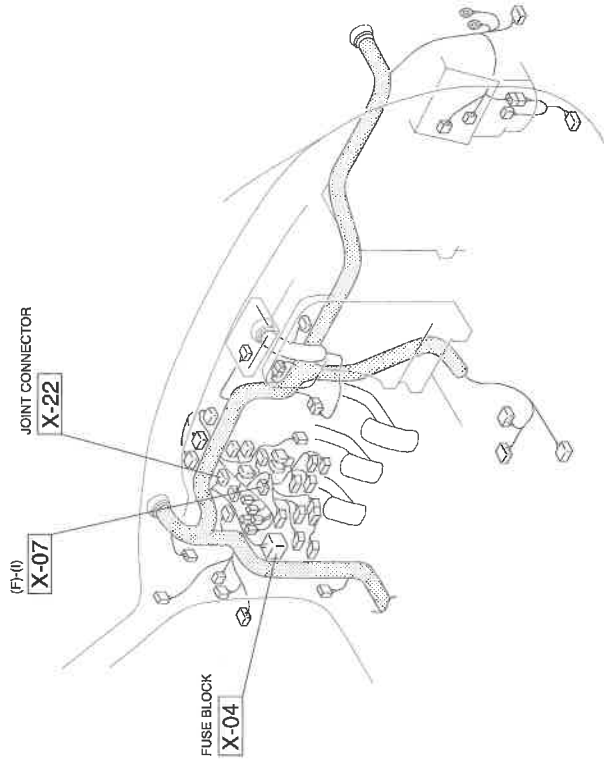
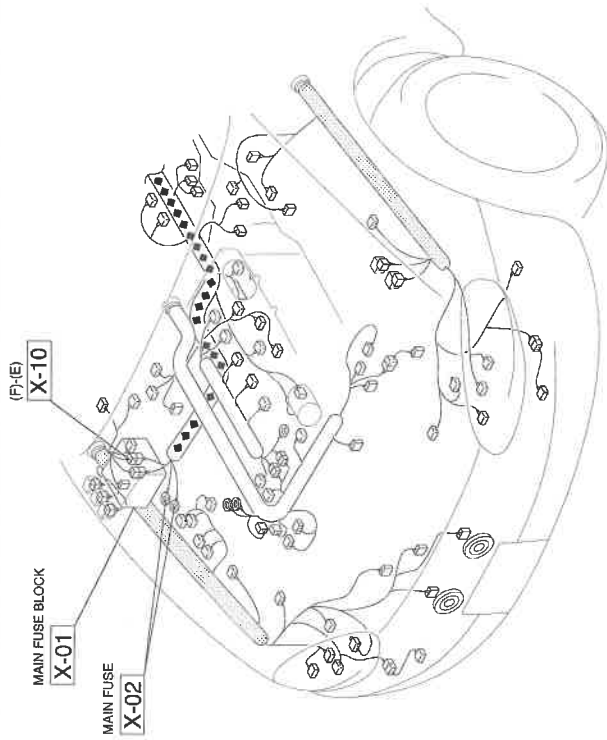

POWER WINDOW SYSTEM

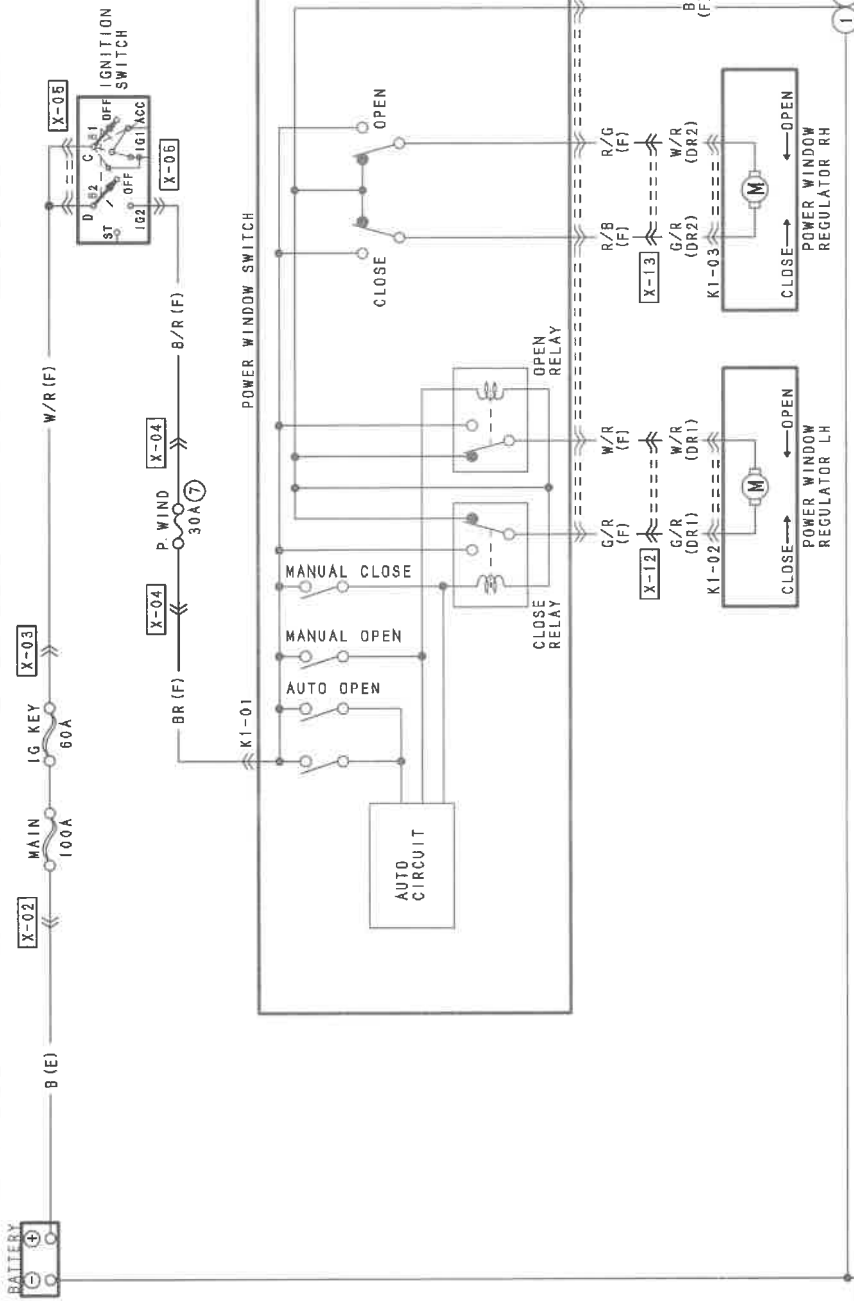

K1-01 POWER WINDOW SWITCH (F)	R/G R/B B BR W/R G/R	K1-02 POWER WINDOW REGULATOR LH (DR1)	G/R W/R	
		K1-03 POWER WINDOW REGULATOR RH (DR2)	G/R W/R	

HARNES SYMBOL : (F) (E) (R)

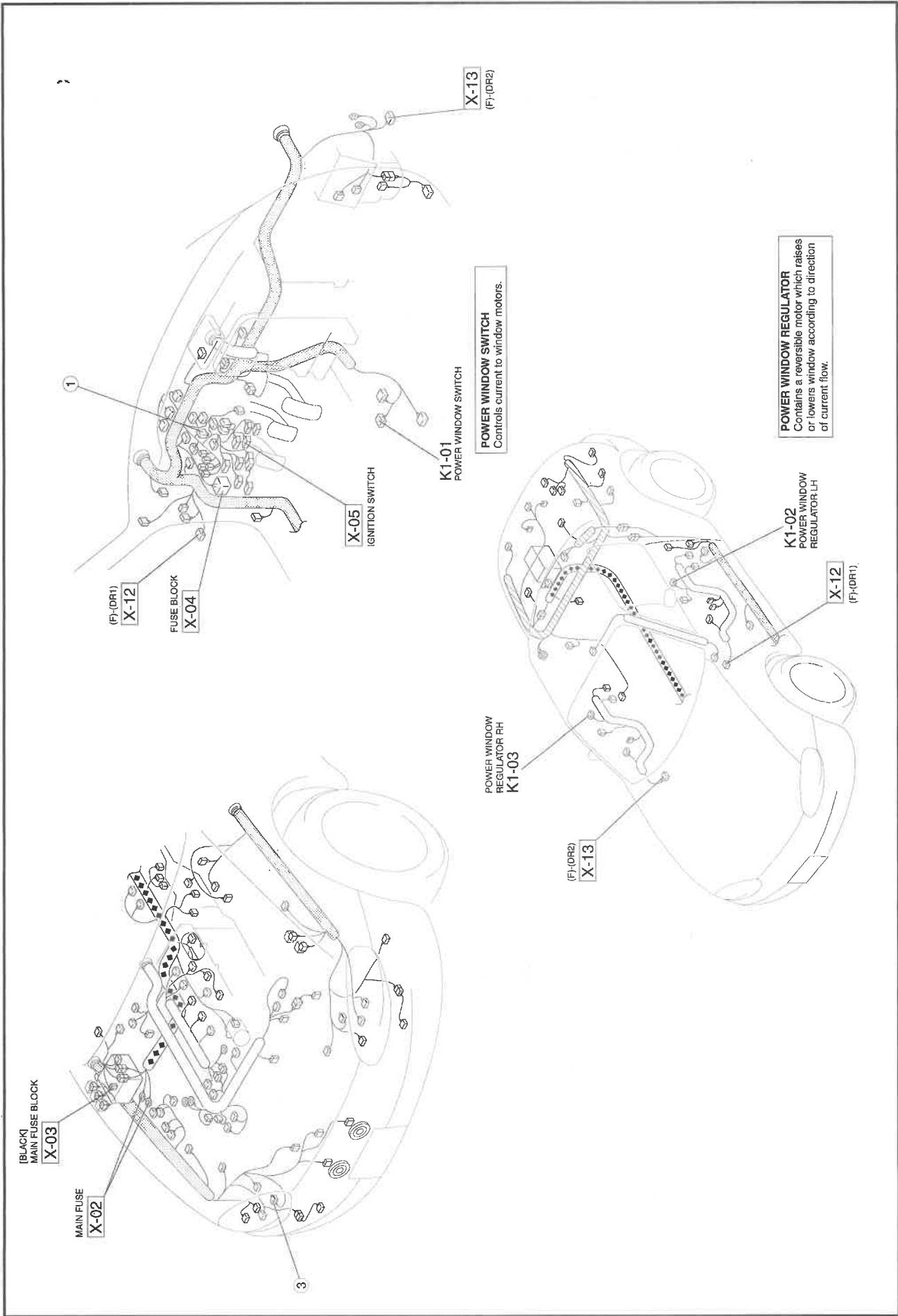

POWER DOOR LOCK SYSTEM

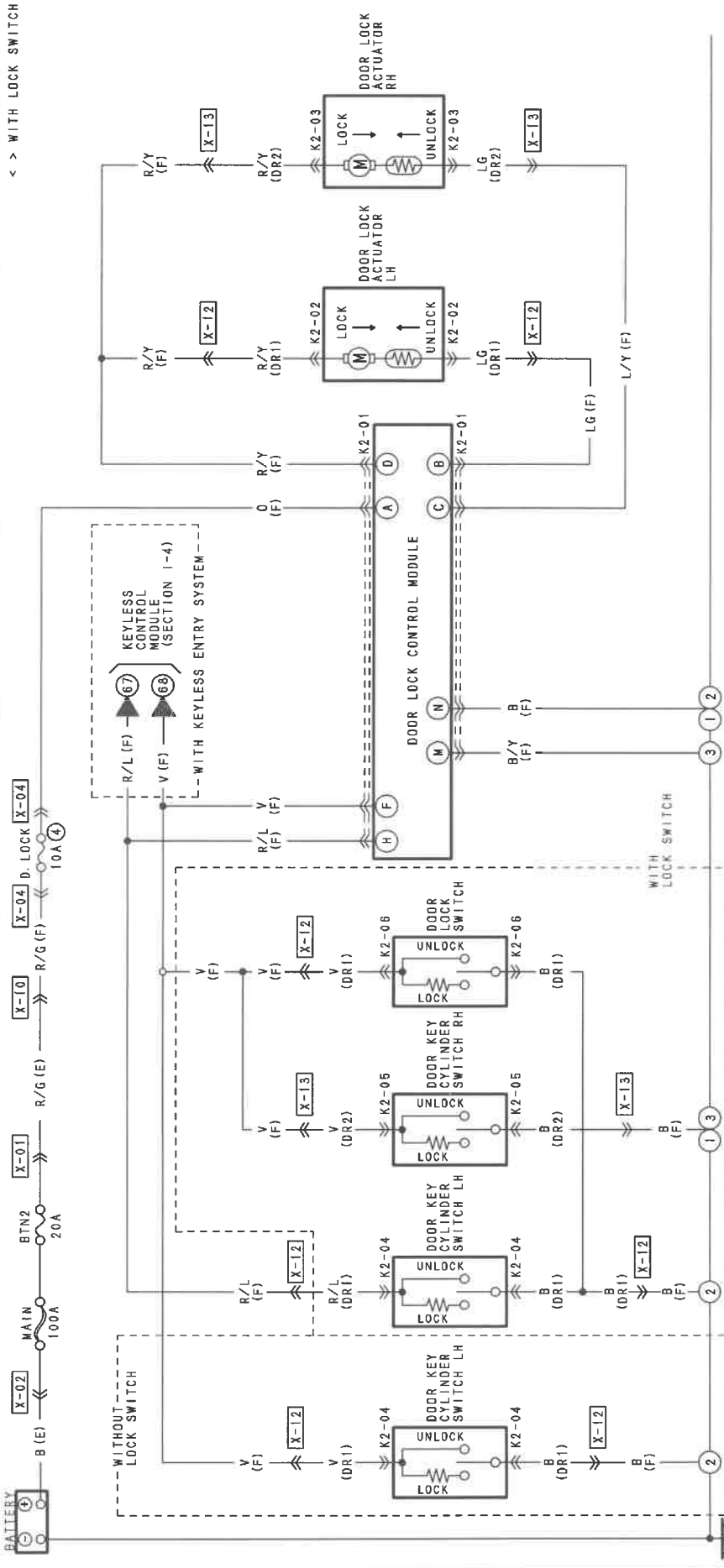

K2-01 DOOR LOCK CONTROL MODULE (F)	K2-02 DOOR LOCK ACTUATOR LH (DR1)	K2-03 DOOR LOCK ACTUATOR RH (DR2)	K2-04 DOOR KEY CYLINDER SWITCH LH (DR1)	K2-05 DOOR KEY CYLINDER SWITCH RH (DR2)	K2-06 DOOR LOCK SWITCH (DR1)																									
<table border="1"> <tr><td>M</td><td>K</td><td>I</td><td>C</td><td>A</td></tr> <tr><td>B/Y</td><td>*</td><td>*</td><td>L/Y</td><td>O</td></tr> <tr><td>B</td><td>*</td><td>*</td><td>R/L</td><td>V</td></tr> <tr><td>N</td><td>L</td><td>J</td><td>H</td><td>F</td></tr> <tr><td></td><td></td><td></td><td>D</td><td>B</td></tr> </table>	M	K	I	C	A	B/Y	*	*	L/Y	O	B	*	*	R/L	V	N	L	J	H	F				D	B					
M	K	I	C	A																										
B/Y	*	*	L/Y	O																										
B	*	*	R/L	V																										
N	L	J	H	F																										
			D	B																										
					(WITH LOCK SWITCH)																									
					(WITH LOCK SWITCH)																									

HARNES SYMBOL : [Symbol] (F) [Symbol] (E) [Symbol] (R)

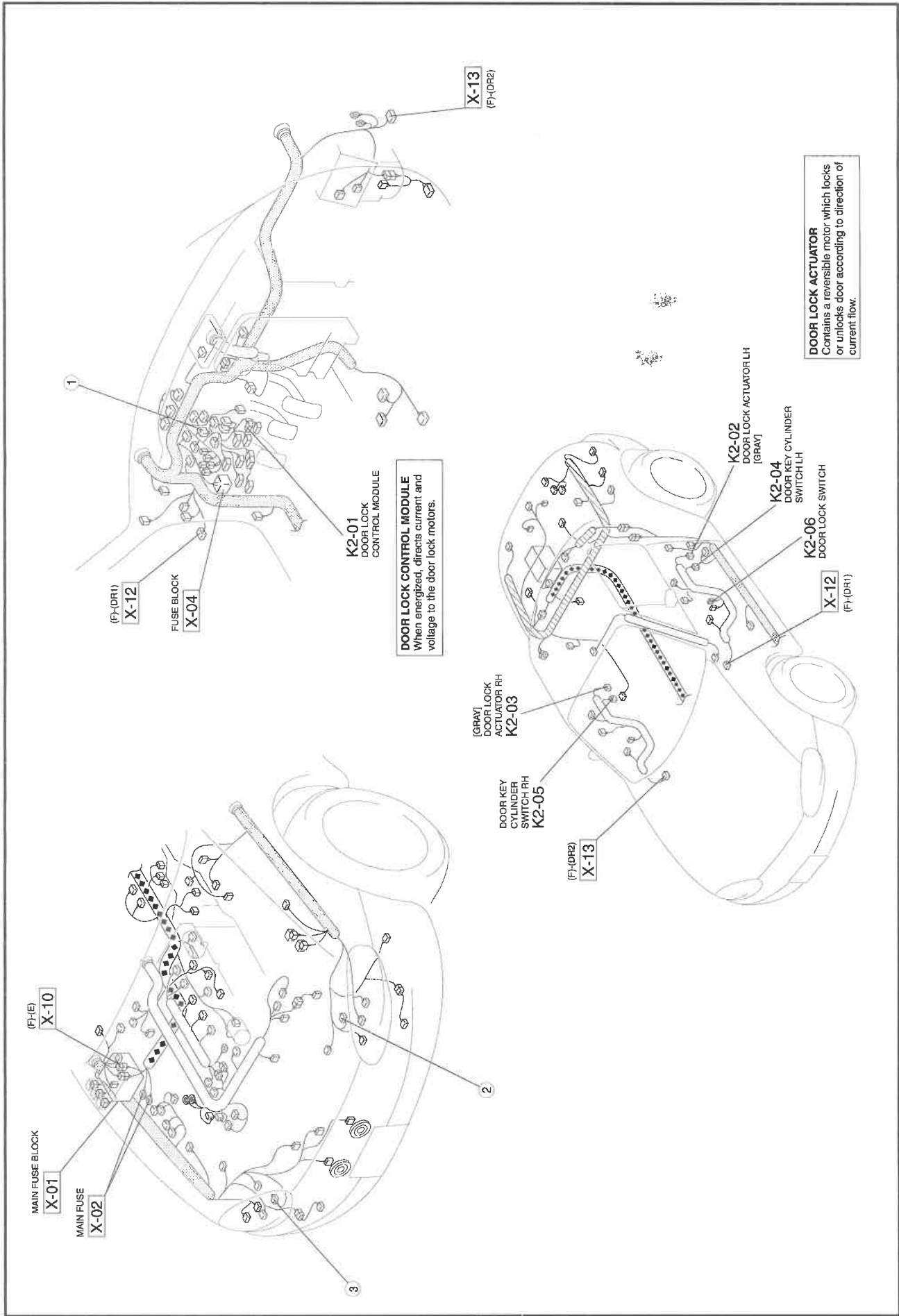

POWER OUTSIDE MIRROR

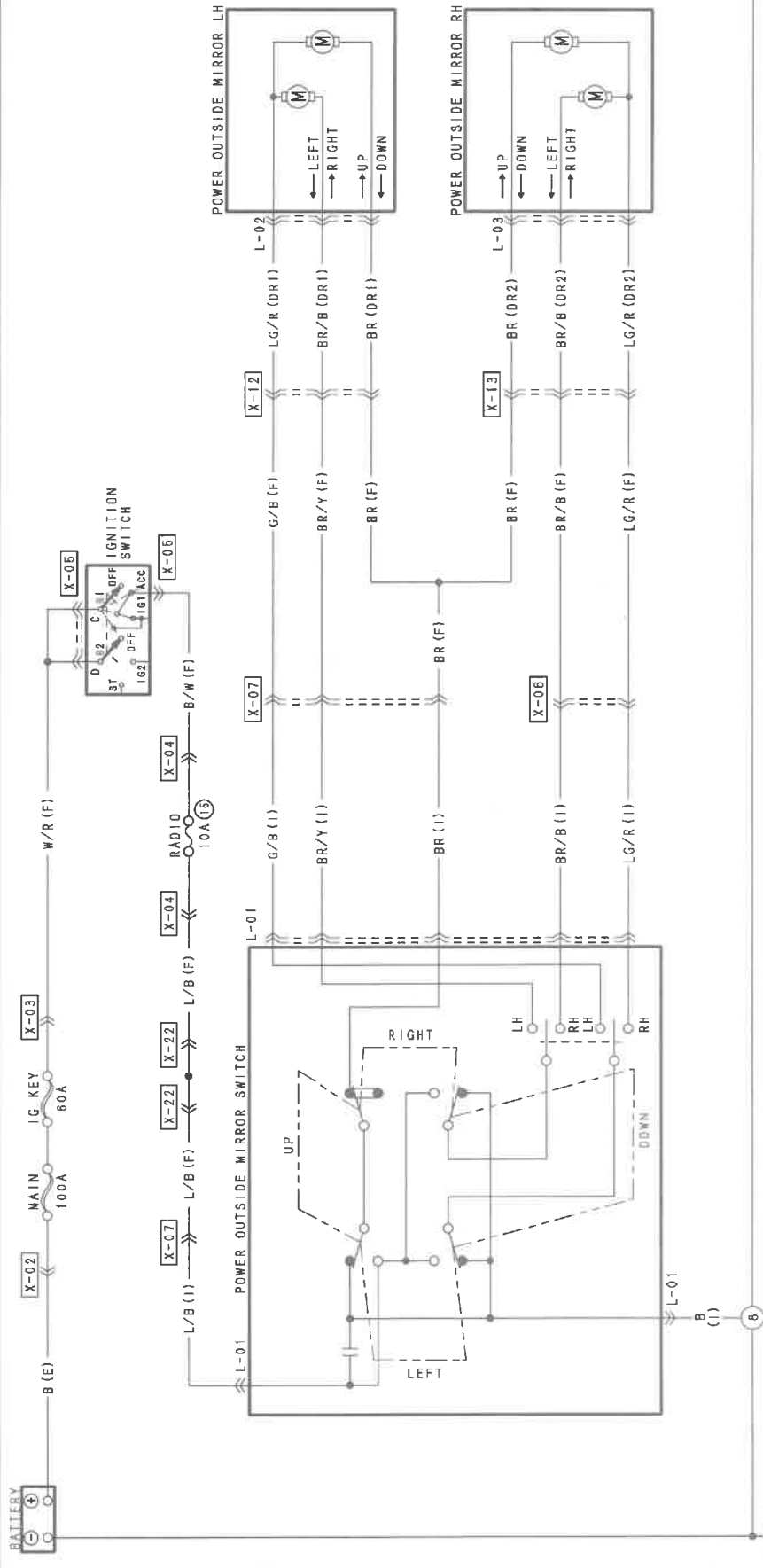

L-01 POWER OUTSIDE MIRROR SWITCH (1)

L-02 POWER OUTSIDE MIRROR LH (DR1)

L-03 POWER OUTSIDE MIRROR RH (DR2)

L/B	LG/R	G/B
B	BR	BR/B/BR/Y

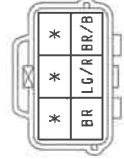
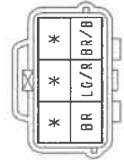

HARNES SYMBOL : (F) (E) (R)

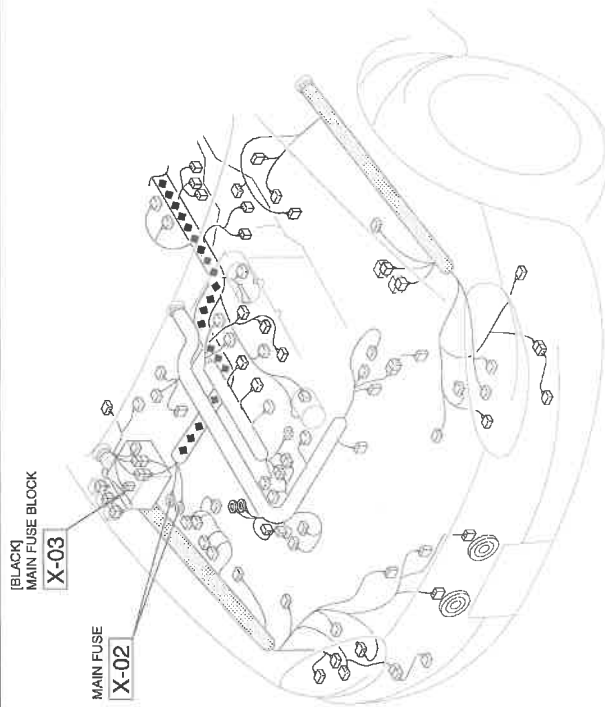

[BLACK]
MAIN FUSE BLOCK
X-03

MAIN FUSE
X-02

(F)(I)
X-07

JOINT CONNECTOR
X-22

(F)(DR1)
X-12

FUSE BLOCK
X-04

X-05
IGNITION SWITCH

(F)(I)
X-06

POWER OUTSIDE MIRROR
Contains reversible motors which move the mirror up, down, left, and right.

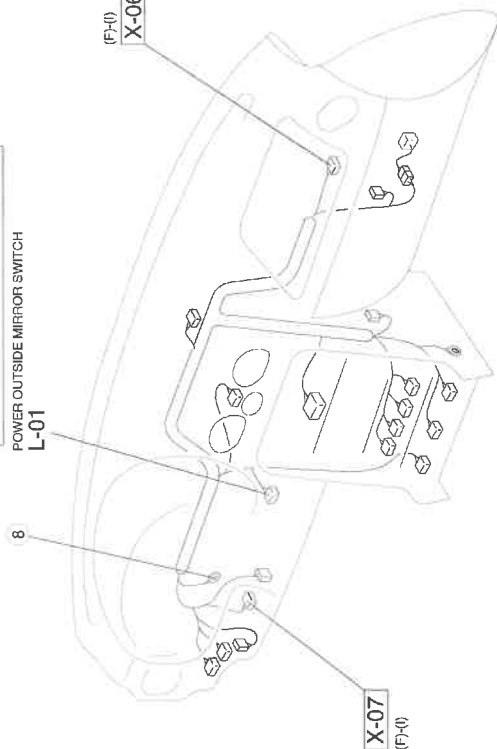

POWER OUTSIDE MIRROR SWITCH
Controls current to power outside mirrors.

L-01
POWER OUTSIDE MIRROR SWITCH

X-07
(F)(I)

(F)(I)
X-06

(GRAY)
POWER OUTSIDE MIRROR RH
L-03

(F)(DR2)
X-13

L-02
POWER OUTSIDE MIRROR LH
(GRAY)

X-12
(F)(DR1)

ANTILOCK BRAKE SYSTEM

O

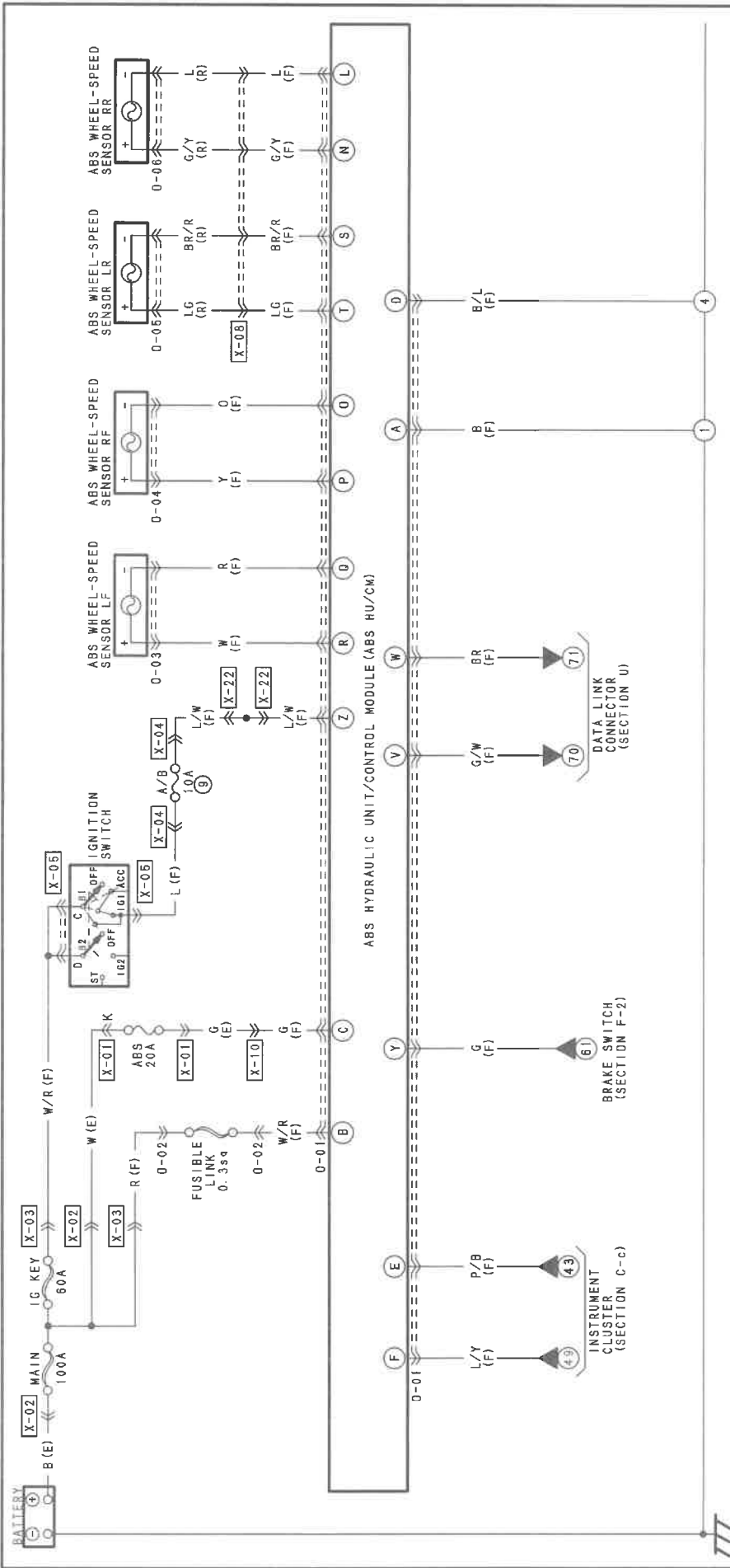

0-01 ABS HU/CM (F)	0-02 FUSIBLE LINK (F)	0-03 ABS WHEEL-SPEED SENSOR L F (F)	0-04 ABS WHEEL-SPEED SENSOR R F (F)	0-05 ABS WHEEL-SPEED SENSOR L R (R)

HARNESS SYMBOL : (F) (E) (R)

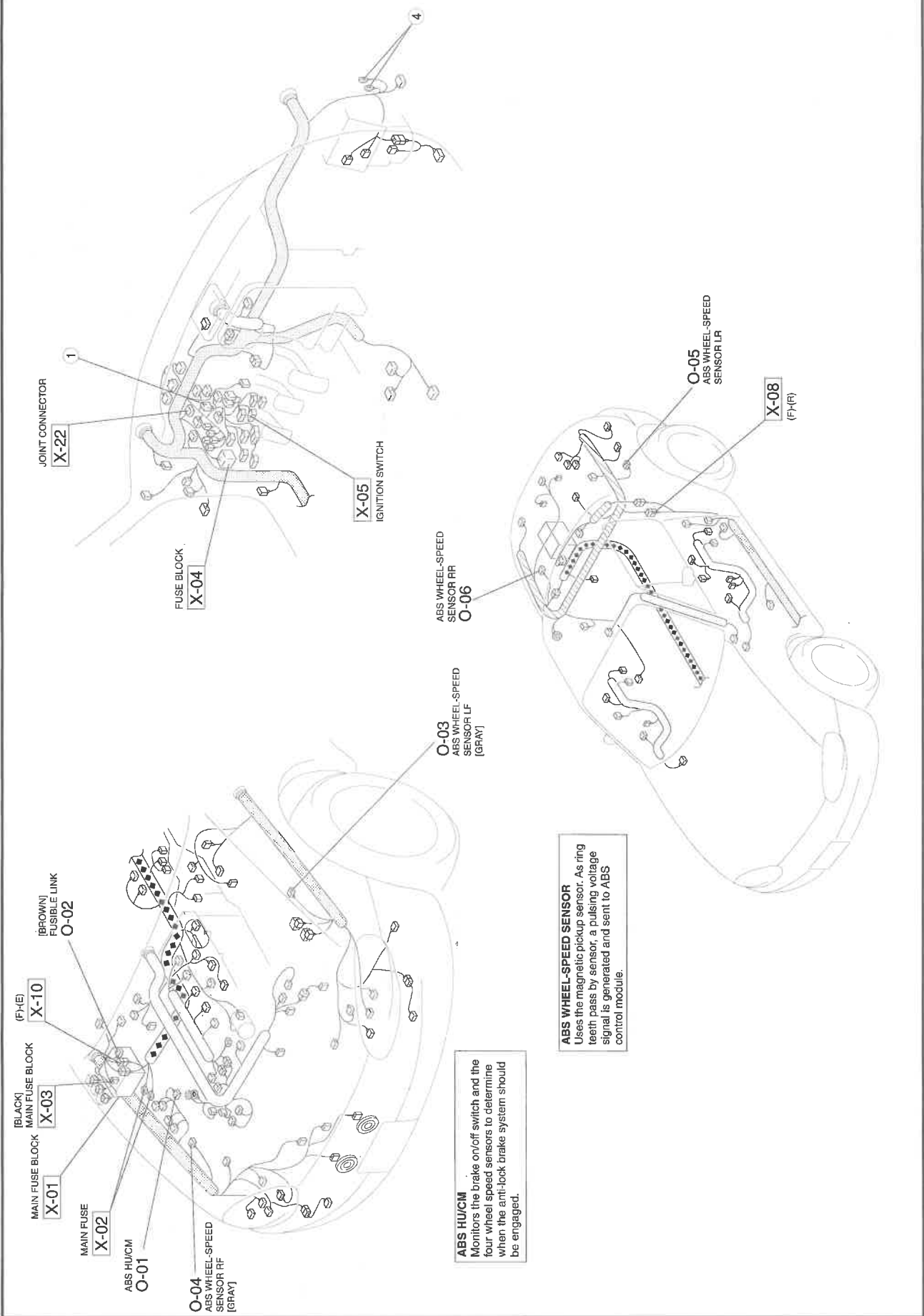

Q

CRUISE CONTROL SYSTEM

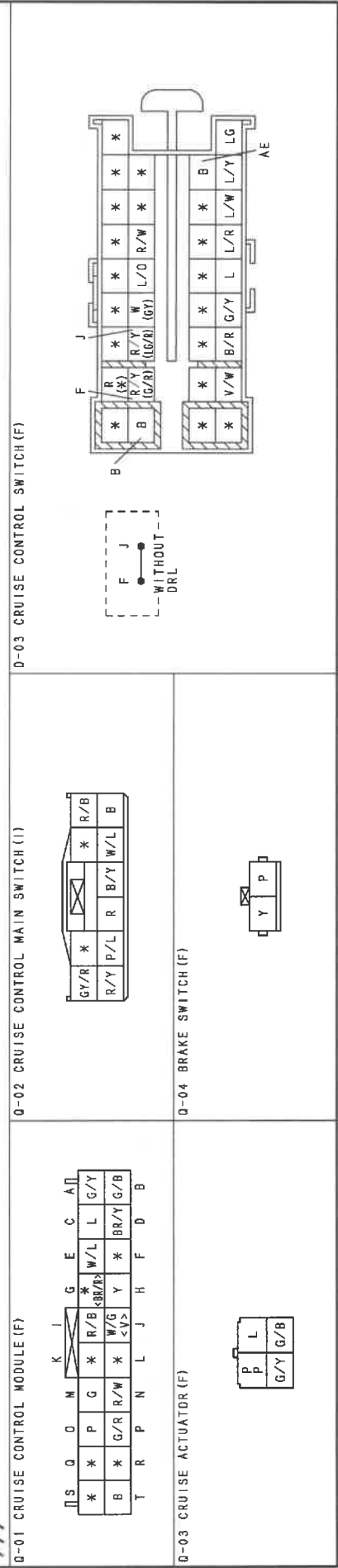
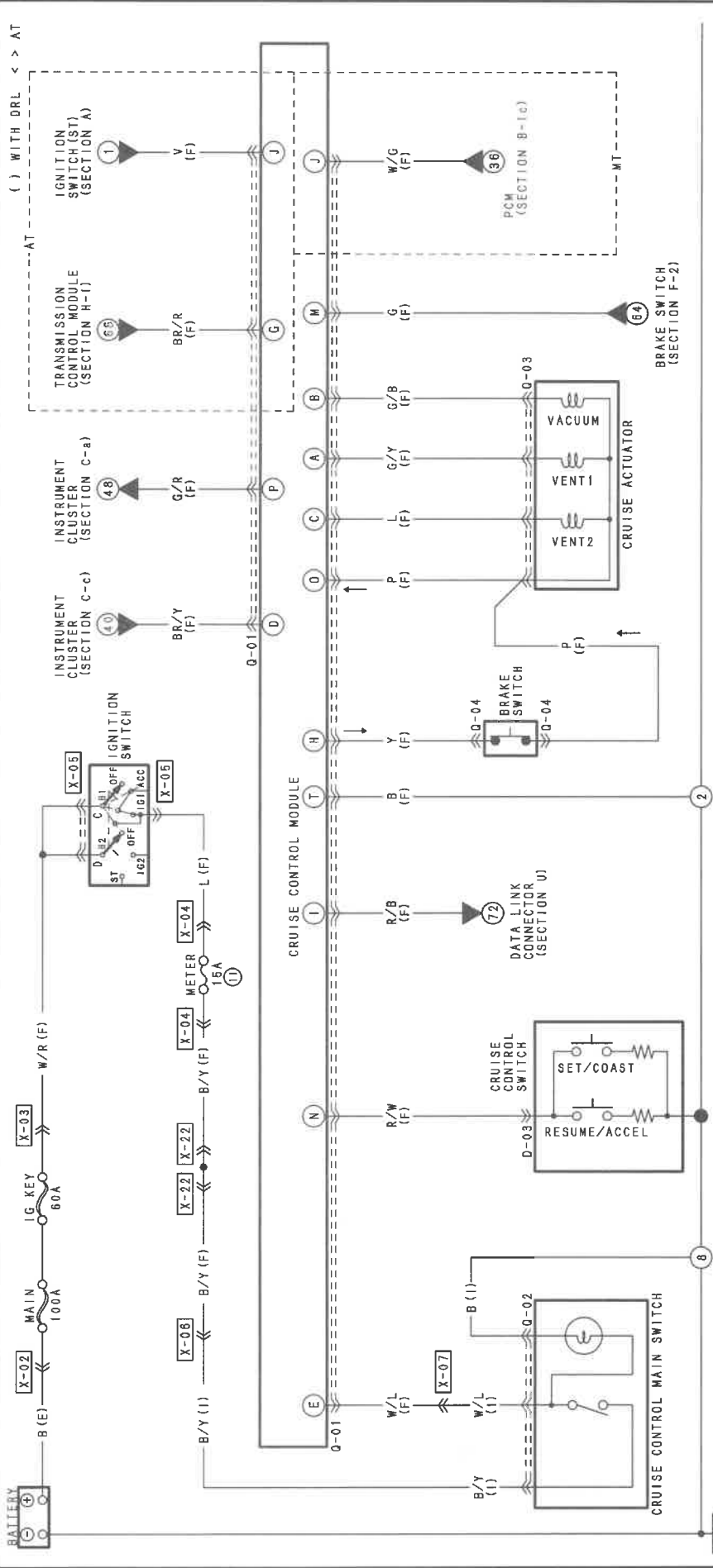

HARNES SYMBOL : (F) (E) (R)

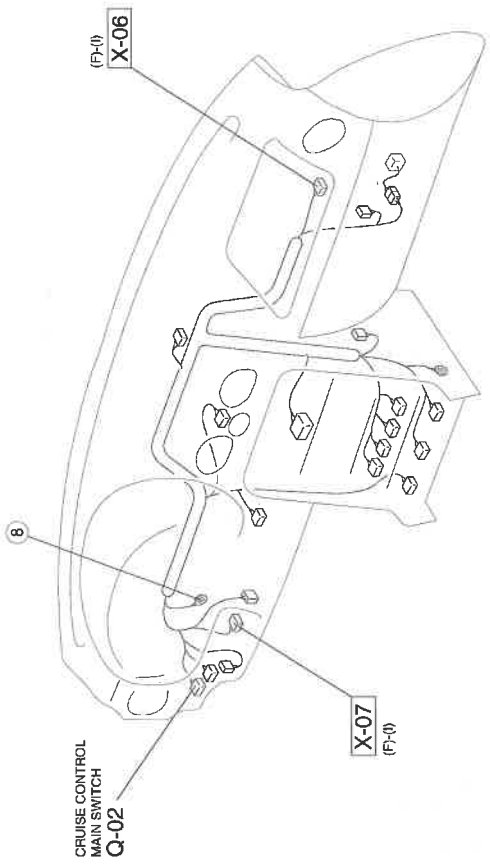
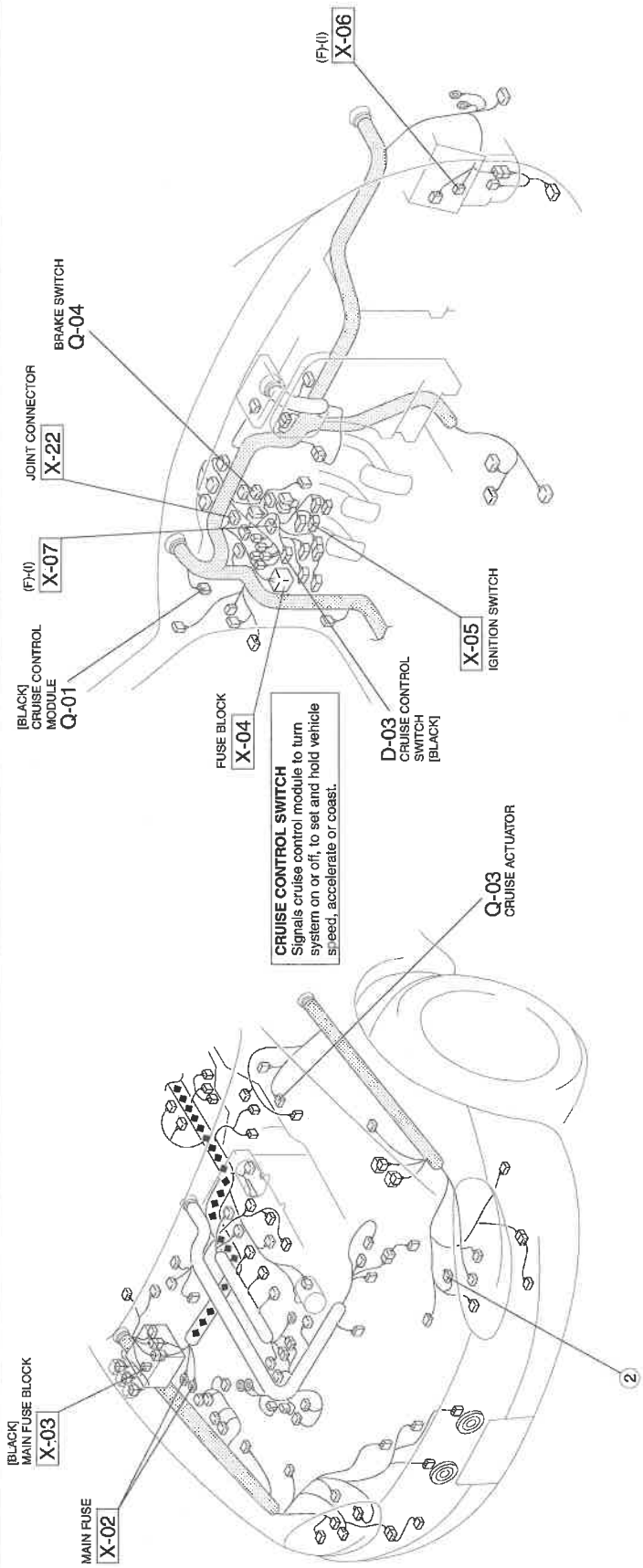

AIR BAG SYSTEM

AIR BAG SYSTEM SERVICE WARNINGS

A5U081001046W02

Component Disassembly

- Disassembling and reassembling the components of the air bag system can render the system inoperative, which may result in serious injury or death in the event of an accident. Do not disassemble any air bag system component.

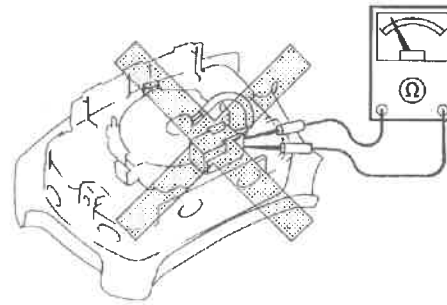

Z5U0810W001

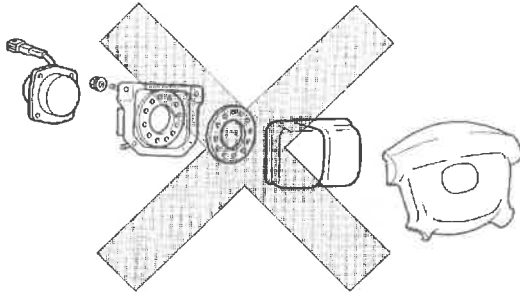

YMUB10WA1

Air Bag Module Handling

- A live (undeployed) air bag module may accidentally deploy when it is handled and cause serious injury. When carrying a live (undeployed) air bag module, point the front surface away from your body to lessen the chance of injury in case it deploys.

Wiring Harness Repair

- Incorrectly repairing an air bag system wiring harness can accidentally deploy the air bag module or pre-tensioner seat belt, which can cause serious injury. If a problem is found in the system wiring, replace the wiring harness. Do not try to repair it.

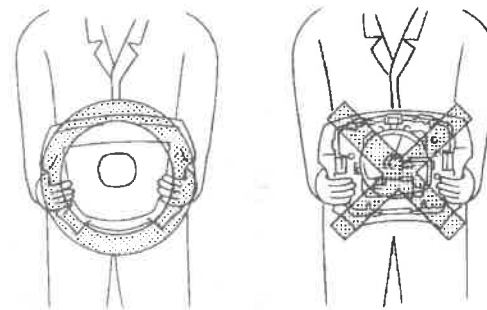

Y5J8130W002

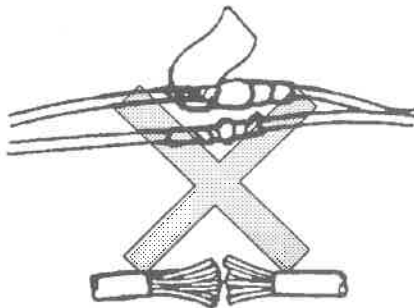

YDE81301201

- A live (undeployed) air bag module placed face down on a surface is dangerous. If the air bag module deploys, the motion of the module can cause serious injury. Always face the front surface up to reduce the motion of the module in case it accidentally deploys.

Air Bag Module Inspection

- Inspecting an air bag module using an ohmmeter can deploy the air bag module, which may cause serious injury. Do not use an ohmmeter to inspect an air bag module. Always use the on-board diagnostic function to diagnose the air bag module for malfunctions. (See (0802) FOREWORD.)

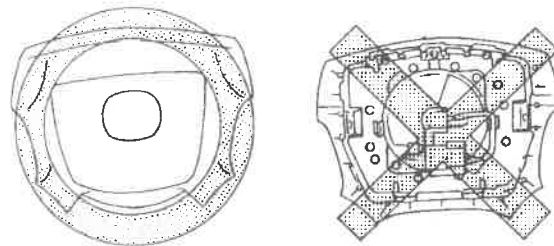

Y5J8130W003

SAS Control Module Handling

- Disconnecting the SAS control module connector or removing the SAS control module with the ignition switch at ON position can cause the air bag modules and

The references in this section can be found in Workshop Manual [1752-1-02J(2002-10)]

- pre-tensioner seat belts to deploy, which may seriously injure you. Before disconnecting the SAS control module connector or removing the SAS control module, turn the ignition switch to LOCK position, then disconnect the negative battery cable and wait for more than 1 minute to allow the backup power supply of the SAS control module to deplete its stored power.
- Connecting the SAS control module connector without firmly installing the SAS control module to the vehicle is dangerous. The crash sensor inside the control module may send an electrical signal to the air bag modules and pre-tensioner seat belts. This will deploy the air bag modules and pre-tensioner seat belts, which may result in serious injury. Therefore, before connecting the connector, firmly mount the control module to the vehicle.
- For vehicles with a single point sensor, once an air bag module is deployed due to an accident or other causes, the SAS control module must be replaced with a new one even if the used one does not have any external signs of damage. The used SAS control module may have been damaged internally which may cause improper operation, resulting in major injuries or even death. The used single point SAS control module cannot be bench-checked or self-educated.

Crush Zone Sensor Handling

- Disconnecting the crush zone sensor connector or removing the crush zone sensor with the ignition switch at ON position can cause the air bag modules and pre-tensioner seat belts to deploy, which may seriously injure you. Before disconnecting the crush zone sensor connector or removing the crush zone sensor, turn the ignition switch to LOCK position, then disconnect the negative battery cable and wait for more than 1 minute to allow the backup power supply of the SAS control module to deplete its stored power.
- If the crush zone sensor is subjected to shock or the sensor is disassembled, the air bag modules and pre-tensioner seat belts may operate (deploy) suddenly and cause injury, or it may fail to operate normally and cause a serious accident. Do not subject the crush zone sensor to shock or disassemble the sensor.

Pre-tensioner Seat Belt Inspection

- Inspecting a pre-tensioner seat belt using an ohmmeter can deploy the pre-tensioner seat belt, which can cause serious injury. Do not use an ohmmeter to inspect the pre-tensioner seat belt. Always use the on-board diagnostic to diagnose the pre-tensioner seat belt for malfunctions.

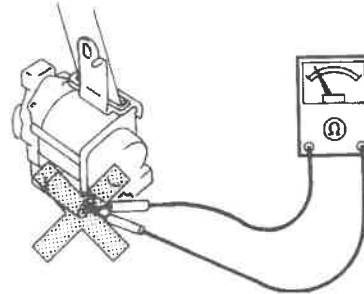

Z5U0810W002

Component Handling

- Oil, grease, water, etc. on components may cause the air bag modules and pre-tensioner seat belts to fail to deploy in an accident, which may cause serious injury. Do not allow oil, grease, water, etc., on components.
- Inserting a screwdriver, etc. into the connector of an air bag modules may damage the connector and cause the air bag module or the pre-tensioner seat belt to deploy improperly, which may cause serious injury. Do not insert any foreign objects into the connector.

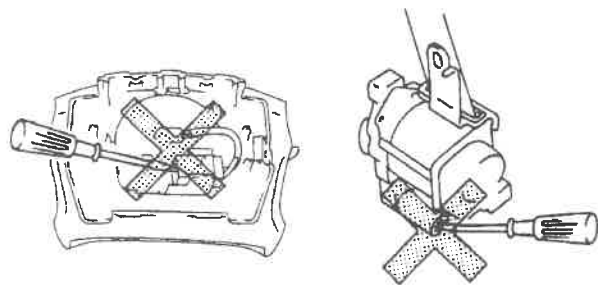

Z5U0810W003

Component Reuse

- Once an air bag module is deployed due to an accident or other causes, even if it does not have any external signs of damage, the air bag module may have been damaged internally which may cause improper operation. Improper operation may cause serious injury. Always self-check the undamaged air bag module or pre-tensioner seat belt to determine whether it can be reused. (See (0802) FOREWORD.)

The references in this section can be found in Workshop Manual [1752-1-02J(2002-10)]

AIR BAG SYSTEM

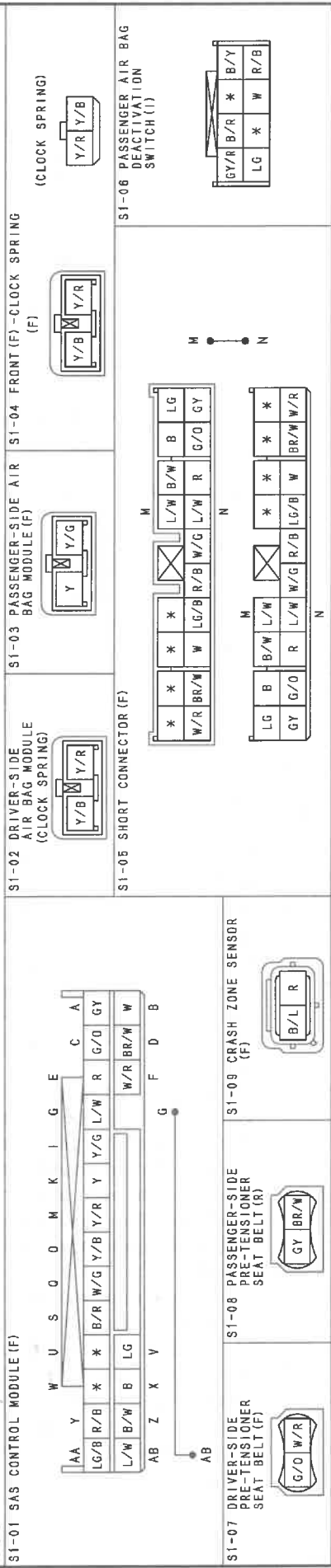
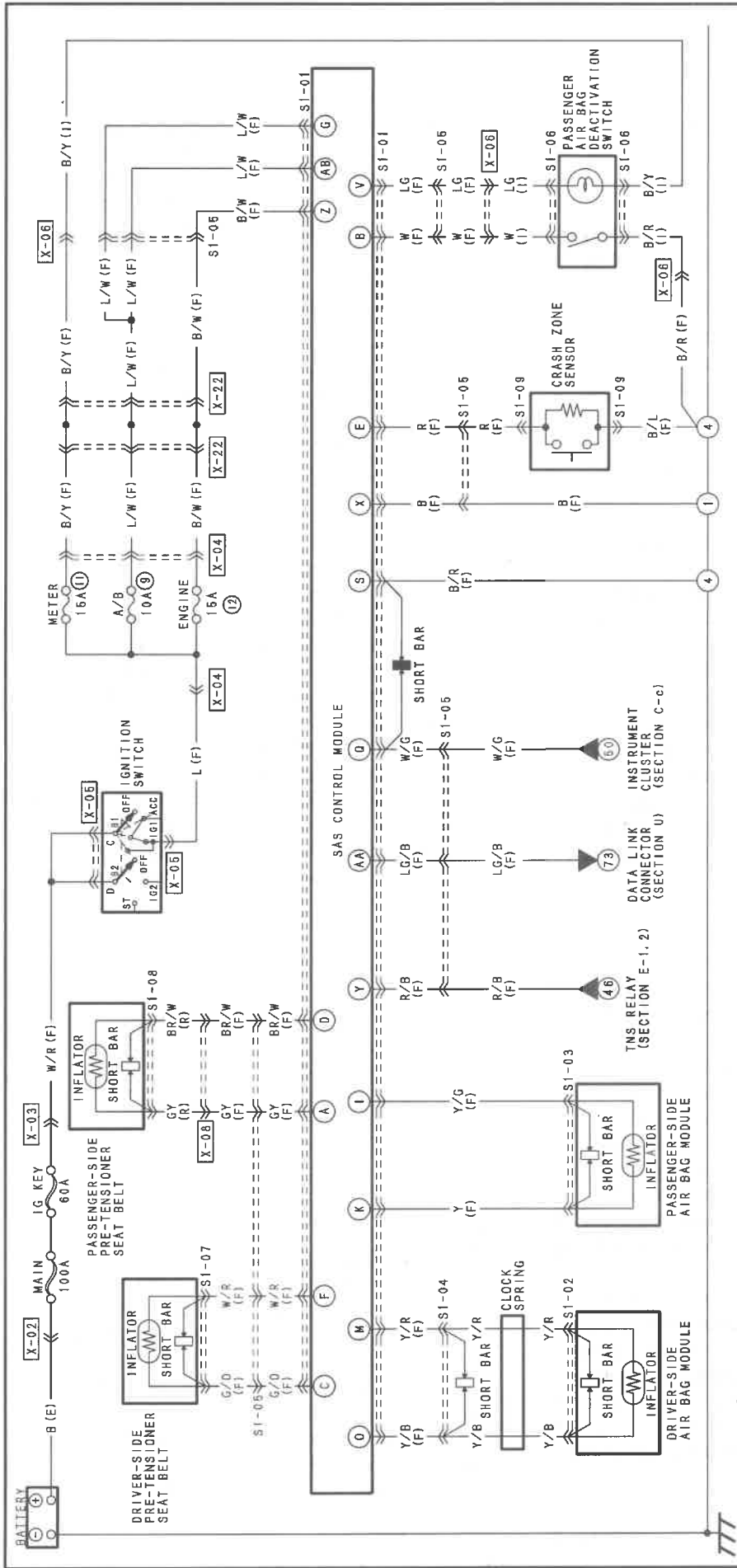

HARNES SYMBOL : (F) (E) (R)

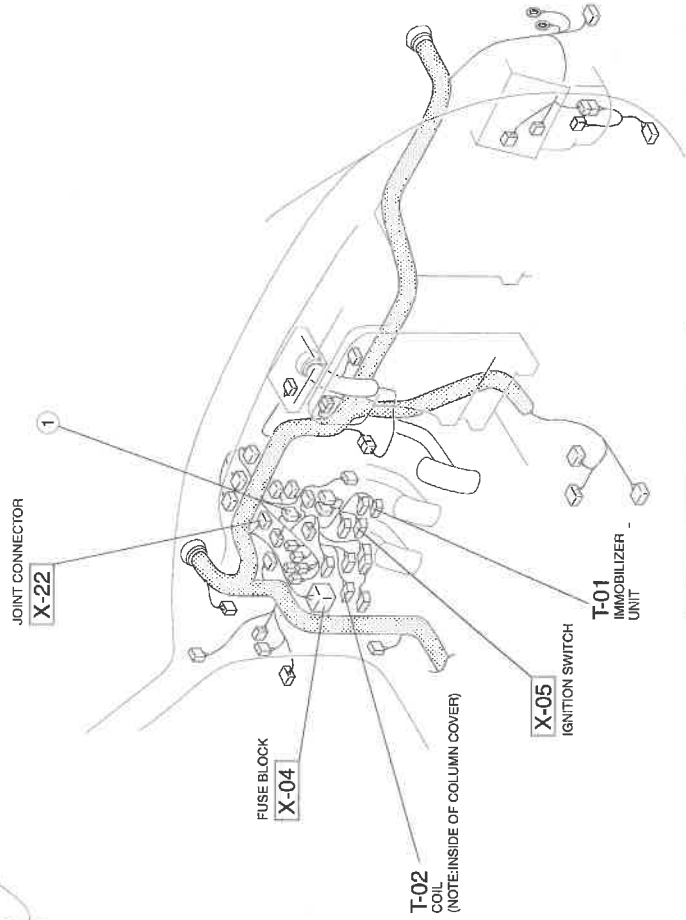
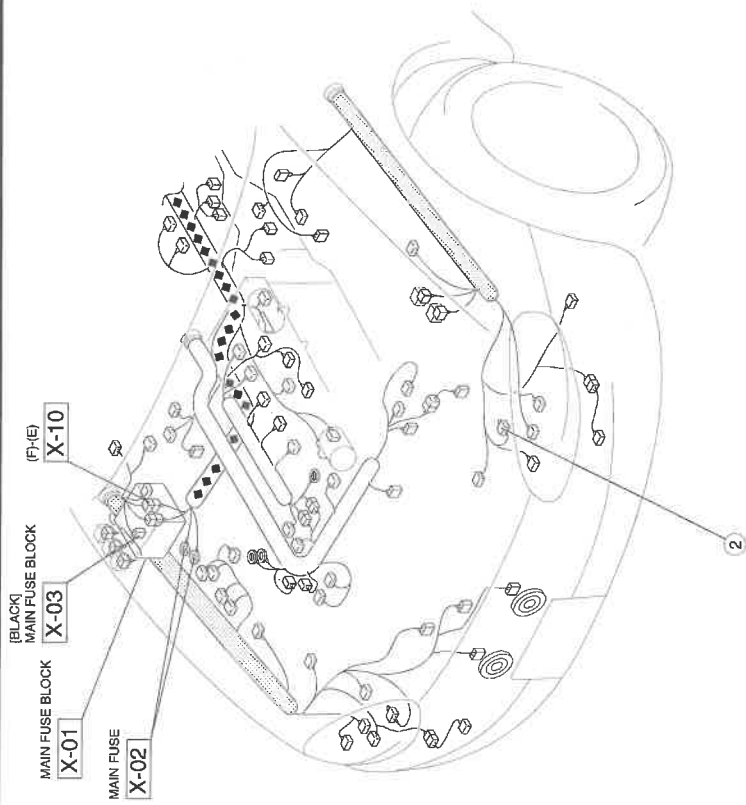

IMMOBILIZER UNIT
 The immobilizer system prevents the engine from starting even if ignition switch is short-circuited. As a result, it keeps the vehicle from stolen.

DATA LINK CONNECTOR

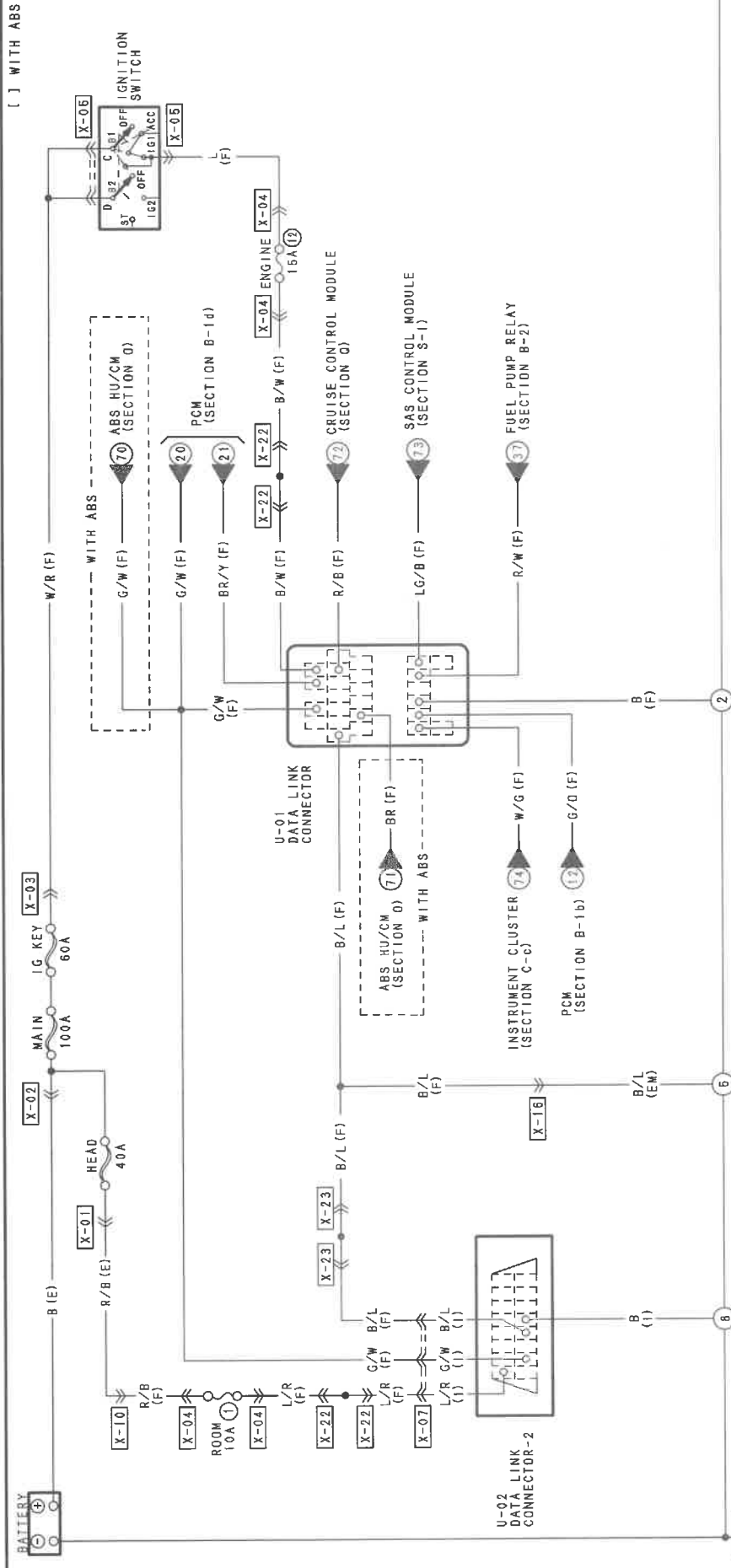

U-02 DATA LINK CONNECTOR-2 (1)

U-01 DATA LINK CONNECTOR (F)

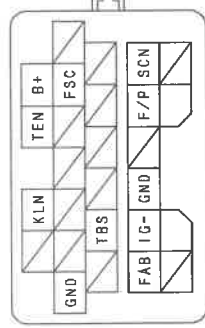
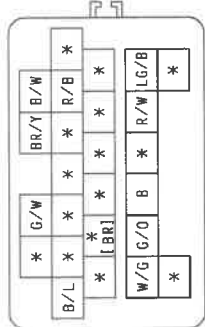

NOTE: THIS IS THE CONNECTOR AS SEEN FROM THE TERMINAL SIDE.

NOTE: THIS IS THE CONNECTOR AS SEEN FROM THE TERMINAL SIDE.

HARNESS SYMBOL : (F) (E) (R)

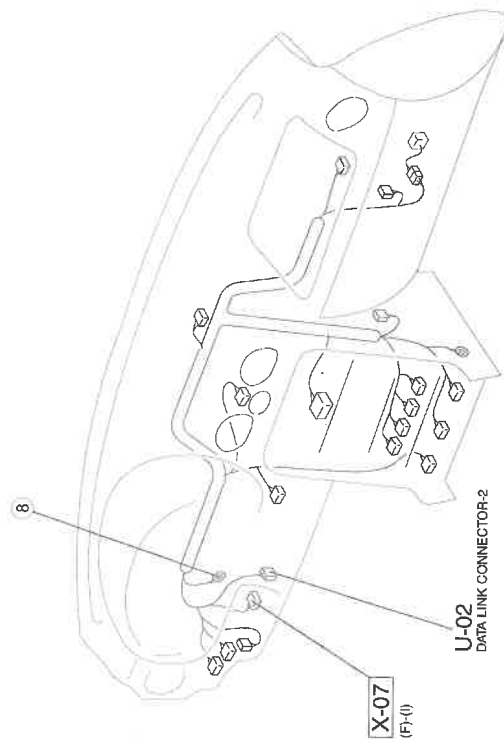
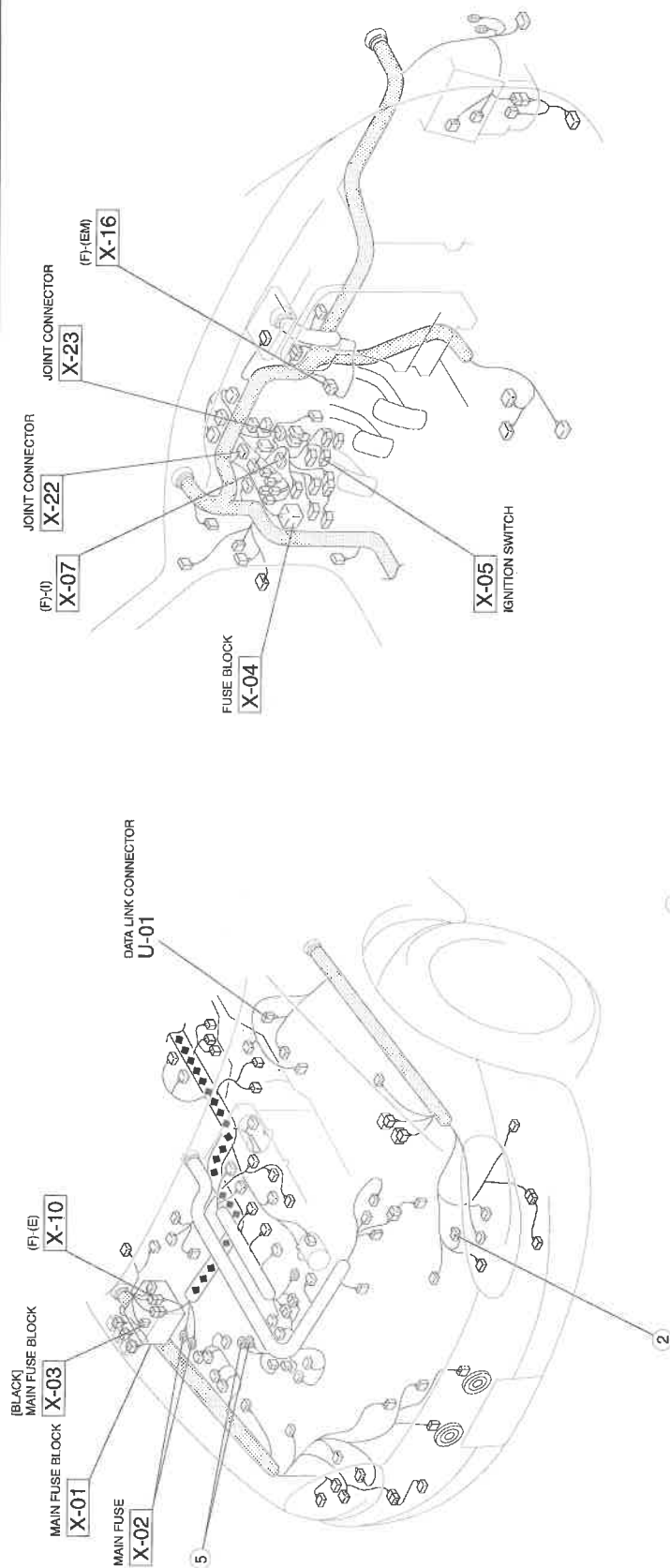

COMMON CONNECTOR LIST

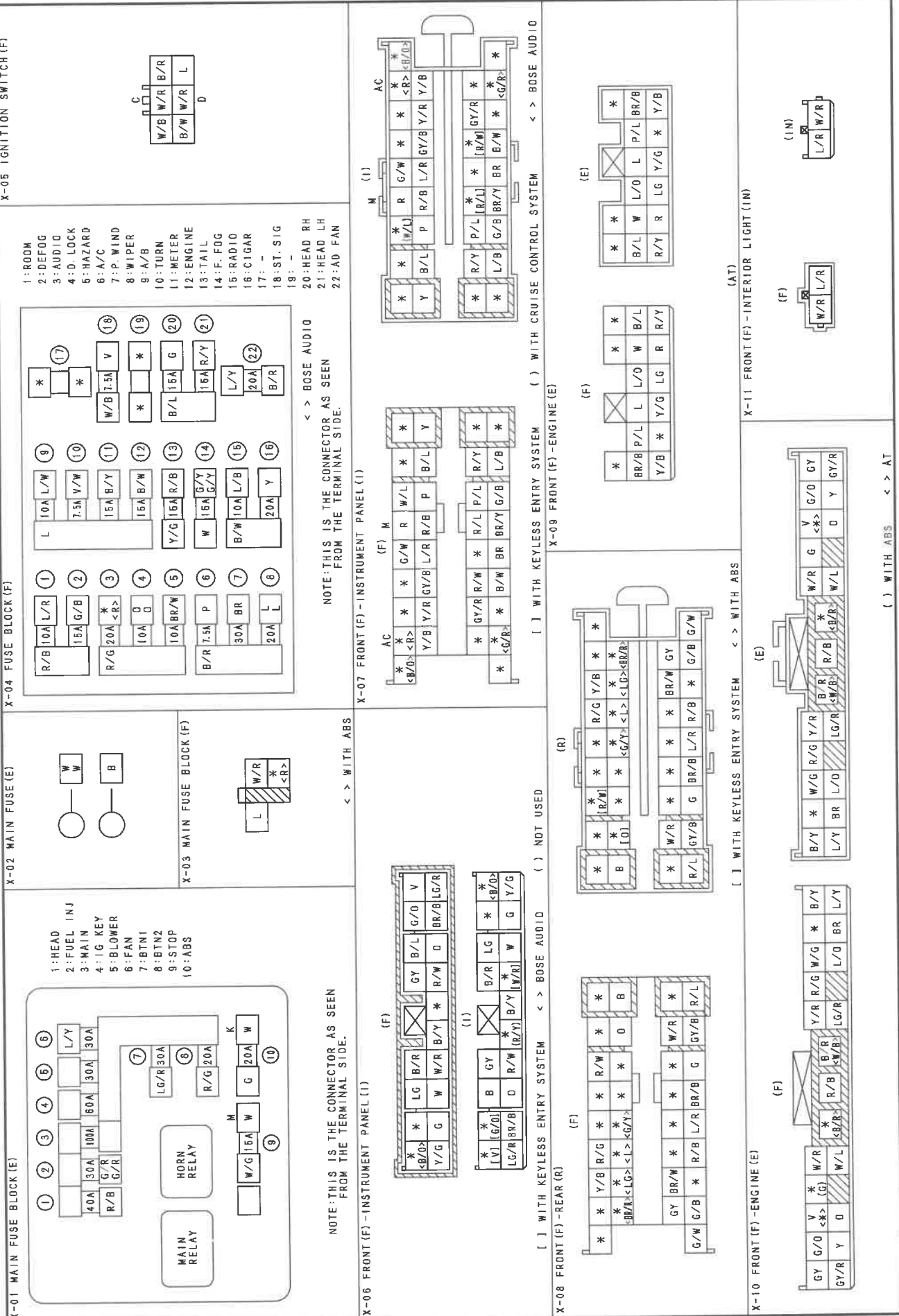

PARTS INDEX

A	
A/C RELAY	50
A/C SWITCH	50
ABS HYDRAULIC UNIT / CONTROL MODULE(ABS HU/CM).....	76
ABS WHEEL-SPEED SENSOR.....	76
AUDIO AMPLIFIER.....	66
AUDIO RELAY.....	66
AUDIO UNIT.....	64,66
B	
BACK-UP LIGHT.....	48
BACK-UP LIGHT SWITCH	48
BLOWER MOTOR.....	50
BLOWER RELAY	50
BRAKE FLUID LEVEL SENSOR	34
BRAKE LIGHT	48
BRAKE SWITCH.....	48,78
BUCKLE SWITCH.....	32
C	
CAMSHAFT POSITION SENSOR	20
CIGARETTE LIGHTER.....	58
CLUTCH SWITCH	22
COIL.....	84
CONDENSER	18,58
CONDENSER FAN	50
CONDENSER FAN RELAY	50
COOLING FAN MOTOR.....	28
COOLING FAN RELAY	28
CRANKSHAFT POSITION SENSOR	20
CRUISE ACTUATOR.....	78
CRUISE CONTROL MAIN SWITCH	78
CRUISE CONTROL MODULE.....	78
CRUISE CONTROL SWITCH.....	78
CRASH ZONE SENSOR	82
D	
DATA LINK CONNECTOR.....	86
DATA LINK CONNECTOR-2.....	86
DEFROSTER SWITCH.....	50
DOOR KEY CYLINDER SWITCH.....	72
DOOR LOCK ACTUATOR.....	72
DOOR LOCK CONTROL MODULE.....	72
DOOR LOCK SWITCH	72
DOOR SPEAKER	64,66
DOOR SWITCH	32
DRIVER-SIDE AIR BAG MODULE	82
DRIVER-SIDE PRE-TENSIONER SEAT BELT	82
DRL CONTROL MODULE	40
E	
EC-AT SOLENOID VALVE	52
EGR BOOST SENSOR.....	22
EGR BOOST SENSOR SOLENOID VALVE	24
EGR VALVE.....	20
ENGINE COOLANT TEMPERATURE SENSOR.....	22,32
EVAP SYSTEM LEAK DETECTION PUMP.....	24

F	
FAN SWITCH	50
FILAMENT.....	58
FLASHER CONTROL MODULE.....	46
FRONT FOG LIGHT.....	44
FRONT FOG LIGHT RELAY	44
FRONT FOG LIGHT SWITCH	44
FRONT SIDE MARKER LIGHT.....	42
FRONT TURN LIGHT	46
FUEL INJECTOR	20
FUEL PUMP RELAY	26
FUEL PUMP UNIT	26
FUSIBLE LINK	76
G	
GENERATOR.....	16
H	
HAZARD WARNING SWITCH	46
HEADLIGHT.....	38,40
HEADLIGHT RELAY	38,40
HEADLIGHT SWITCH.....	38,40
HEATED OXYGEN SENSOR.....	18
HIGH-MOUNT BRAKE LIGHT	48
HORN.....	48
HORN RELAY	48
HORN SWITCH.....	48
I	
IDLE AIR CONTROL VALVE	24
IGNITION COIL.....	18
ILLUMINATION	
AUDIO UNIT	56
CRUISE CONTROL MAIN SWITCH.....	56
FAN SWITCH.....	56
FRONT FOG LIGHT SWITCH.....	56
HAZARD WARNING SWITCH	56
INSTRUMENT CLUSTER	56
SHIFT-LOCK ACTUATOR	56
IMMOBILIZER UNIT.....	84
INPUT/TURBINE SPEED SENSOR	52
INSTRUMENT CLUSTER	30,32,34
INTAKE AIR TEMPERATURE SENSOR.....	22
INTERIOR LIGHT.....	60
K	
KEY INTERLOCK SOLENOID.....	54
KEY INTERLOCK UNIT	54
KEY REMINDER SWITCH.....	30
KNOCK SENSOR	24
KEYLESS CONTROL MODULE	62
L	
LICENSE PLATE LIGHT	42
M	
MAGNETIC CLUTCH.....	50
MAIN RELAY	18
MASS AIR FLOW SENSOR.....	20

PARTS INDEX

N	
NEUTRAL SWITCH	22
O	
O/D OFF SWITCH	52
OIL CONTROL VALVE	24
OIL PRESSURE SWITCH	32
OUTPUT SPEED SENSOR	52
P	
PANEL LIGHT CONTROL SWITCH	56
PARKING BRAKE SWITCH	34
PARKING LIGHT	42
PASSENGER AIR BAG DEACTIVATION SWITCH	82
PASSENGER AIR BAG DEACTIVATION SWITCH WARNING LIGHT	56
PASSENGER-SIDE AIR BAG MODULE	82
PASSENGER-SIDE PRE-TENSIONER SEAT BELT	82
PCM	18,20,22,24
POWER ANTENNA	68
POWER OUTSIDE MIRROR	74
POWER OUTSIDE MIRROR SWITCH	74
POWER STEERING PRESSURE SWITCH	18
POWER WINDOW REGULATOR	70
POWER WINDOW SWITCH	70
PURGE SOLENOID VALVE	24
R	
REAR TURN LIGHT	46
REAR WINDOW DEFROSTER RELAY	58
REAR WINDOW DEFROSTER SWITCH	58
REFRIGERANT PRESSURE SWITCH	50
RESISTOR	54
S	
SAS CONTROL MODULE	82
SHIFT-LOCK ACTUATOR	54
STARTER	16
STARTER INTERLOCK SWITCH	16
T	
TAILLIGHT	42
THERMOSWITCH	50
THROTTLE POSITION SENSOR	22
TNS RELAY	38,40
TRANSMISSION CONTROL MODULE	52
TRANSMISSION RANGE SWITCH	16,52
TRUNK COMPATRMET LIGHT	42
TRUNK COMPATRMET LIGHT RELAY	42
TRUNK COMPATRMET LIGHT SWITCH	42
TRUNK LID LOCK ACTUATOR	62
TRUNK LID OPENER RELAY	62
TURN SWITCH	46
TWEETER	64,66
V	
VEHICLE SPEEDOMETER SENSOR	30
VTCS SOLENOID VALVE	20
VTCS VACUUM SWITCH	24
W	
WINDSHIELD WASHER MOTOR	36
WINDSHIELD WIPER AND WASHER SWITCH	36
WINDSHIELD WIPER MOTOR	36

NOTES

NOTES

NOTES